

# BE AGRI EASE

AG & INDUSTRIAL

## EQUIPMENT CATALOG

2024

### HEAVY DUTY ROCK BUCKET

BE-DB060TA



PG. 101

### DELUXE HEAVY DUTY BOX BLADE

BE-BBR5ND



PG. 9

### TRENCHER

BE-TR450H



POWERED by  
**HONDA**

PG. 164

### 4400 LBS SKID STEER PALLET FORKS

BE-PF5048HBO500J

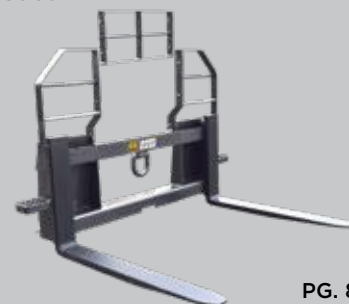

PG. 83

### 25 TON LOG SPLITTER

BE-LS25EH



POWERED by  
**HONDA**

PG. 153

### ROUND BACK ROTARY CUTTER

BE-RCR500G



MIX &  
MATCH!  
SAVE  
3%!

**INCLUDES SLIP CLUTCH PTO DRIVELINE!  
COMING SPRING 2024!**

PG. 18

### FORESTRY MULCHER

BE-FMC78



PG. 40

**BRABEREQ.COM**

WGSALES@BRABEREQ.COM

PHONE: 604-850-7770

FAX: 604-850-7774

TOLL FREE PHONE: 1-877-588-3311

TOLL FREE FAX: 1-800-665-7334



**NUMERICAL TABLE OF CONTENTS**

<b>6-7</b>	SUB COMPACT	<b>105-106</b>	TOW HITCHES & ACCESSORIES
<b>8-10</b>	BOX BLADES	<b>107-108</b>	POST HOLE DIGGERS
<b>11</b>	BOX SCRAPERS	<b>109</b>	PLOWS
<b>12-13</b>	LANDSCAPE RAKES	<b>110</b>	DISC HARROWS
<b>14-16</b>	REAR BLADES	<b>111-112</b>	CULTIVATORS
<b>17-19</b>	ROTARY CUTTERS	<b>113-114</b>	SUBSOILERS & MIDDLEBUSTERS
<b>20-24</b>	FINISH MOWERS	<b>115-116</b>	3 POINT HITCH BACKHOES
<b>25-29</b>	FLAIL MOWERS - FIXED	<b>117-119</b>	HARROWS
<b>30-32</b>	SHREDDERS	<b>120</b>	FERTILIZER SPREADERS
<b>33-34</b>	BOOM MOWERS	<b>121-122</b>	MANURE SPREADERS
<b>35</b>	VERGE MOWERS	<b>123-135</b>	PORTABLE SPRAYERS
<b>36-38</b>	FLAIL MOWERS - BOOM	<b>136-140</b>	MIST BLOWERS
<b>39-40</b>	HEDGE TRIMMERS	<b>141-143</b>	STUMP GRINDERS
<b>41-47</b>	ROTARY TEDDERS & RAKES	<b>144-150</b>	WOOD CHIPPERS
<b>48</b>	SICKLE BAR MOWERS	<b>151-158</b>	LOG SPLITTERS
<b>49</b>	DRUM MOWER	<b>159-165</b>	GAS POWERED TILLERS & MOWERS
<b>50-76</b>	ROTARY TILLERS	<b>166</b>	LEAF BLOWER
<b>77-78</b>	SNOW BLOWERS	<b>167</b>	SOIL CONDITIONERS & AERATORS
<b>79-80</b>	SNOW BLADES	<b>168</b>	BRUSH RAKES & POTATO LIFTERS
<b>81-89</b>	PALLET FORKS	<b>169</b>	CEMENT MIXERS & BOOM POLES
<b>89</b>	DEBRIS FORKS	<b>170-174</b>	DUMP CARTS
<b>90-92</b>	BALE SPEARS	<b>175</b>	DOLLIES
<b>93-103</b>	SKID STEER ATTACHMENTS	<b>176-177</b>	LAWN IMPLEMENTS
<b>104</b>	QUICK HITCHES	<b>178</b>	SHREDDERS





**ALPHABETICAL TABLE OF CONTENTS**

<b>115-116</b>	3 POINT HITCH BACKHOES	<b>121-122</b>	MANURE SPREADERS
<b>90-92</b>	BALE SPEARS	<b>136-140</b>	MIST BLOWERS
<b>33-34</b>	BOOM MOWERS	<b>81-89</b>	PALLET FORKS
<b>8-10</b>	BOX BLADES	<b>109</b>	PLOWS
<b>11</b>	BOX SCRAPERS	<b>123-135</b>	PORTABLE SPRAYERS
<b>168</b>	BRUSH RAKES & POTATO LIFTERS	<b>107-108</b>	POST HOLE DIGGERS
<b>169</b>	CEMENT MIXERS & BOOM POLES	<b>104</b>	QUICK HITCHES
<b>111-112</b>	CULTIVATORS	<b>14-16</b>	REAR BLADES
<b>89</b>	DEBRIS FORKS	<b>17-19</b>	ROTARY CUTTERS
<b>110</b>	DISC HARROWS	<b>41-47</b>	ROTARY TEDDERS & RAKES
<b>175</b>	DOLLIES	<b>50-76</b>	ROTARY TILLERS
<b>49</b>	DRUM MOWER	<b>30-32</b>	SHREDDERS
<b>170-174</b>	DUMP CARTS	<b>48</b>	SICKLE BAR MOWERS
<b>120</b>	FERTILIZER SPREADERS	<b>93-103</b>	SKID STEER ATTACHMENTS
<b>20-24</b>	FINISH MOWERS	<b>79-80</b>	SNOW BLADES
<b>36-38</b>	FLAIL MOWERS - BOOM	<b>77-78</b>	SNOW BLOWERS
<b>25-29</b>	FLAIL MOWERS - FIXED	<b>167</b>	SOIL CONDITIONERS & AERATORS
<b>159-165</b>	GAS POWERED TILLERS & MOWERS	<b>178</b>	SPREADERS
<b>117-119</b>	HARROWS	<b>141-143</b>	STUMP GRINDERS
<b>39-40</b>	HEDGE TRIMMERS	<b>6-7</b>	SUB COMPACT
<b>12-13</b>	LANDSCAPE RAKES	<b>113-114</b>	SUBSOILERS & MIDDLEBUSTERS
<b>176-177</b>	LAWN IMPLEMENTS	<b>105-106</b>	TOW HITCHES & ACCESSORIES
<b>166</b>	LEAF BLOWER	<b>35</b>	VERGE MOWERS
<b>151-158</b>	LOG SPLITTERS	<b>144-150</b>	WOOD CHIPPERS

# 48" SUB COMPACT BOX BLADE

BE-BBC48N

**MIX &  
MATCH  
& SAVE!**

PART #	BE-BBC48N	BE-BBC54N	BE-BBC60N
HITCH	CAT 1	CAT 1	CAT 1
CAPACITY	7 FT <sup>3</sup>	7 FT <sup>3</sup>	7 FT <sup>3</sup>
WEIGHT	277 LBS	288 LBS	300 LBS
WORKING WIDTH	48"	54"	60"
NUMBER OF SHANKS	4	4	5
HP RATING	UP TO 25 HP	UP TO 25 HP	UP TO 25 HP



# 48" SUB COMPACT LANDSCAPE RAKE

BE-LRC48N



PART #	BE-LRC48N
HITCH	CAT 1
WEIGHT	98 LBS
WORKING WIDTH	48"
RAKE HEIGHT	12"
NUMBER OF TEETH	26
HP RATING	15 - 25 HP

# 48" SUB COMPACT REAR BLADE

BE-RBC48N



PART #	BE-RBC48N
HITCH	CAT 1
WEIGHT	128 LBS
WORKING WIDTH	48"
BLADE OFFSET	10" LEFT OR RIGHT
HP RATING	17 - 25 HP

# 36" LIGHT DUTY/SUB COMPACT PALLET FORKS

PART #	BE-PFLD36EBO
CAPACITY	1100 LBS
WEIGHT	170 LBS
FORK LENGTH	36"
CARRIAGE MOUNT	SKID STEER



## REPLACEMENT PARTS

FORK	PFT36ELD
------	----------

**SUB COMPACT**

**SUB  
COMPACT  
ROTARY  
TILLER**

33"



PART #	BE-TL85
WEIGHT	310 LBS
TILLING WIDTH	33"
HP RATING	12 - 40 HP
TILLAGE DEPTH	2 - 6"
BLADES	16

CAT 1, 3 POINT HITCH

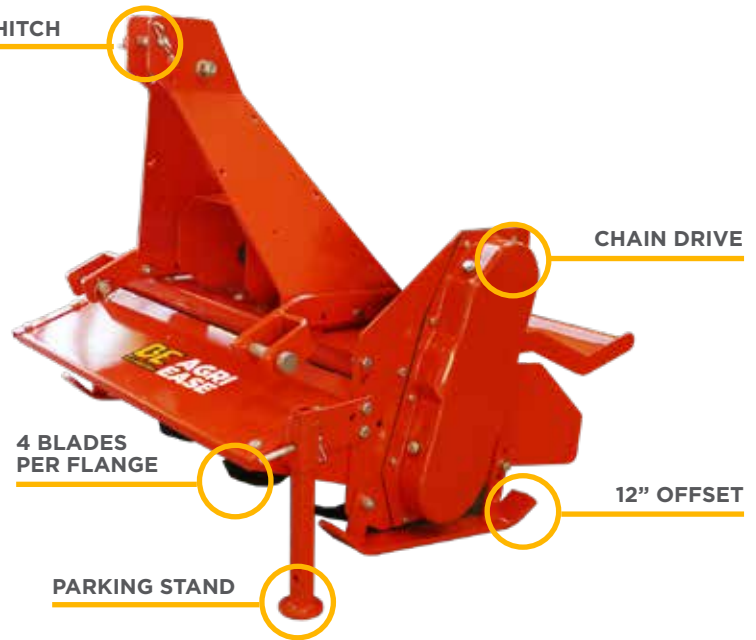

**COMPACT  
TRACTOR  
POST  
HOLE  
DIGGER**

40"

**BUY  
MULTIPLE  
& SAVE  
3%!**



PART #	BE-PHDLG
WEIGHT	135 LBS
DRILLING DEPTH	40"

SWIVEL TOP LINK

SHORTER BOOM  
FOR EASIER LIFTING  
WITH SUB 30 HP TRACTOR



HEAVY DUTY  
OIL-FILLED 40 HP GEARBOX



SEE PAGE 92 FOR AUGERS

# BOX BLADE

48", 54", 60", 66", 72", 84"

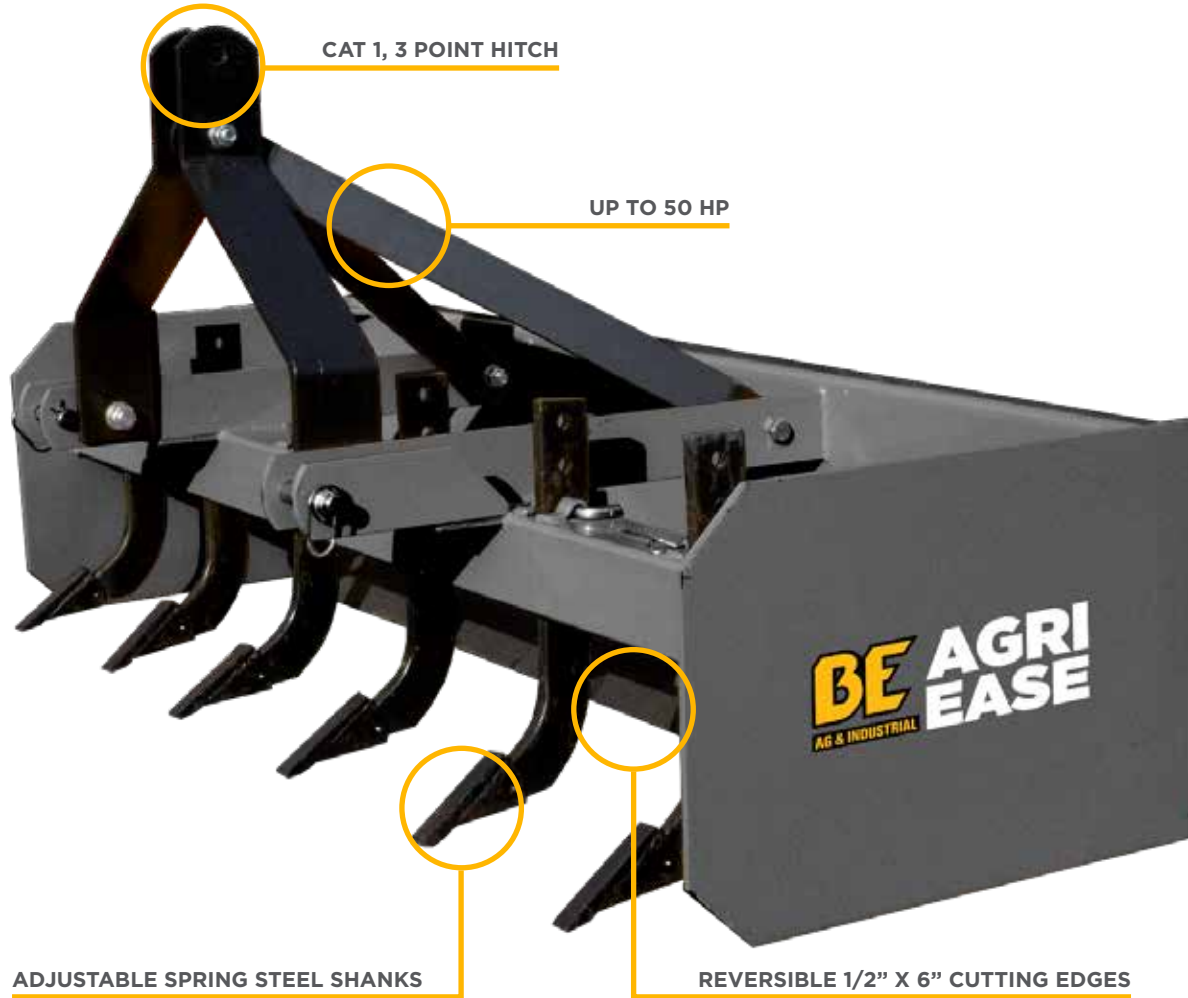

CAT 1, 3 POINT HITCH

UP TO 50 HP

ADJUSTABLE SPRING STEEL SHANKS

REVERSIBLE 1/2" X 6" CUTTING EDGES

PART #	BE-BBR4N	BE-BBR45N	BE-BBR5N	BE-BBR55N	BE-BBR6N	BE-BBR7N
WEIGHT	368 LBS	398 LBS	446 LBS	475 LBS	496 LBS	584 LBS
WIDTH	48"	54"	60"	66"	72"	84"
HP RATING	UP TO 50 HP	UP TO 50 HP	UP TO 50 HP	UP TO 50 HP	UP TO 50 HP	UP TO 50 HP
NO. OF SHANKS	4	4	5	5	6	7
MOLDBOARD HEIGHT	17"	17"	17"	17"	17"	17"
SIDE PANEL THICKNESS	3/8"	3/8"	3/8"	3/8"	3/8"	3/8"

## REPLACEMENT WEAR PARTS

CUTTING EDGE	CE4S	484502G	CE5S	485502G	CE6S	CE7S
SHANK	BB2G	BB2G	BB2G	BB2G	BB2G	BB2G
SHANK TIP	BBSTHDG	BBSTHDG	BBSTHDG	BBSTHDG	BBSTHDG	BBSTHDG

**DELUXE  
HEAVY DUTY  
BOX BLADE**

48", 54", 60", 66", 72"



\*PRODUCT MAY NOT BE EXACTLY AS SHOWN

PART #	BE-BBR4ND	BE-BBR45ND	BE-BBR5ND	BE-BBR55ND	BE-BBR6ND
WEIGHT	414 LBS	465 LBS	502 LBS	530 LBS	558 LBS
WIDTH	48"	54"	60"	66"	72"
HP RATING	UP TO 50 HP	UP TO 50 HP	UP TO 50 HP	UP TO 50 HP	UP TO 50 HP
NO. OF SHANKS	4	4	5	5	6
MOLDBOARD HEIGHT	17"	17"	17"	17"	17"
SIDE PANEL THICKNESS	3/8"	3/8"	3/8"	3/8"	3/8"

**REPLACEMENT WEAR PARTS**

SHANK	BB2G	BB2G	BB2G	BB2G	BB2G
SHANK TIP	BBSTHDG	BBSTHDG	BBSTHDG	BBSTHDG	BBSTHDG

**EXTRA  
HEAVY DUTY  
BOX BLADE**

84," 96"



\*PRODUCT MAY NOT BE EXACTLY AS SHOWN

PART #	BE-BBR7ND	BE-BBR8ND
WEIGHT	657 LBS	690 LBS
WIDTH	84"	96"
HP RATING	UP TO 50 HP	UP TO 50 HP
NO. OF SHANKS	7	8
MOLDBOARD HEIGHT	17"	17"
SIDE PANEL THICKNESS	1/2"	1/2"

**REPLACEMENT WEAR PARTS**

SHANK	BB2G	BB2G
SHANK TIP	BBSTHDG	BBSTHDG



# BOX GRADER SCRAPER

54", 60", 72", 84", 96"



TOP VIEW

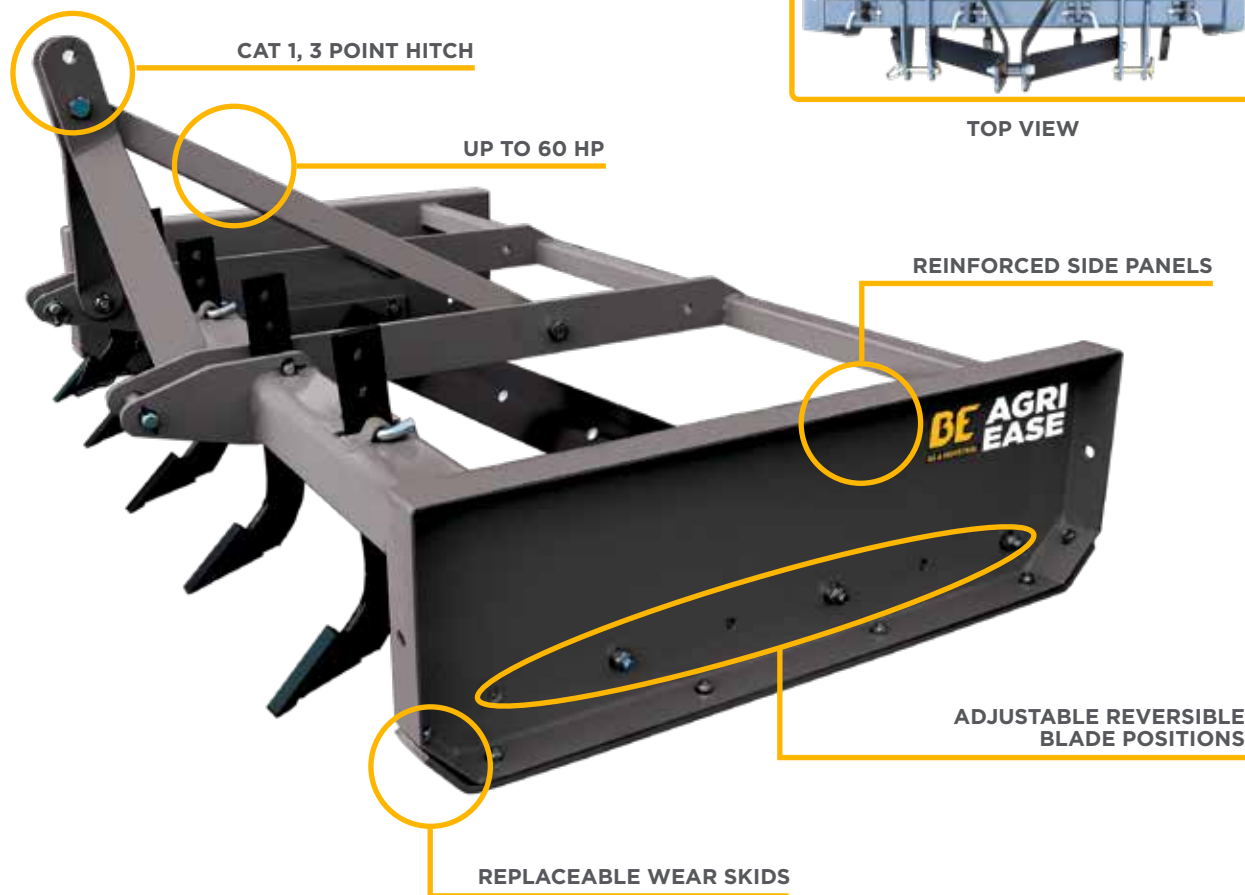

PART #	BE-GS045N	BE-GS05N	BE-GS06N	BE-GS07N	BE-GS08N
WEIGHT	465 LBS	515 LBS	605 LBS	690 LBS	780 LBS
WIDTH	54"	60"	72"	84"	96"
HP RATING	15 - 45 HP	20 - 45 HP	25 - 50 HP	25 - 60 HP	35 - 60 HP
MOUNT	3 POINT	3 POINT	3 POINT	3 POINT	3 POINT
NO. SHANKS	4	4	5	6	7

## REPLACEMENT WEAR PARTS

CUTTING EDGE	GS4.45G	GS4.5G	GS4.6G	GS4.7G	GS4.8G
SHANK	BB2G	BB2G	BB2G	BB2G	BB2G
SHANK TIP	BBSTHDG	BBSTHDG	BBSTHDG	BBSTHDG	BBSTHDG

# 3 POINT LANDSCAPE RAKE

60", 72", 84"

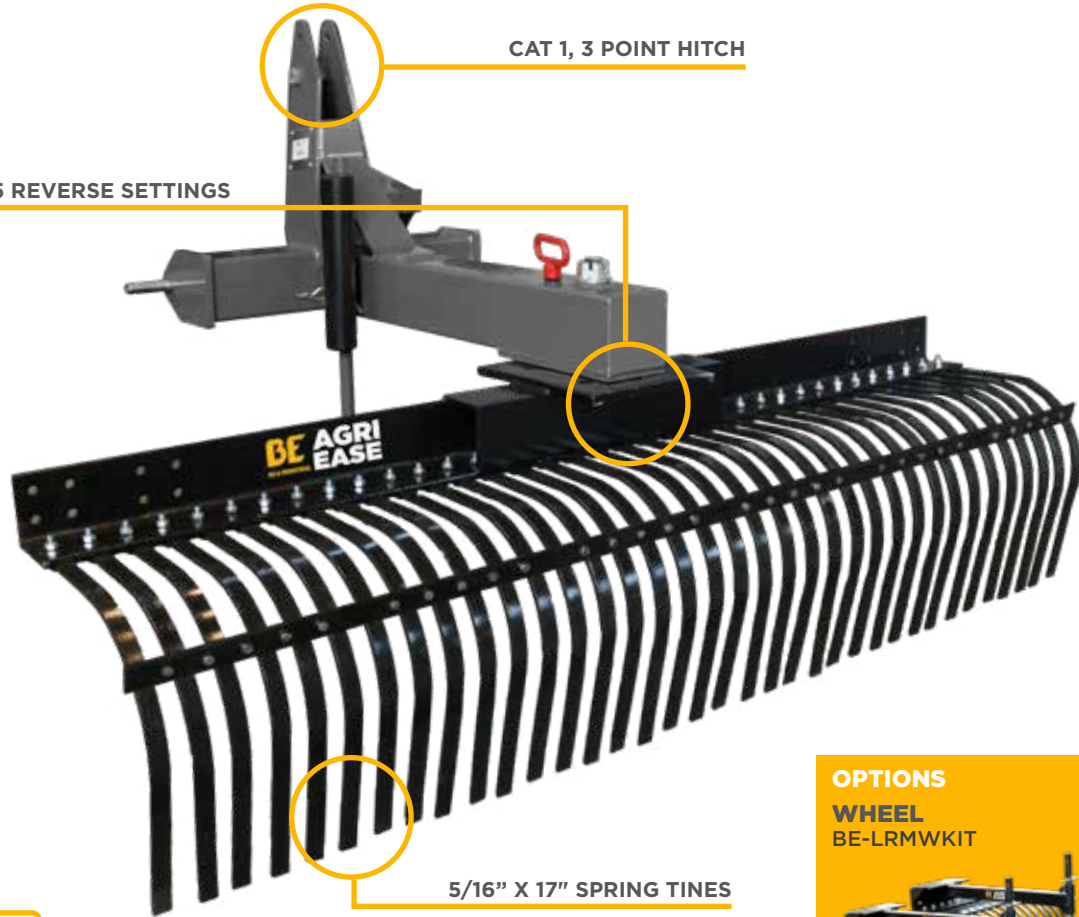

**INCLUDES  
TINE  
SECURING  
BAR**



PART #	BE-LRM5G	BE-LRM6G	BE-LRM7G
WEIGHT	255 LBS	280 LBS	310 LBS
WORKING WIDTH	60"	72"	84"
HP RATING	50 HP	50 HP	50 HP

**REPLACEMENT WEAR PARTS**

REPLACEMENT TINES	RRTINEG	RRTINEG	RRTINEG
-------------------	---------	---------	---------

**OPTIONS**

WHEEL	BE-LRMWKIT	BE-LRMWKIT	BE-LRMWKIT
-------	------------	------------	------------



# 3 POINT LANDSCAPE RAKE

72", 84"

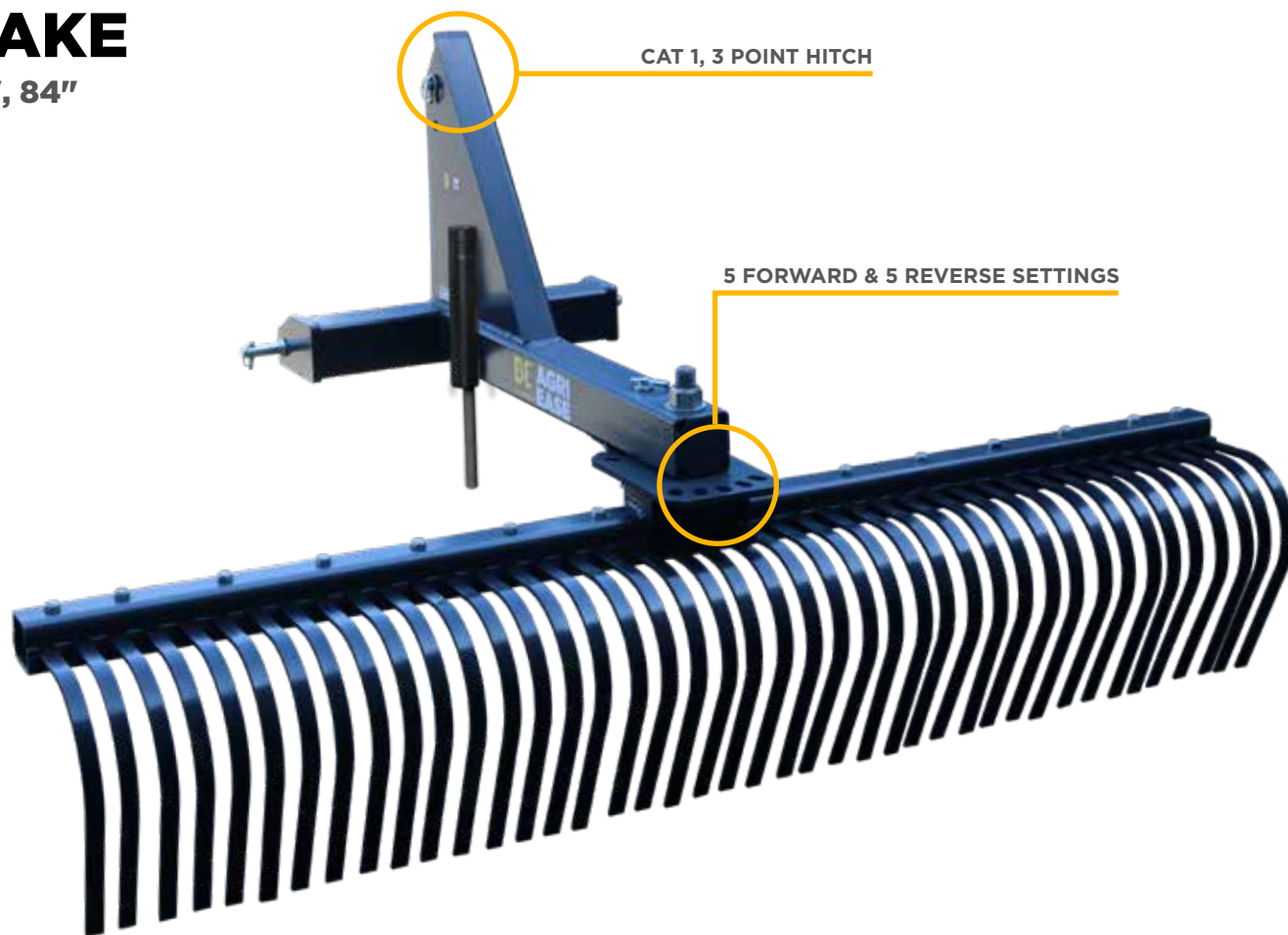

PART #	BE-LR6FK	BE-LR7FK
WEIGHT	238 LBS	260 LBS
WORKING WIDTH	72"	84"
HP RATING	25 - 40 HP	30 - 45 HP
TINE SIZE	1" X 0.3"	1" X 0.3"
TINE SPACING	1"	1"
TINE PER FEET	6	6
TINE MATERIAL	SPRING STEEL	SPRING STEEL

**STANDARD  
DUTY  
REAR  
BLADE**

48", 54", 60", 72", 84"

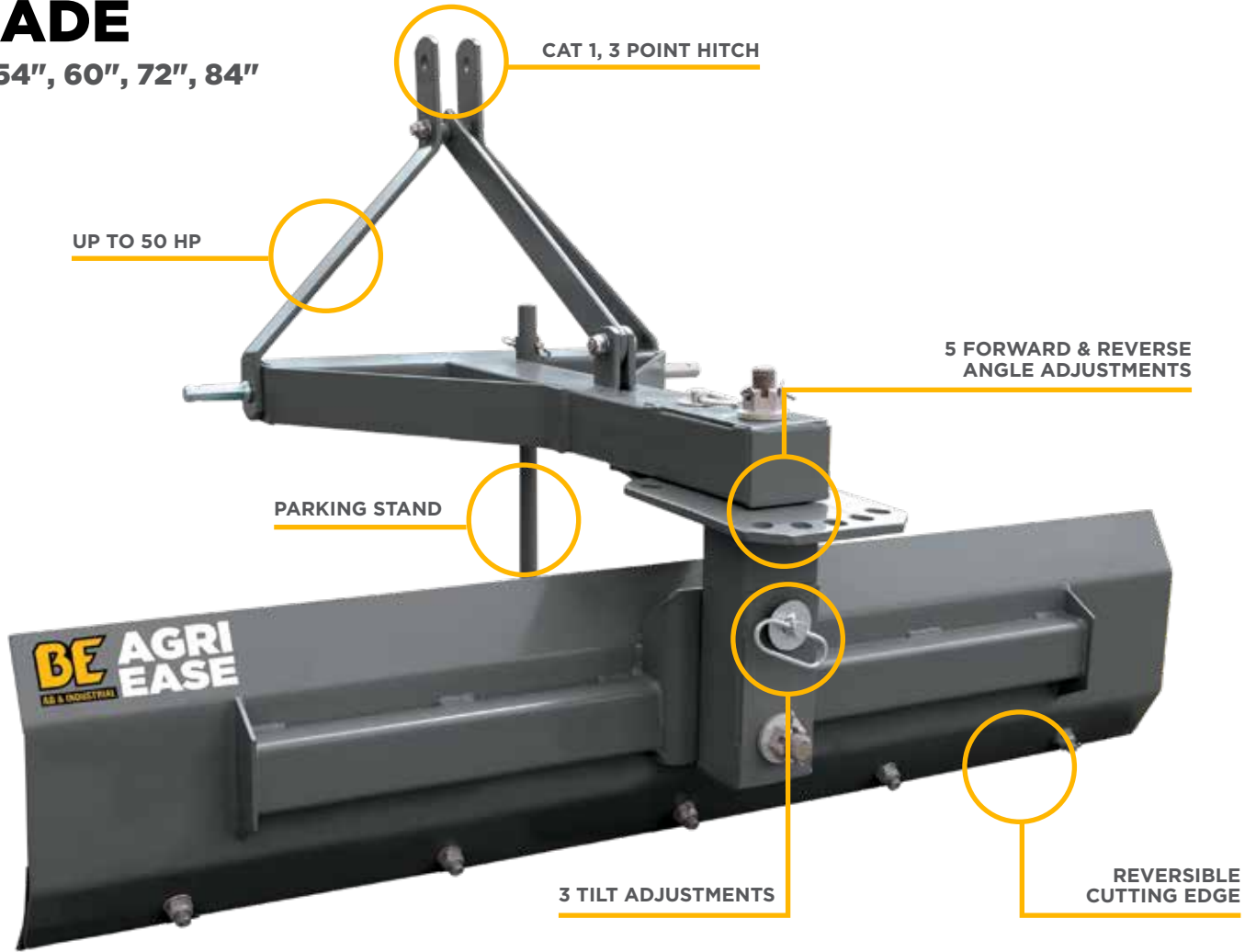

PART #	BE-RBR4N	BE-RBR45G	BE-RBR5N	BE-RBR6N	BE-RBR7N
WEIGHT	170 LBS	188 LBS	205 LBS	230 LBS	255 LBS
WIDTH	48"	54"	60"	72"	84"
HP RATING	20 - 30 HP	20 - 30 HP	20 - 30 HP	20 - 30 HP	20 - 30 HP
MOLDBOARD CUTTING EDGE	6"	6"	6"	6"	6"
MOLDBOARD HEIGHT	14-1/2"	14-1/2"	14-1/2"	14-1/2"	14-1/2"
MOLDBOARD THICKNESS	3/16"	3/16"	3/16"	3/16"	3/16"

**REPLACEMENT WEAR PARTS**

CUTTING EDGE	CE4L	CE45L	CE5L	CE6L	CE7L
--------------	------	-------	------	------	------

# HEAVY DUTY REAR BLADE

72", 84", 96"

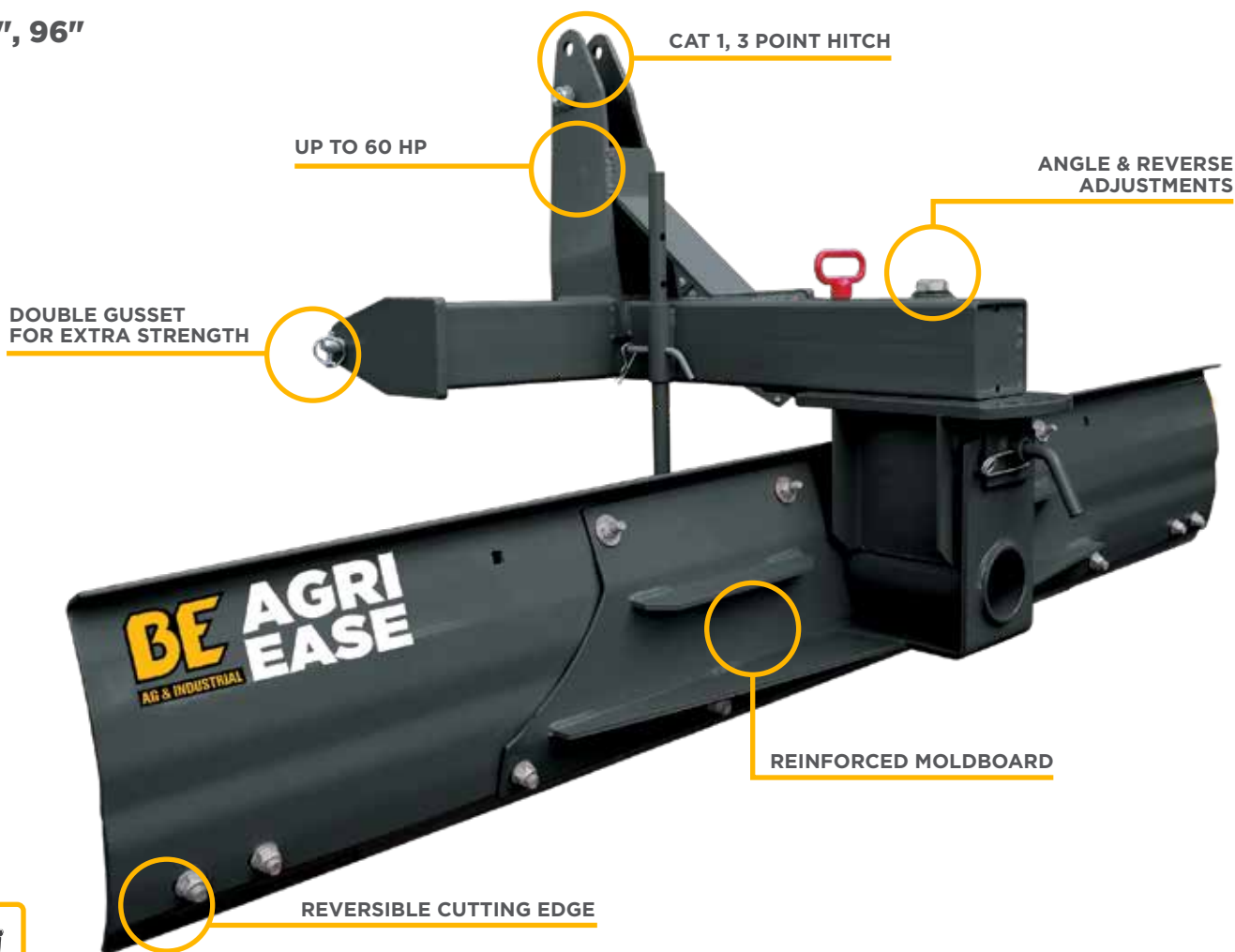

PART #	BE-RB206HD	BE-RB207HD	BE-RB208HD
WEIGHT	330 LBS	350 LBS	370 LBS
WIDTH	72"	84"	96"
HITCH	CAT 1	CAT 1	CAT 1
HP RATING	40 - 60 HP	40 - 60 HP	40 - 60 HP
MOLDBOARD CUTTING EDGE	6"	6"	6"
MOLDBOARD HEIGHT	14-1/2"	14-1/2"	14-1/2"
MOLDBOARD THICKNESS	1/4"	1/4"	1/4"

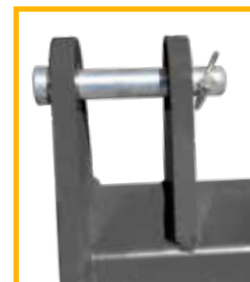

**DOUBLE GUSSET LIFT ARM CONNECTION FOR ADDED STRENGTH**

## REPLACEMENT WEAR PARTS

CUTTING EDGE	CE6H	CE7H	CE8H
--------------	------	------	------

# EXTRA HEAVY DUTY REAR BLADE

WITH HYDRAULIC ANGLE  
96", 108"

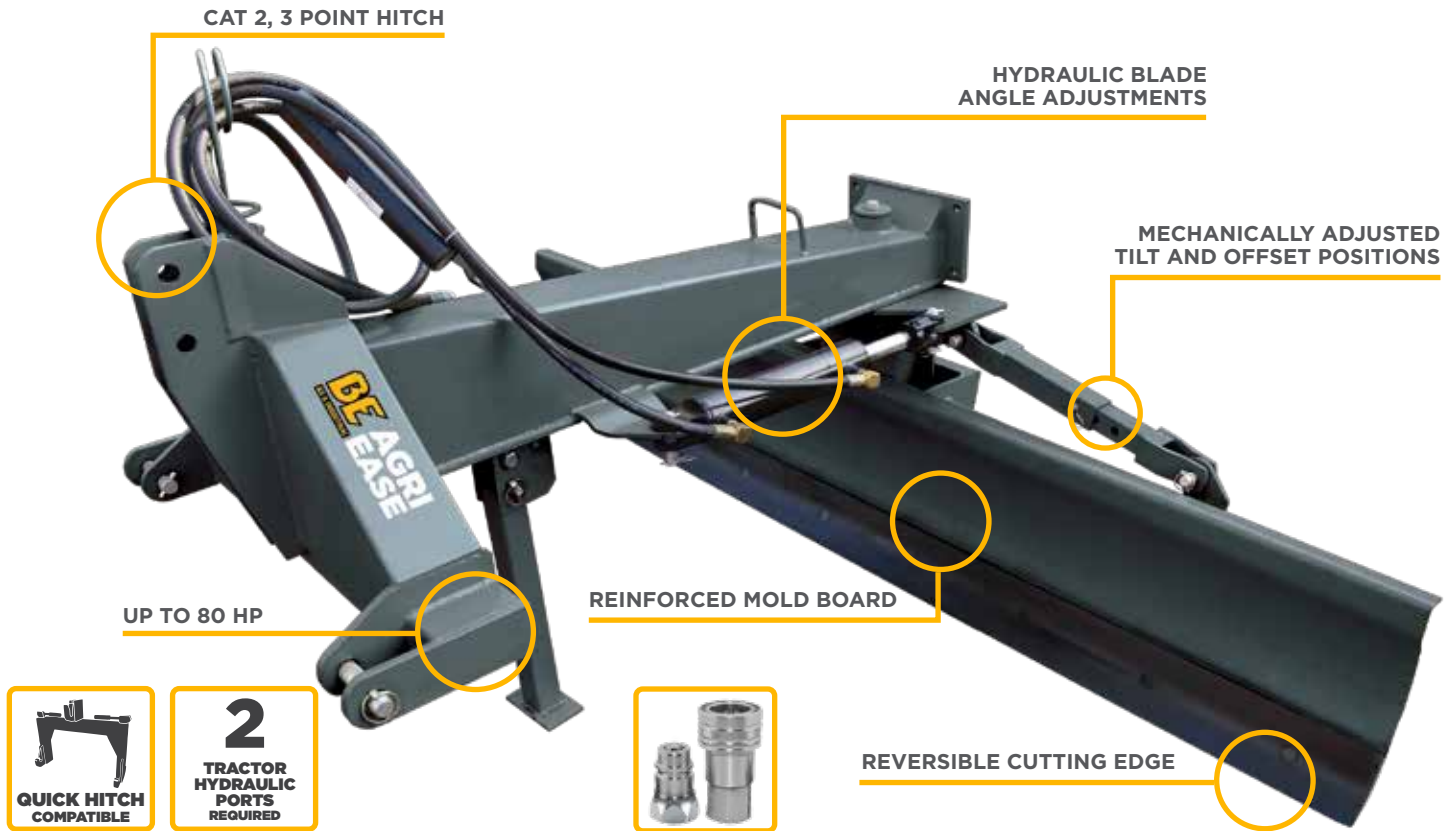

**2**  
TRACTOR  
HYDRAULIC  
PORTS  
REQUIRED



PART #	BE-RB408HDG	BE-RB409HDG
WEIGHT	970 LBS	1060 LBS
WIDTH	86"	108"
HP RATING	UP TO 80 HP	UP TO 80 HP
MOLDBOARD HEIGHT	18"	18"
MOLDBOARD THICKNESS	5/16"	5/16"
CUTTING EDGE	6"	6"
HYDRAULIC PORTS	2	2



**REPLACEMENT WEAR PARTS**

CUTTING EDGE	CE8HYD	CE9HYD
--------------	--------	--------

**OPTIONS**

PART #	RBHYDSHOE-SET	BE-RB408TILTCYL	BE-RB400OFFSETKIT
DESCRIPTION	SKID SHOES	TILT CYLINDER	OFFSET CYLINDER

**ROTARY CUTTERS**

**STANDARD DUTY ROTARY CUTTER**

40", 48", 54", 60", 66", 72"



PART #	BE-RC40-2G	BE-RC400G	BE-RC450G	BE-RC500G	BE-RC550G	BE-RC600G
WEIGHT	400 LBS	482 LBS	545 LBS	605 LBS	665 LBS	725 LBS
DECK WIDTH	40"	48"	54"	60"	66"	72"
CUTTING HEIGHT	1" - 8"	1" - 8"	1" - 8"	1" - 8"	1" - 8"	1" - 8"
PTO	SHEAR PIN	SHEAR PIN	SHEAR PIN	SHEAR PIN	SHEAR PIN	SHEAR PIN
BLADES	2	2	2	2	2	2
HP RATING	UP TO 50 HP	UP TO 50 HP	UP TO 50 HP	UP TO 50 HP	UP TO 50 HP	UP TO 50 HP
TOP DECK THICKNESS	3.5 MM	3.5 MM	3.5 MM	3.5 MM	3.5 MM	4 MM
SIDE DECK THICKNESS	3.75 MM	3.75 MM	3.75 MM	3.75 MM	3.75 MM	3.75 MM

**REPLACEMENT WEAR PARTS**

BLADE	55.000.215G	55.000.402G	55.000.450G	55.000.502G	55.000.550G	55.000.602G
BOLT KIT	55.000.055G	55.000.055G	55.000.055G	55.000.055G	55.000.055G	55.000.055G
PTO	69.888.049	69.888.049	69.888.049	69.888.049	69.888.049	69.888.049
SHEAR PIN KIT (5 PCS)	67.000.005	67.000.005	67.000.005	67.000.005	67.000.005	67.000.005



**ROUND BACK ROTARY CUTTER**

42", 48", 60", 72"

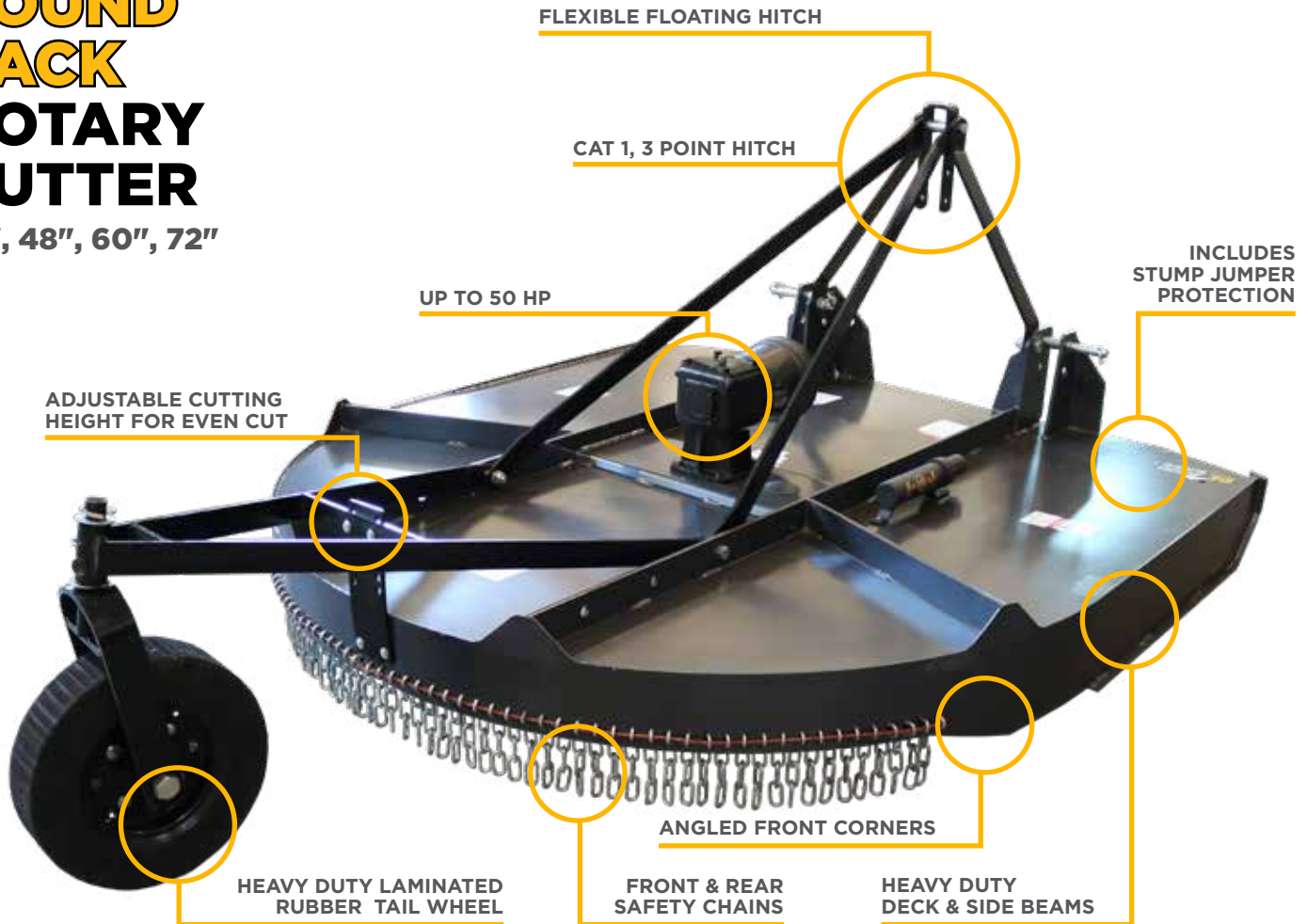

**INCLUDES SLIP CLUTCH PTO DRIVELINE!  
COMING SPRING 2024!**



PART #	BE-RCR350G	BE-RCR400G	BE-RCR500G	BE-RCR600G
WEIGHT	450 LBS	490 LBS	540 LBS	640 LBS
DECK WIDTH	42"	48"	60"	72"
HP RATING	20 - 50 HP	20 - 50 HP	20 - 50 HP	20 - 50 HP
PTO	SHEAR PIN	SHEAR PIN	SHEAR PIN	SHEAR PIN
BLADES	2	2	2	2
TOP DECK THICKNESS	3.5 MM	3.5 MM	3.5 MM	3.5 MM
SIDE DECK THICKNESS	3 MM	3 MM	3 MM	3 MM

**REPLACEMENT WEAR PARTS**

BLADE	55.000.215G	55.000.402G	55.000.502G	55.000.602G
BOLT KIT	55.000.055G	55.000.055G	55.000.055G	55.000.055G
PTO	69.888.049	69.888.049	69.888.049	69.888.049
SHEAR PIN KIT (5 PCS)	67.000.005	67.000.005	67.000.005	67.000.005

# ROUND BACK HEAVY DUTY ROTARY CUTTER

70 HP GEARBOX WITH SLIP CLUTCH PTO  
60", 72", 84"

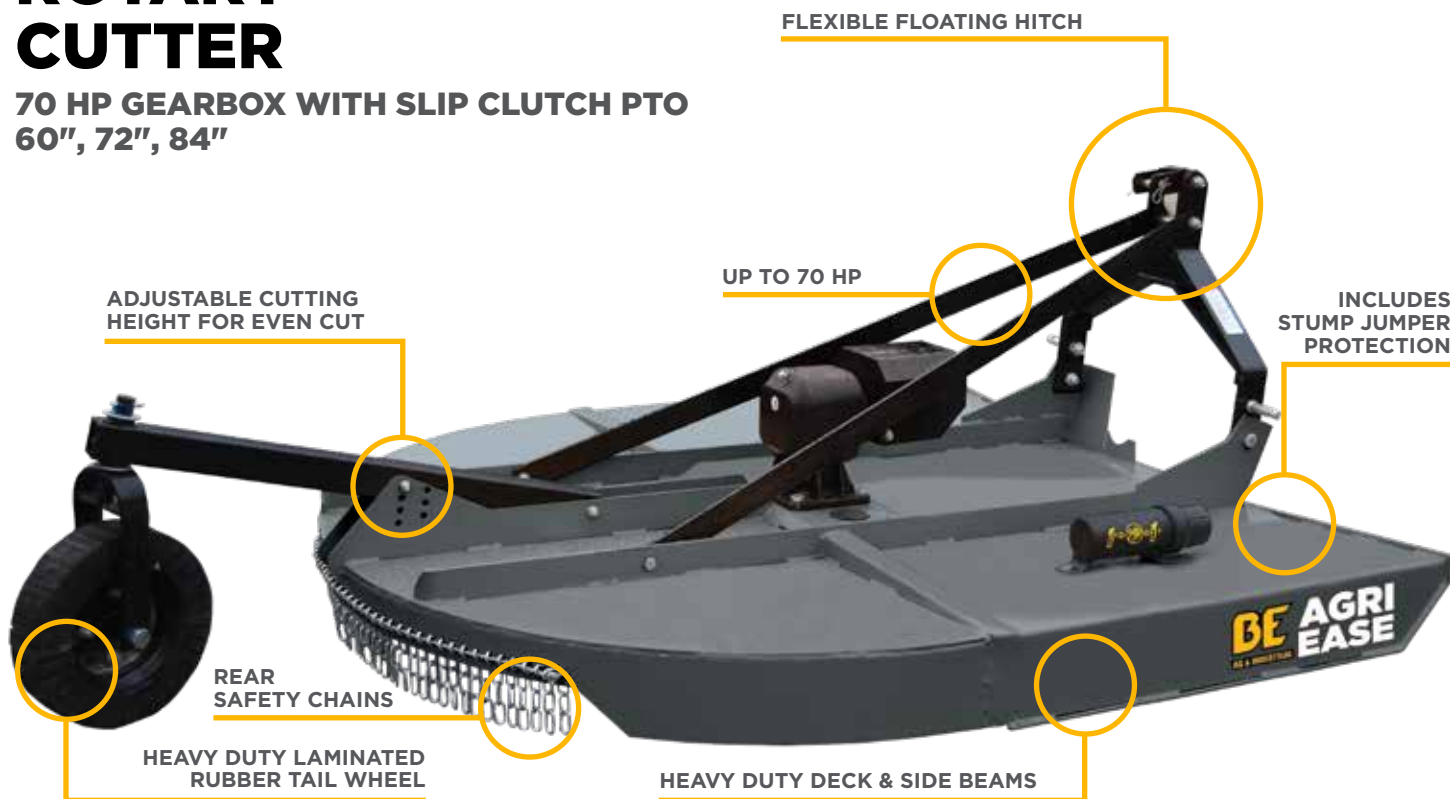

PART #	BE-RC5HDG	BE-RC6HDG	BE-RC7HDG
WEIGHT	700 LBS	840 LBS	1365 LBS
HITCH	CAT 1 QUICK HITCH COMPATIBLE	CAT 1 QUICK HITCH COMPATIBLE	CAT 2
DECK WIDTH	60"	72"	84"
PTO	SLIP CLUTCH	SLIP CLUTCH	SLIP CLUTCH
BLADES	2	2	2
HP RATING	UP TO 70 HP	UP TO 70 HP	UP TO 70 HP
TOP DECK THICKNESS	3.5 MM	4 MM	5 MM
SIDE DECK THICKNESS	3.5 MM	4 MM	4 MM

## REPLACEMENT WEAR PARTS

BLADE	55.000.502G	55.000.602G	55.000.702G
BOLT KIT	55.000.055G	55.000.055G	55.000.055G
PTO	69.777.039	69.888.602	69.888.602
CLUTCH DISC	247000061	247000061	247000061

# STANDARD DUTY REAR DISCHARGE FINISH MOWER

48", 60", 72"



HEIGHT ADJUSTABLE  
SOLID NO FLAT WHEELS

SINGLE PIECE FORMED DECK

GREASABLE  
WHEEL BEARINGS

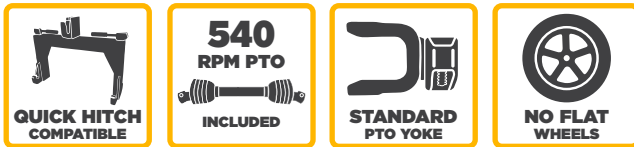

PART #	BE-FM48RDG	BE-FM60RDG	BE-FM72RDG
WEIGHT	310 LBS	360 LBS	460 LBS
WIDTH	48"	60"	72"
HP RATING	15 HP	20 HP	30 HP
PTO	540	540	540
BLADES	3	3	3
WHEEL SIZE	9-3/4" X 3"	9-3/4" X 3"	9-3/4" X 3"
MIN CUTTING HEIGHT	1"	1-5/16"	1-5/16"
MAX CUTTING HEIGHT	4"	4-1/2"	4-1/2"

## REPLACEMENT WEAR PARTS

BLADE	FM3.4	FM3.5	FM3.6
BELT	47.171.372	47.171.575	47.171.880
PTO	69.885.004	69.885.004	69.885.004



# HEAVY DUTY REAR DISCHARGE FINISH MOWER

48", 60", 72"

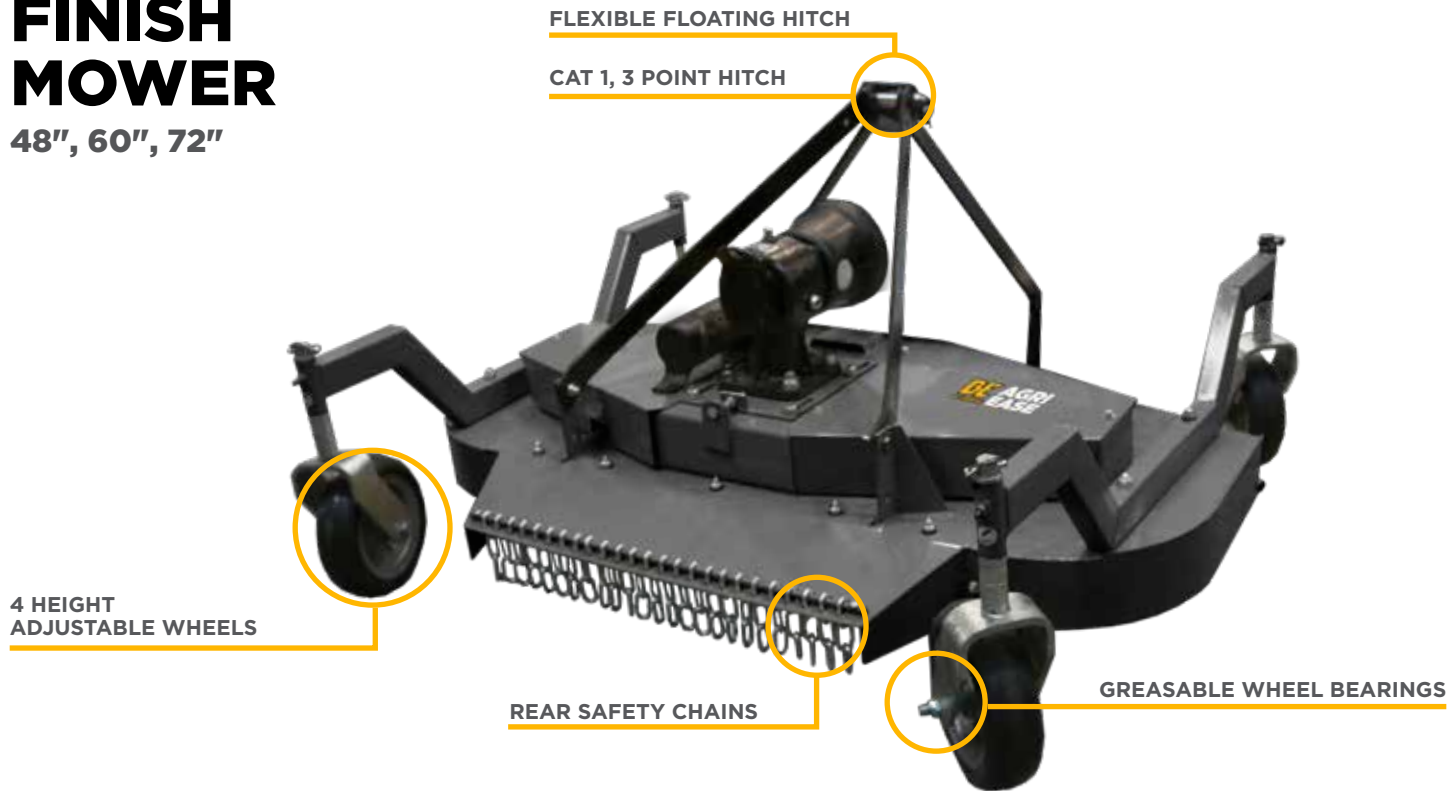

PART #	BE-FM48RDGS	BE-FM60RDGS	BE-FM72RDGS
WEIGHT	355 LBS	410 LBS	520 LBS
WIDTH	48"	60"	72"
HP RATING	15 HP	20 HP	30 HP
PTO	540	540	540
BLADES	3	3	3
WHEEL SIZE	9-3/4" X 3"	9-3/4" X 3"	9-3/4" X 3"
MIN CUTTING HEIGHT	1-3/4"	1-3/4"	1-3/4"
MAX CUTTING HEIGHT	5"	5"	5"

## REPLACEMENT WEAR PARTS

BLADE	340441	340541	340641
V BELT	47.171.372	47.171.575	47.171.880
PTO	69.885.004	69.885.004	69.885.004

# STANDARD DUTY FINISH MOWER

84", 96"

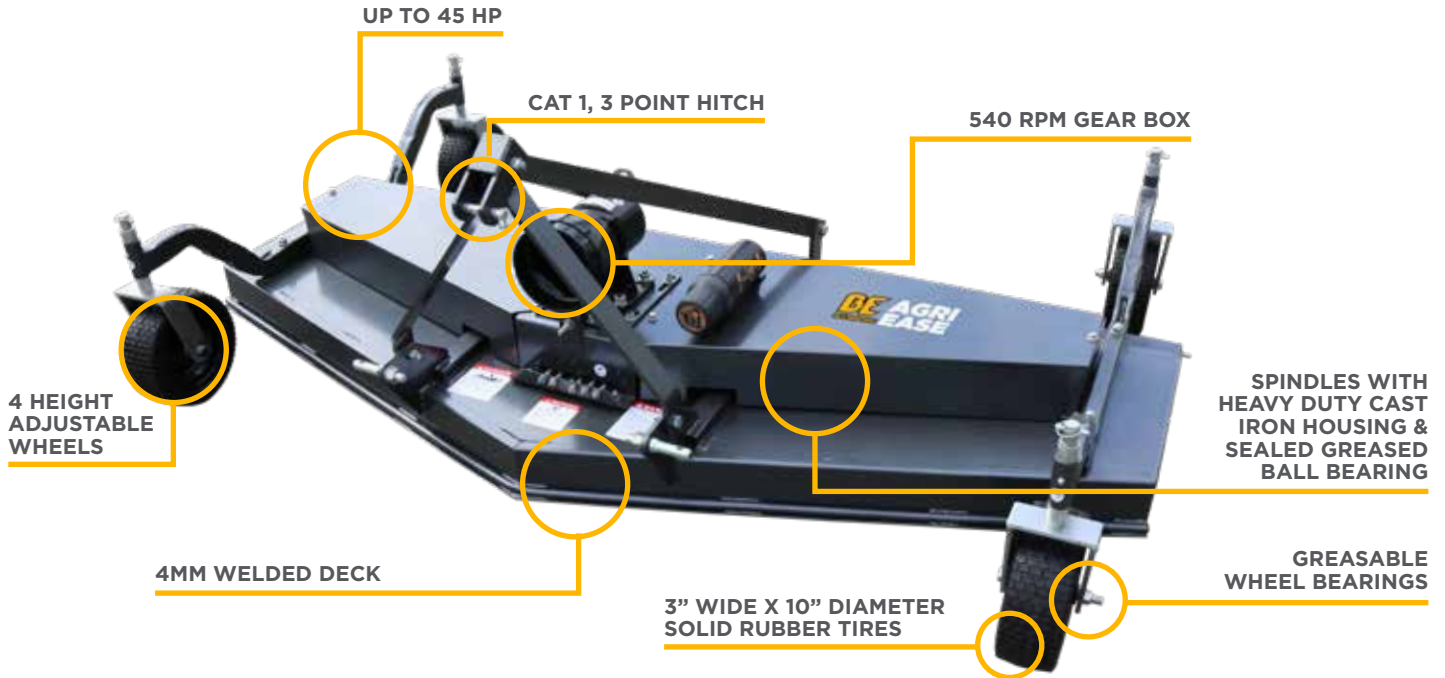

\*PRODUCT MAY NOT BE EXACTLY AS SHOWN

PART #	BE-FM84RDG	BE-FM96RDHDG
WEIGHT	660 LBS	778 LBS
WIDTH	84"	96"
HP RATING	45 HP	45 HP
CATEGORY	1	1
BLADES	3	5
WHEEL SIZE	11" X 3-3/4"	11" X 3-3/4"
MIN CUTTING HEIGHT	1"	1"
MAX CUTTING HEIGHT	4"	4"

## REPLACEMENT WEAR PARTS

BLADE	FM4.96HDG	FM4HDG
V BELT	FM71.B914 FM72.B2591	020745

# HEAVY DUTY DELUXE FINISH MOWER

84"

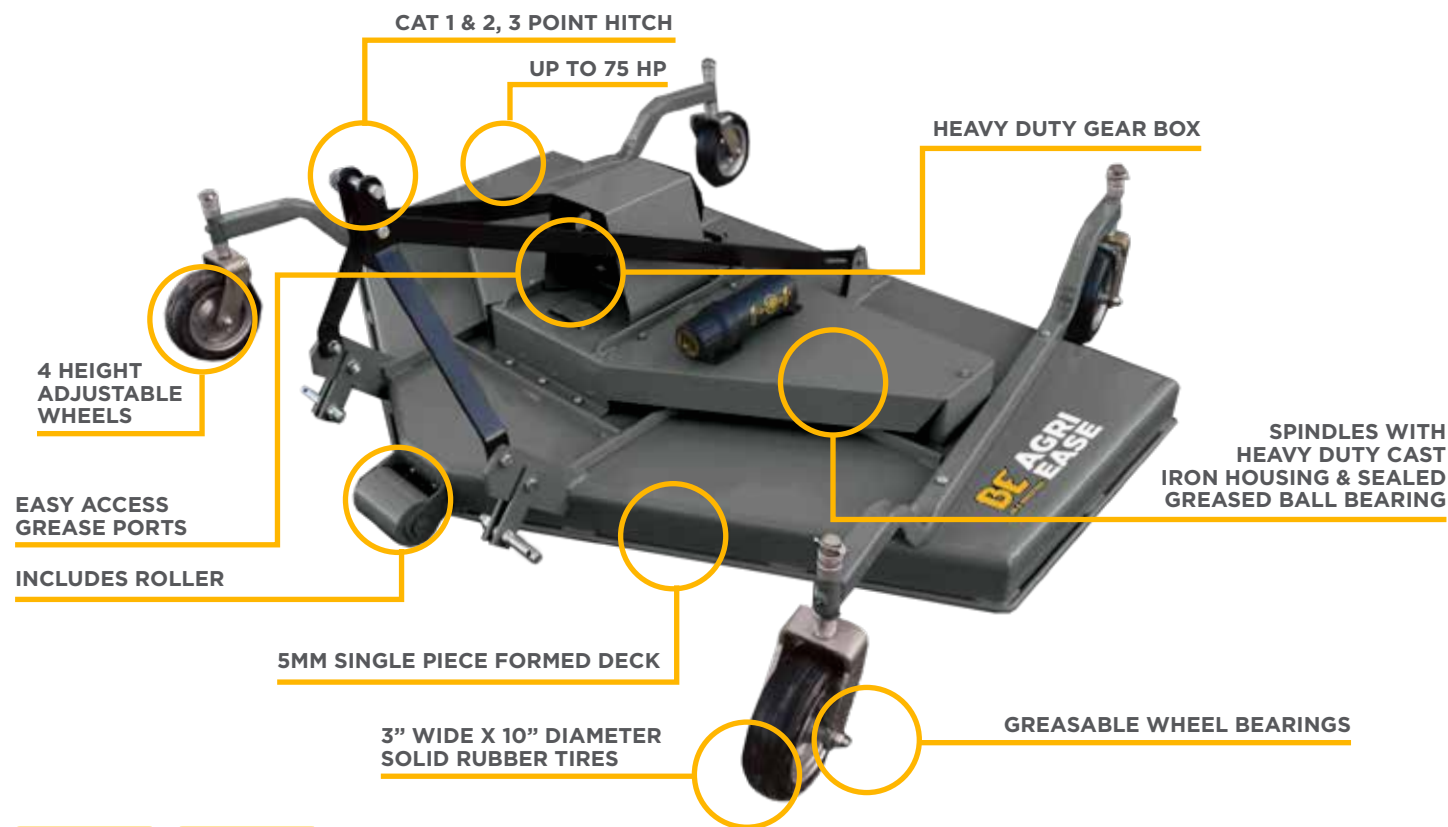

PART #	BE-FM84RDHDG
WEIGHT	728 LBS
WIDTH	84"
HP RATING	75 HP
CATEGORY	1, 2
BLADES	3
WHEEL SIZE	9-3/4" X 3"
MIN CUTTING HEIGHT	1-3/4"
MAX CUTTING HEIGHT	4-3/4"

## REPLACEMENT WEAR PARTS

BLADE	FM4.96HDG
V BELT	FM71.B914 FM72.B2591

**MASCHIO  
FINISH  
MOWER**

48", 60", 72", 83'

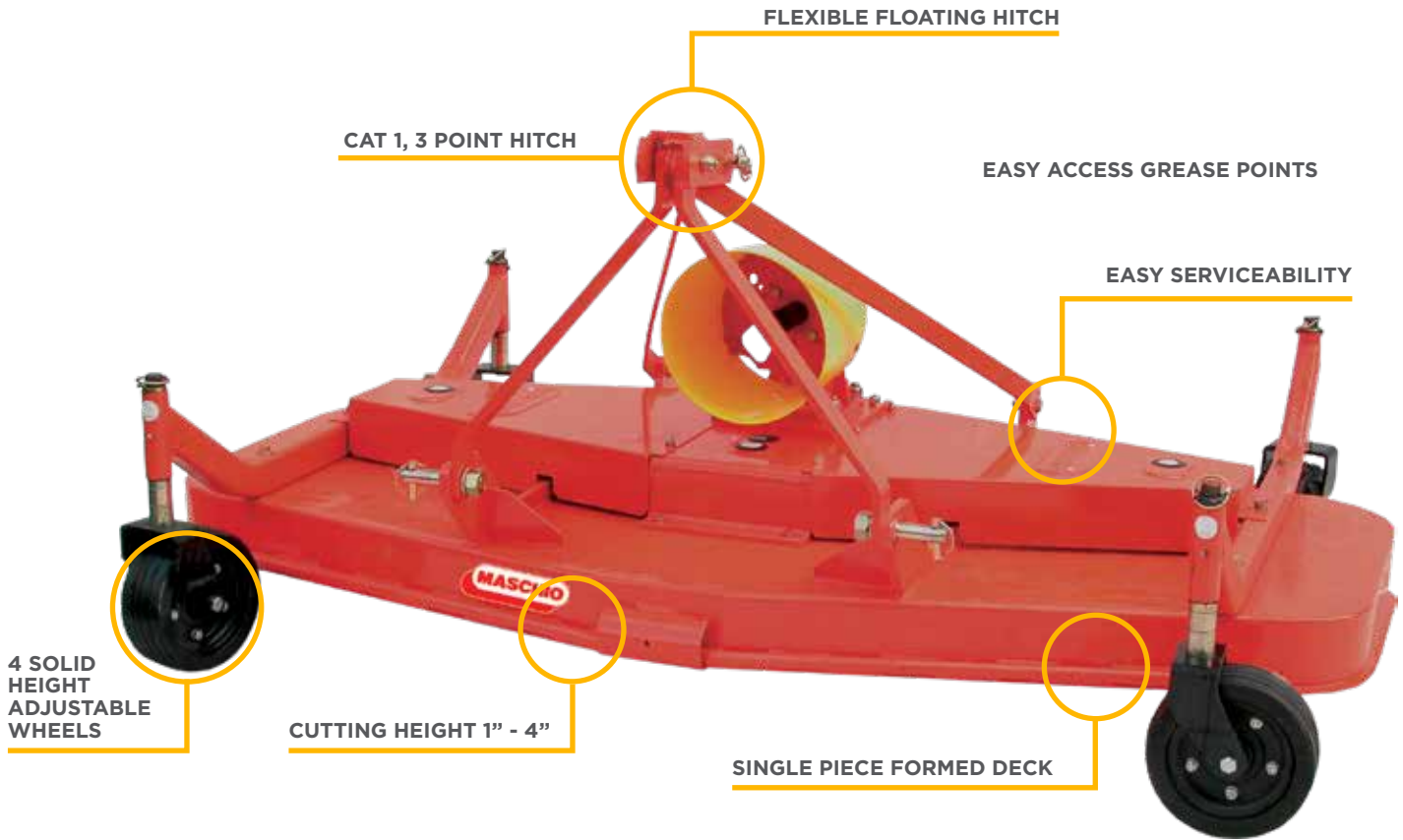

PART #	MAS-FM120RD	MAS-FM150RD	MAS-FM180RD	MAS-FM210RD
WEIGHT	370 LBS	418 LBS	506 LBS	803 LBS
WORKING WIDTH	48"	60"	72"	83"
HP RATING	14 - 40 HP	23 - 40 HP	32 - 40 HP	35 - 50 HP
BLADES	3	3	3	6 SWING BLADES, 3 SPINDLES
MIN CUTTING HEIGHT	1"	1"	1"	1"
MAX CUTTING HEIGHT	4"	4"	4"	4"

**REPLACEMENT WEAR PARTS**

BLADE	C48007710	C59006210	C71001000	T150-05-065
BELT	47.002.060	47.171.725	47.171.880	47.002.094

**FLAIL MOWERS - FIXED**

**FLAIL MOWER**

38", 40", 48", 56", 60", 64", 68", 78"

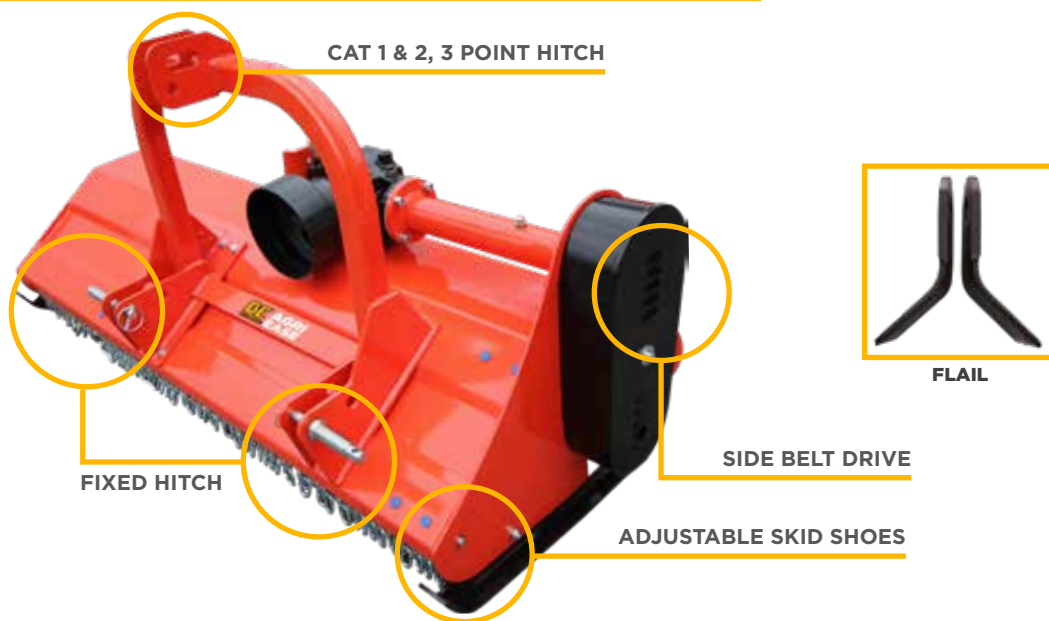

**540 RPM PTO INCLUDED**

**STANDARD PTO YOKE**

**CUTS UP TO 3/4" THICK MATERIAL\***

**3 BELT**

**OPTIONAL HAMMER EFGC120.104A**

\* CUTTING THICKNESS VARIES BY TRACTOR HP AND MATERIAL DENSITY

FLAIL PART #	BE-EFG95F	BE-EFGC105F	BE-EFGC125F	BE-EFGC145F	BE-EFGC155F	BE-EFGC165F	BE-EFGC175F	BE-EFGC200F
HAMMER PART #			BE-EFGC125H		BE-EFGC155H	BE-EFGC165H	BE-EFGC175H	BE-EFGC200H
WEIGHT	418 LBS	551 LBS	611 LBS	699 LBS	754 LBS	809 LBS	864 LBS	948 LBS
WORKING WIDTH	38"	40"	48"	56"	60"	64"	68"	78"
OVERALL WIDTH	44"	46"	54"	62.5"	66.5"	70.5"	74.5"	84.5"
OFFSET	24"   20"	22"   20"	17"   31"	24"   32"	24"   36"	28"   36"	28"   40"	33"   45"
HP RATING	18 - 25 HP	18 - 25 HP	18 - 25 HP	30 - 35 HP	30 - 40 HP	35 - 45 HP	40 - 50 HP	55 - 70 HP
FLAILS REQUIRED	32	32	40	48	48	56	56	64
HAMMERS REQUIRED	16	16	20	24	24	28	28	32

**REPLACEMENT WEAR PARTS FOR ALL UNITS**

PART#	BOLT	NYLOC NUT	V BELT	PTO	FLAIL	FLAIL SPACER	HAMMER
PART #	GB5782-86	GB6184-86	47.170.991	69.885.004	EFGC120.104	701240008	EFGC120.104A

**SHIFT KITS**



**2 TRACTOR HYDRAULIC PORTS REQUIRED**

PART #	EFGCMM120-HDJZH-PJ						EFGCHM120-HDJZH-PJ			EFGCHM200-HDJZH-PJ
POWER	MECHANICAL						HYDRAULIC			HYDRAULIC
WEIGHT	77 LBS						77 LBS			77 LBS
ATTACHES TO	BE-EFGC125-175									
SIDE SHIFT DISTANCES	BE-EFG95F	BE-EFGC105F	BE-EFGC125F	BE-EFGC145F	BE-EFGC155F	BE-EFGC165F	BE-EFGC175F			
		N/A	N/A	31.5"   17.75" 17.75"   31.5"	31.5"   25.5" 17.75"   39.5"	31.5"   29.5" 17.75"   43.5"	31.5"   33.5" 17.75"   47"	31.5"   37.5" 17.75"   51"	39.5"	39.5" 23.75"   55"

**FIXED  
FLAIL  
MOWER**

61"

WEEKEND *line*  
WARRIOR



SELF CLEANING ADJUSTABLE  
REAR LEVELING ROLLER

UNIVERSAL SELF-BALANCING  
CAT 1, 3 POINT HITCH

ELECTRONIC BALANCED ROTOR



OPTIONAL HAMMER  
484-00-405 OR 55.000.277

**OPTIONS**

**QUICK HITCH BRACKETS**  
MAS-99500107

**THIS MODEL IS SUITABLE FOR  
GRASS CUTTING AND GARDEN MAINTENANCE.**

**THE MACHINE CAN BE USED AT THE FRONT OR  
REAR OF THE TRACTOR.**

**THE ROTOR IS AVAILABLE WITH HAMMERS, SUITABLE  
FOR MOWING ORNAMENTAL LAWNS.**



REPLACEMENT  
GRASS FLAILS  
484-00-406



\* CUTTING THICKNESS VARIES BY TRACTOR HP AND MATERIAL DENSITY

PART #	MAS-BIRBA115F	MAS-BIRBA135F	MAS-BIRBA155F
WEIGHT	441 LBS	468 LBS	485 LBS
OVERALL WIDTH	52"	60"	68"
CUTTING WIDTH	45"	53"	61"
HP RATING	15 - 40 HP	20 - 40 HP	25 - 40 HP
HAMMERS	24	28	32
HITCH	CAT 1	CAT 1	CAT 1
GRASS FLAILS	48	56	64

**REPLACEMENT WEAR PARTS FOR ALL UNITS**

PART	OEM HAMMER	BE HAMMER	BELT
PART #	484-00-405	55.000.277	47.201.160



**FLAIL MOWERS - FIXED**

**MADE IN ITALY**  
**AGRIEASE**  
**FLAIL**  
**MOWER**  
WITH FIXED HITCH  
39", 51", 62"

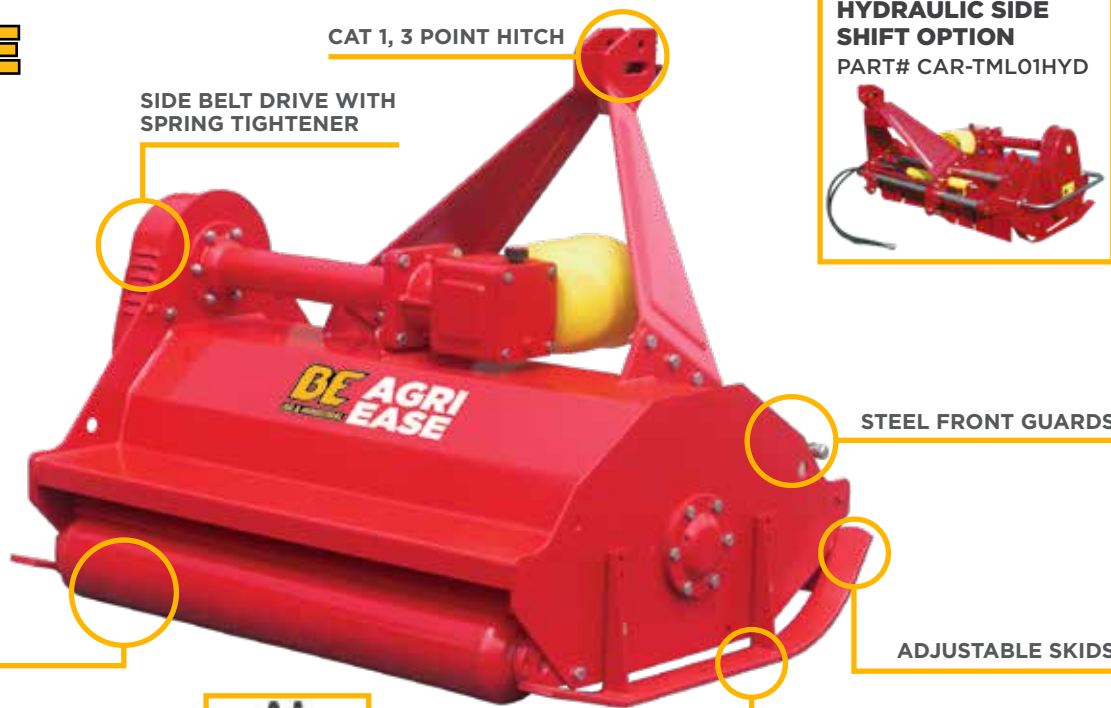

**TL SERIES FLAIL MOWER**

PART #	CAR-TL900	CAR-TL1200	CAR-TL1500
WEIGHT	400 LBS	412 LBS	472 LBS
OVERALL WIDTH	39"	51"	62"
CUTTING WIDTH	36"	48"	59"
OFFSET 	24"   16"	24"   26"	24"   36"
HP RATING	20 - 40 HP	20 - 40 HP	20 - 40 HP
BLADES	28	36	44
HITCH	FIXED	FIXED	FIXED

**REPLACEMENT WEAR PARTS FOR ALL UNITS**

PART	V BELT	BLADE	HEX BOLT	NYLOC NUT
PART #	47.171.090	55.000.051	01.010.045	09.000010

**HYDRAULIC SIDE SHIFT OPTION**

PART #	CAR-TML01HYD		
POWER	HYDRAULIC		
PORTS REQUIRED	2 TRACTOR HYDRAULIC PORTS		
ATTACHES TO	CAR-TL1200 & CAR-TL1500		
SIDE SHIFT DISTANCES 	CAR-TL900	CAR-TL1200	CAR-TL1500
	N/A	30"   18" 16"   31"	41"   18" 28"   31"

**MADE IN ITALY**  
**AGRIEASE**  
**FLAIL**  
**MOWER**

**WITH ADJUSTABLE HITCH**  
**52", 63", 75"**



CAT 1, 3 POINT HITCH

**HYDRAULIC SIDE SHIFT OPTION**  
PART# CAR-TML01HYD



**SIDE BELT DRIVE WITH SPRING TIGHTENER**

**ADJUSTABLE SKIDS**

**STEEL FRONT GUARDS**

**FULL WIDTH REAR ROLLERS**



\* CUTTING THICKNESS VARIES BY TRACTOR HP AND MATERIAL DENSITY



**DOUBLE GENERAL PURPOSE FLAIL BLADES**

TM BLADE



**540 RPM PTO INCLUDED**



**STANDARD PTO YOKE**



**CUTS UP TO 3/4" THICK MATERIAL\***

**TM SERIES FLAIL MOWER**

PART #	CAR-TM1300	CAR-TM1600	CAR-TM1900
WEIGHT	507 LBS	562 LBS	644 LBS
OVERALL WIDTH	54"	65"	75"
CUTTING WIDTH	52"	63"	73"
OFFSET 	24"   31"	24"   41"	24"   51"
HP RATING	20 - 60 HP	20 - 60 HP	30 - 60 HP
BLADES	40	48	56
HITCH	ADJUSTABLE	ADJUSTABLE	ADJUSTABLE

**REPLACEMENT WEAR PARTS FOR ALL UNITS**

PART	V BELT	BLADE	SHACKLE	HEX BOLT	NYLOC NUT
V BELT	47.171.090	55.000.038	55.000.052	01.010.080	09.000.010

**HYDRAULIC SIDE SHIFT OPTION**

PART #	CAR-TML01HYD		
POWER	HYDRAULIC		
PORTS REQUIRED	2 TRACTOR HYDRAULIC PORTS		
ATTACHES TO	CAR-TM1300, CAR-TM1600 & CAR-TM1900		
SIDE SHIFT DISTANCES 	CAR-TM1300	CAR-TM1600	CAR-TM1900
	33"   18" 20"   31"	45"   18" 31"   31"	57"   18" 43"   31"



**HEAVY  
DUTY  
MULCHER/  
SHREDDER**

74", 78", 86", 94"

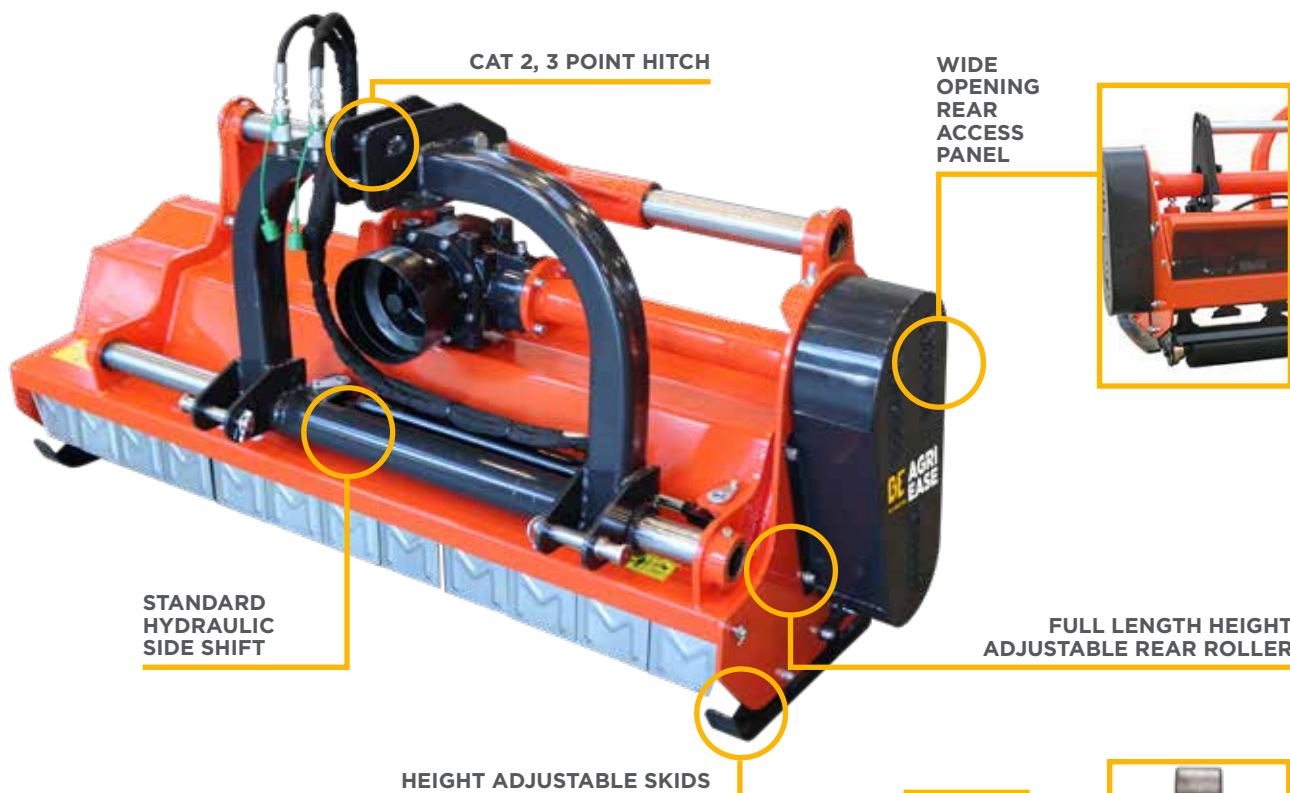

**CUTS UP TO  
1-1/2"  
THICK  
MATERIAL\***

\* CUTTING THICKNESS VARIES BY TRACTOR HP AND MATERIAL DENSITY



**PIONEER TYPE  
HYDRAULIC  
FITTINGS**



**REPLACEMENT  
HAMMER  
EFAG140.103**

PART #	BE-AGMZ180	BE-AGMZ200	BE-AGMZ220	BE-AGMZ240
WEIGHT	1323	1345	1425	1512
WIDTH	78"	85"	93"	100"
WORKING WIDTH	71"	78"	86"	94"
HP RATING	30 - 45 HP	30 - 45 HP	45 - 75 HP	45 - 75 HP
BLADES	20	20	24	24
HITCH	CAT 2	CAT 2	CAT 2	CAT 2
HYDRAULIC PORTS	2	2	2	2
BELTS	5	5	5	5

**REPLACEMENT WEAR PARTS**

REPLACEMENT HAMMER	EFAG140.103	EFAG140.103	EFAG140.103	EFAG140.103
--------------------	-------------	-------------	-------------	-------------

**MADE IN ITALY**  
**HEAVY DUTY**  
**TFB SERIES**  
**LOW PROFILE**  
**SHREDDER**

47" UP TO 118"

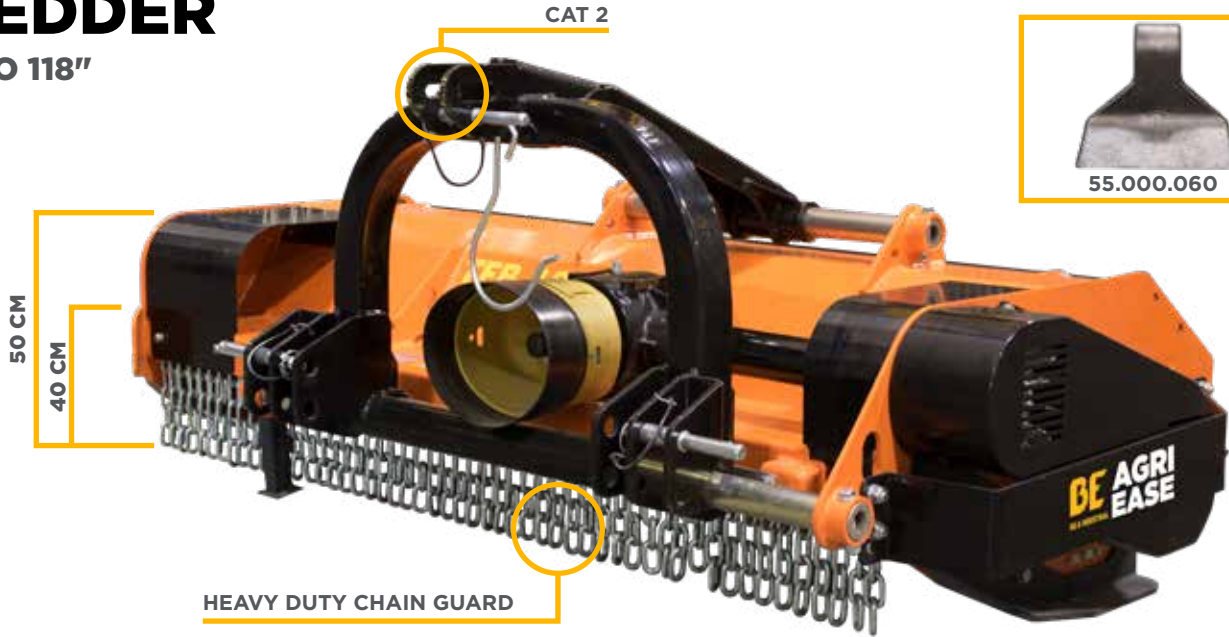

**GRASS FLAIL SET**  
PART# TFBGRFL



**THE REDUCED BODY HEIGHT OF THE TFB MODEL IS IDEAL FOR THE PRUNING OF SHRUBS AS WELL AS THE CLEANING OF ORCHARDS AND VINEYARDS.**

**IT IS IDEAL FOR MULCHING GRASS, CORN, HAY, PRUNING WASTE, BRUSHWOOD AND MORE.**

**540 RPM PTO**  
INCLUDED

**STANDARD PTO YOKE**

**OPTIONS**  
**TWIG RAKE TEETH FOR FINER SHREDDING.**  
5210142

A = 18"  
B = 8-5/8"

**CUTS UP TO 4" THICK MATERIAL\***

\* CUTTING THICKNESS VARIES BY TRACTOR HP AND MATERIAL DENSITY

PART #	SIZE	HP RATING	WORKING WIDTH	OVERALL WIDTH	WEIGHT (LBS)	# OF HAMMERS	# OF RAKE TEETH
BE-TFB1200	47"	30 - 40 HP	47"	57"	1080	10	10
BE-TFB1400	55"	35 - 60 HP	55"	64"	1124	12	12
BE-TFB1500	59"	40 - 70 HP	59"	67"	1190	12	14
BE-TFB1600	63"	40 - 70 HP	63"	72"	1256	14	16
BE-TFB1800	71"	50 - 70 HP	71"	80"	1300	16	18
BE-TFB2000	79"	60 - 80 HP	79"	87"	1433	18	19
BE-TFB2200	87"	70 - 90 HP	87"	96"	1521	20	20
BE-TFB2400	94"	80 - 100 HP	94"	103"	1631	20	21
BE-TFB2600	102"	90 - 100 HP	102"	111"	1741	22	22
BE-TFB3000	118"	110 - 150 HP	118"	118"	1984	26	24
BE-TFBHYDSFT	HYDRAULIC OFFSET OPTION						
TFBGRFL	GRASS FLAIL SET/HAMMER LOBE						

**REPLACEMENT WEAR PARTS**

PART	HAMMER	BELT
PART #	55.000.060	5354049



**SHREDDERS**

 **MADE IN ITALY**

**EXTRA  
HEAVY DUTY  
TMS SERIES  
MULCHER**  
55" UP TO 102"

**GRASS FLAIL SET**  
PART# TFBGRFL



**THE TMS MULCHER IS DESIGNED FOR MOUNTING ON MEDIUM TO HIGH POWER TRACTORS (60-120 HP). IT IS IDEAL FOR MULCHING GRASS, CORN, HAY, PRUNING WASTE, BRUSHWOOD AND MORE.**

**540**  
RPM PTO  
  
INCLUDED

  
**STANDARD**  
PTO YOKE

**OPTIONS**  
  
**TWIG RAKE TEETH**  
FOR FINER SHREDDING.  
5210142

  
A = 21-5/8"  
B = 6-5/8"

**CUTS UP TO**  
**4-3/4"**  
**THICK MATERIAL\***

\* CUTTING THICKNESS VARIES BY TRACTOR HP AND MATERIAL DENSITY

PART #	SIZE	HP RATING	WORKING WIDTH	OVERALL WIDTH	WEIGHT (LBS)	RPM	# OF HAMMERS	# OF TWIG RAKE TEETH
BE-TMS1550	61"	60 - 80 HP	61"	71"	1830	540	12	13
BE-TMS1850	73"	60 - 80 HP	73"	81"	1984	540	14	15
BE-TMS2050	81"	70 - 110 HP	81"	89"	2150	540	16	17
BE-TMS2300	91"	90 - 110 HP	91"	98"	2315	540	18	19
BE-TMS2600	102"	70 - 120 HP	102"	110"	2447	540	22	22

**REPLACEMENT WEAR PARTS**

PART	TWIG RAKE TOOTH	REPLACEMENT HAMMER	BELT
PART #	5210142	55.535.098	5354058

 **MADE IN ITALY**

**EXTRA  
HEAVY DUTY  
TRP SERIES  
FRONT MOUNT  
REVERSIBLE  
MULCHER**

65", 73"

**GRASS FLAIL SET**  
PART# TFBGRFL



**THE TRP REVERSIBLE MULCHER IS DESIGNED FOR FRONT OR REAR MOUNTING ON MEDIUM TO HIGH POWER TRACTORS (50-130 HP).**

**IT IS IDEAL FOR MULCHING GRASS, CORN, HAY, PRUNING WASTE, BRUSHWOOD AND MORE.**

\*WHILE SUPPLIES LAST

**540 RPM PTO**  
  
INCLUDED

  
**STANDARD PTO YOKE**

**OPTIONS**  
  
**TWIG RAKE TEETH FOR FINER SHREDDING.**  
5210142

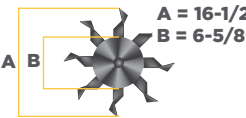
  
A = 16-1/2"  
B = 6-5/8"

**CUTS UP TO 4"**  
**THICK MATERIAL\***

\* CUTTING THICKNESS VARIES BY TRACTOR HP AND MATERIAL DENSITY

PART #	SIZE	HP RATING	WORKING WIDTH	OVERALL WIDTH	WEIGHT (LBS)	RPM	# OF HAMMERS	# OF TWIG RAKE TEETH
BE-TRP1650*	65"	50 - 120 HP	65"	78"	1654	540	14	14
BE-TRP1850*	73"	50 - 120 HP	73"	86"	1742	540	16	16

**REPLACEMENT WEAR PARTS**

PART	TWIG RAKE TOOTH	REPLACEMENT HAMMER	BELT
PART #	5210142	55.535.110	5354058



**BOOM MOWERS**

**3 POINT  
OFFSET  
BOOM  
MOWER**  
50", 56", 63"

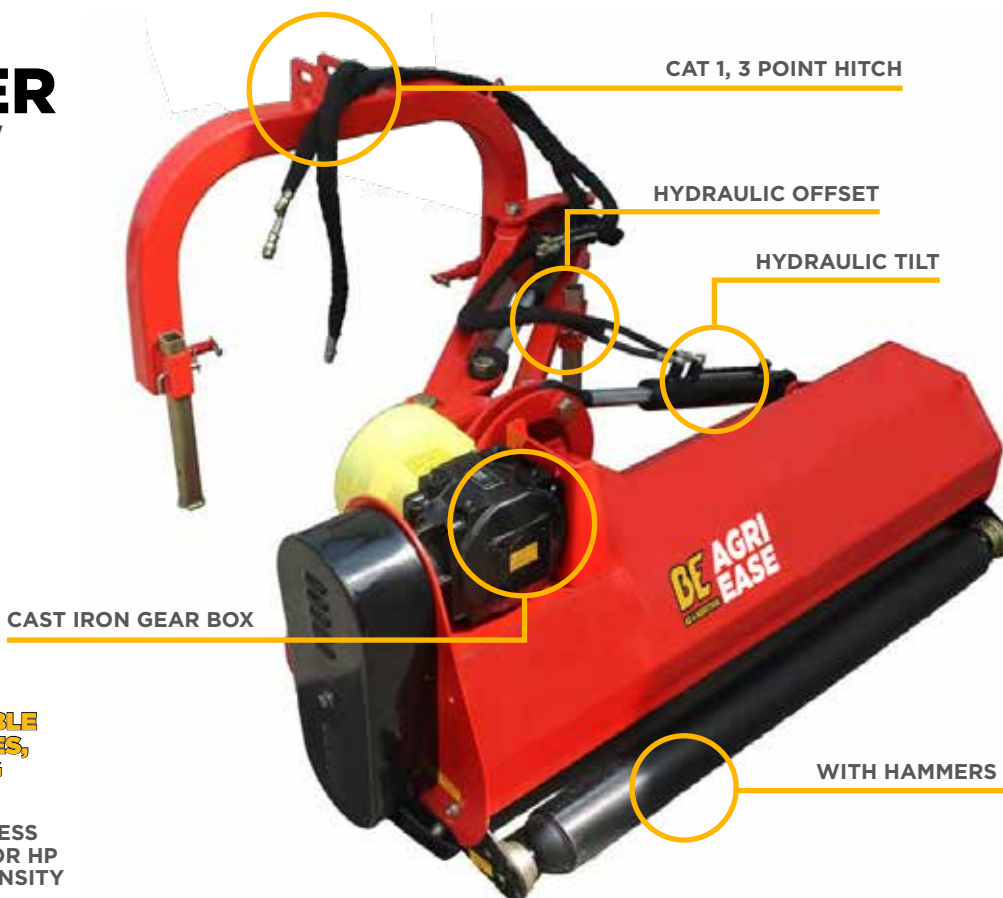

**FOR  
GRASS, VEGETABLE  
RESIDUE, BUSHES,  
AND PRUNING**

\* CUTTING THICKNESS  
VARIES BY TRACTOR HP  
AND MATERIAL DENSITY

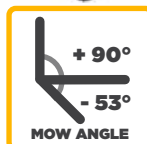

GRASS KNIVES  
AVAILABLE

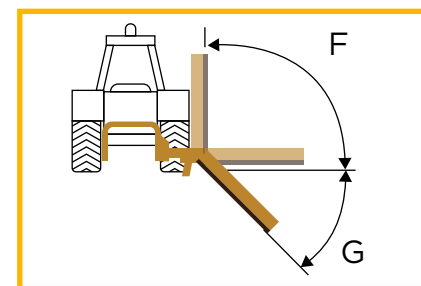
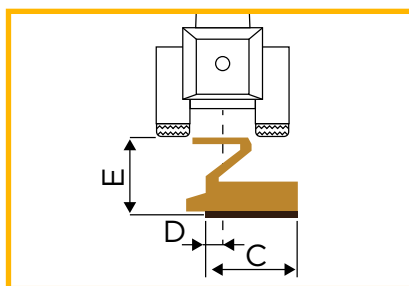
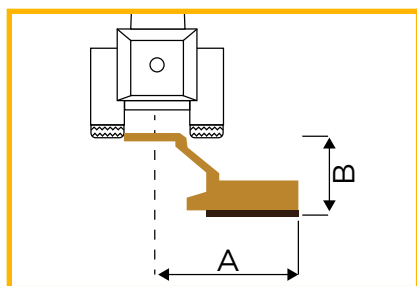

PART #	WEIGHT (LBS)	WIDTH	HP RATING	# OF HAMMERS	A	B	C	D	E	F	G
BE-AGL125F	695	50"	20 - 40 HP	20	65-1/2"	59-1/2"	48-3/4"	29-1/2"	49-1/2"	+90°	-53°
BE-AGL145F	735	56"	30 - 50 HP	24	73-1/4"	59-1/2"	56-3/4"	29-1/2"	49-1/2"	+90°	-53°
BE-AGL165F	770	63"	30 - 50 HP	28	81"	59-1/2"	64-1/2"	29-1/2"	49-1/2"	+90°	-53°

**OPTIONAL FLAIL KNIVES FOR ALL UNITS**

PART	HAMMER PART#	KNIFE PART#	SPACER PART#
PART #	701140011	EFR105.102	700920091

# 3 POINT OFFSET BOOM MOWER

54", 78"

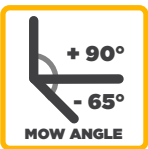
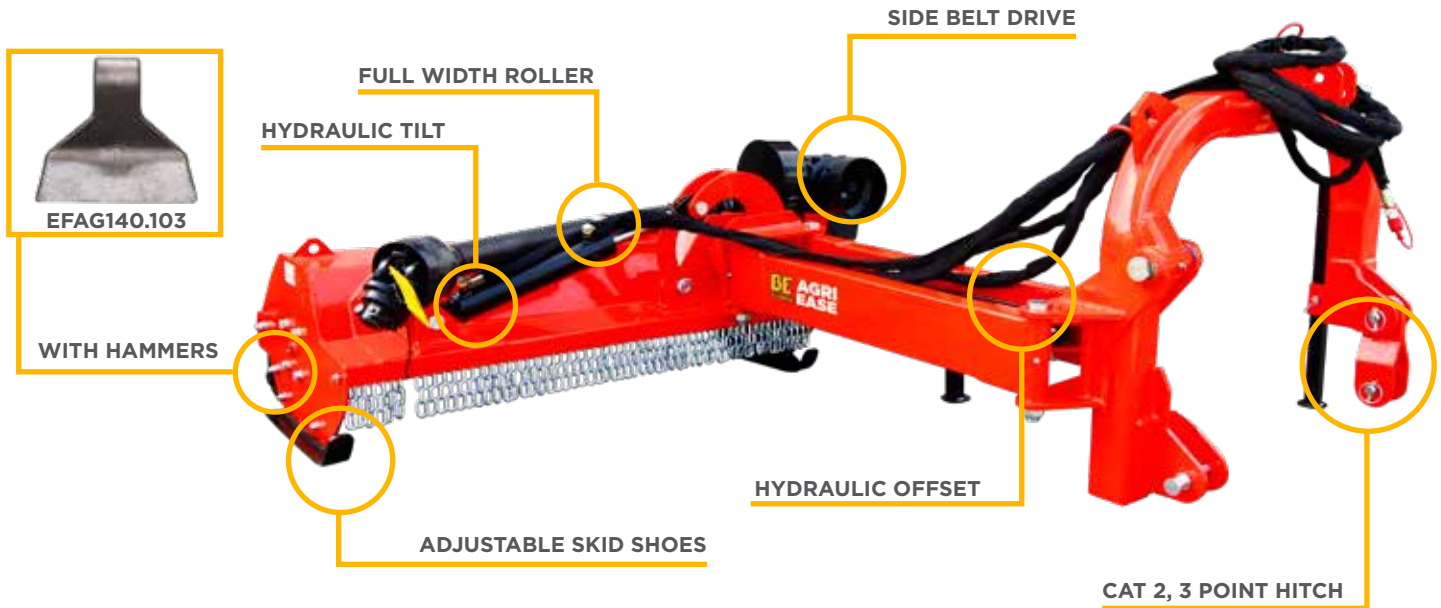

\* AVAILABLE WITH HAMMERS ONLY

\* CUTTING THICKNESS  
VARIES BY TRACTOR HP  
AND MATERIAL DENSITY

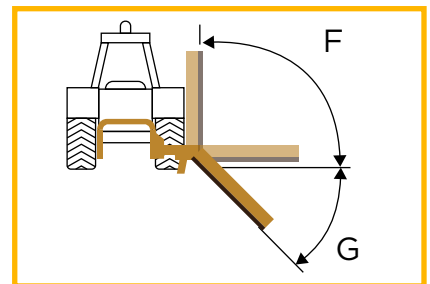
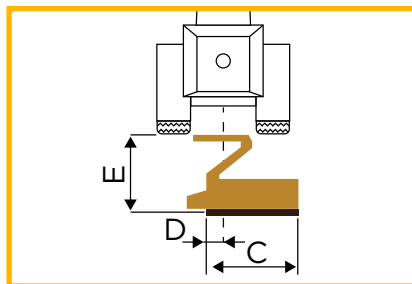
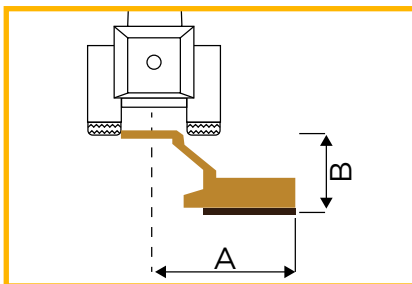

PART #	WEIGHT (LBS)	WIDTH	HP RATING	HAMMERS	A	B	C	D	E	F	G
BE-AGF140	1080	54"	40 - 85 HP	12	91-1/2"	72-1/2"	54-3/4"	18-1/2"	65-1/2"	+90°	-65°
BE-AGF200	1764	78"	80 - 120 HP	20	99-1/2"	72-1/2"	62-1/2"	18-1/2"	65-1/2"	+90°	-65°

# HEAVY DUTY VERGE MOWER

87"

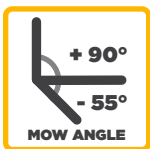
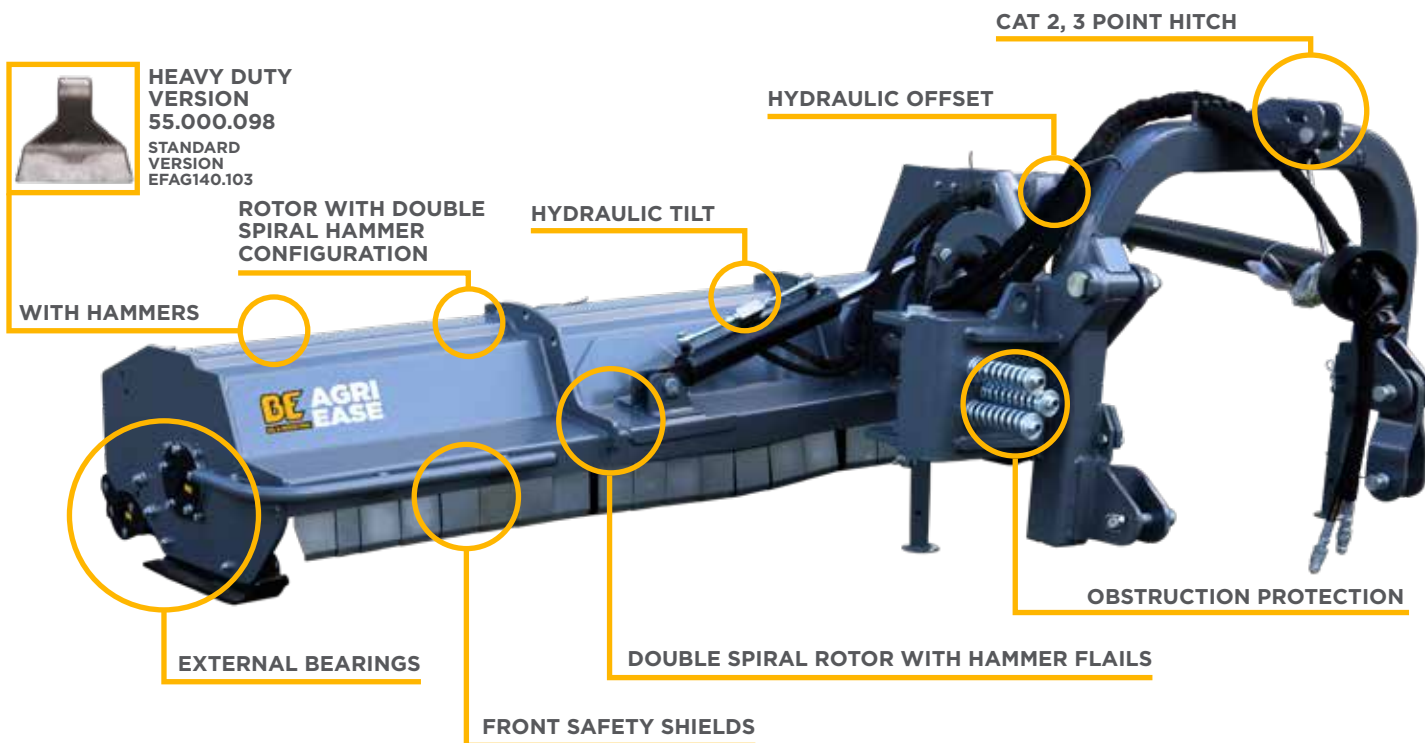

\* AVAILABLE WITH HAMMERS ONLY

PART #	BE-VBM220
WEIGHT	1772 LBS
WORKING WIDTH	87"
TOTAL WIDTH	108"
HP RATING	90 - 120 HP
HAMMERS	20
A	86"
B	92"
D	113"
E	84"

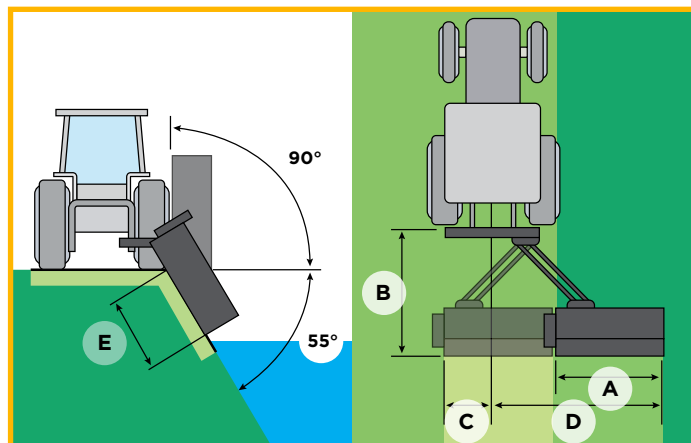

**FLAIL MOWERS - BOOM**

**MADE IN ITALY**  
**BOOM MOWER**  
**115"**



OPTIONAL GRASS FLAILS  
5350127



\* MAY NOT BE EXACTLY AS SHOWN

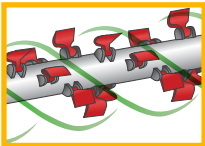
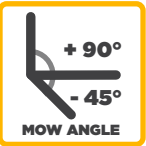

\* CUTTING THICKNESS VARIES BY TRACTOR HP AND MATERIAL DENSITY

PART #	BE-TMHP220
WEIGHT	1852 LBS
WIDTH	115"
WORKING WIDTH	87"
HP RATING	90 - 150 HP
HAMMERS	28
A	127-1/2"
B	90"
C	109-1/2"
D	39-1/2"
E	66"

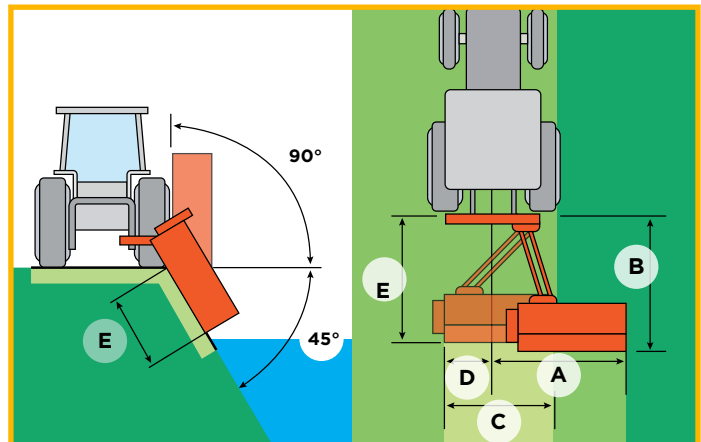

**REPLACEMENT WEAR PARTS**

PART	GRASS FLAILS	SPACER
PART #	5350127	5210316



**FLAIL MOWERS - BOOM**

**MASCHIO  
3 POINT HITCH  
BOOM  
FLAIL**

**WITH FIXED HITCH  
45", 61"**

**NEW!**

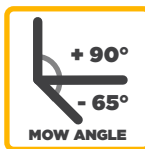
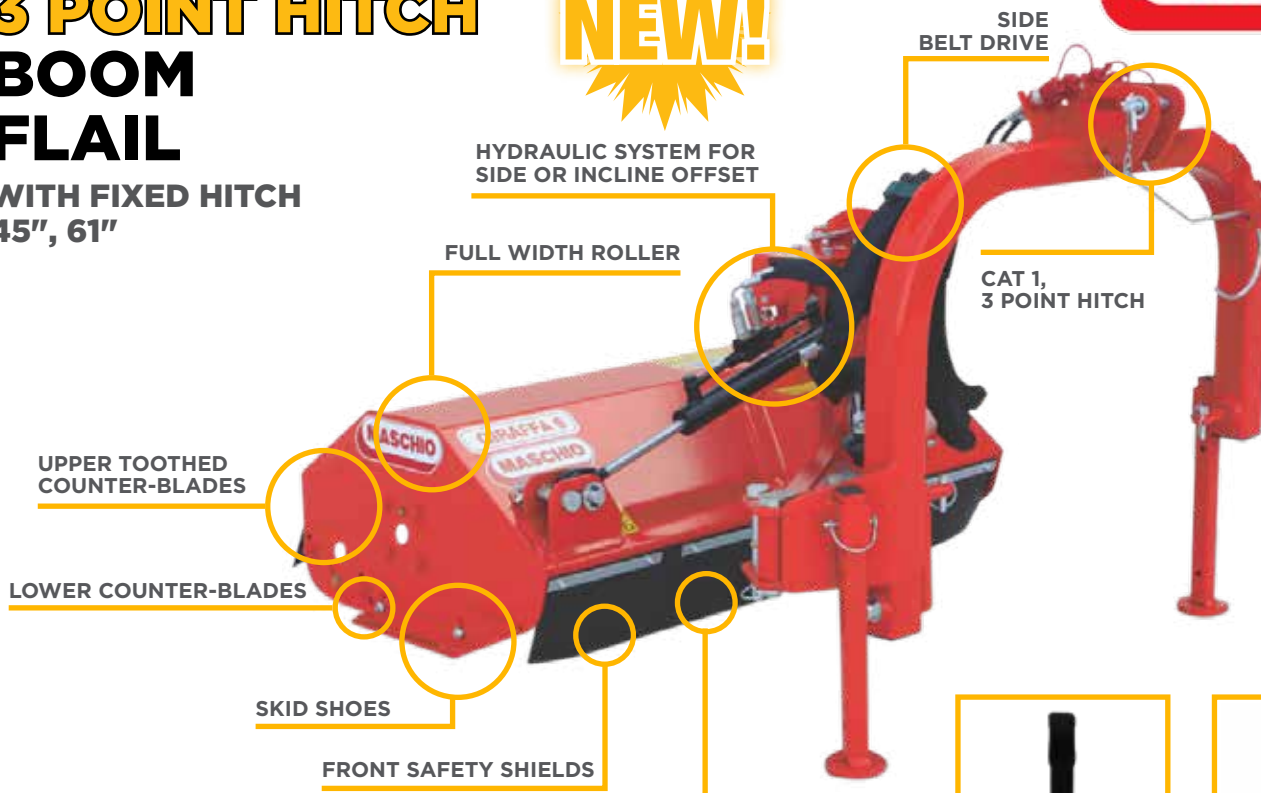

HAMMER BLADE  
484-00-405



OPTIONAL  
GRASS FLAILS  
AVAILABLE  
484-00-406

\* CUTTING THICKNESS VARIES BY TRACTOR HP AND MATERIAL DENSITY

**GIRAFFA 3 POINT BOOM MOWERS**

PART #	MAS-GIRAFFAS120	MAS-GIRAFFAS140	MAS-GIRAFFAS160
WEIGHT	593 LBS	633 LBS	664 LBS
WORKING WIDTH	45"	57"	61"
TOTAL WIDTH	52"	61"	69"
HP RATING	15 - 35 HP	20 - 35 HP	25 - 35 HP
OPTIONAL GRASS KNIVES	48	56	64
STANDARD HAMMER	24	28	32
BELTS	3	3	3
A	45"	53"	61"
B	50"	50"	50"
C	22"	22"	22"
D	68"	76"	83"
E	35"	43"	50"

OTHER SIZES AND CONFIGURATIONS AVAILABLE BY SPECIAL ORDER

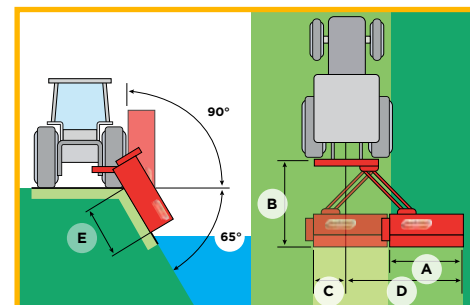

**REPLACEMENT WEAR PARTS**

PART	GRASS FLAILS	V BELT	HAMMER BLADE
PART #	484-00-406	060-10-062	484-00-405

**MASCHIO**  
**3 POINT HITCH**  
**BOOM**  
**FLAIL**

WITH FIXED HITCH  
62", 75", 84"

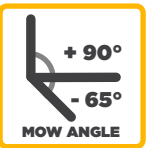
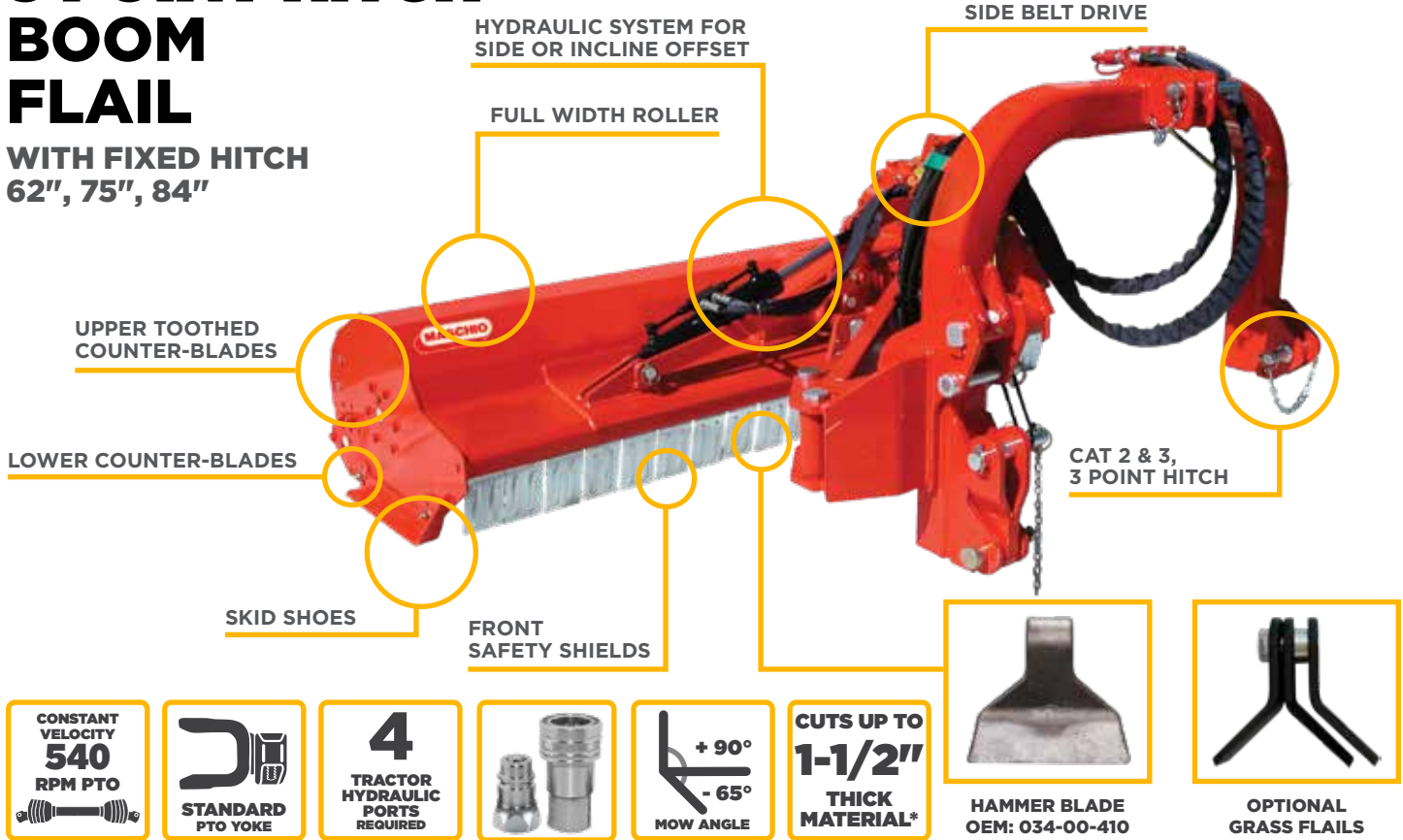

**HAMMER BLADE**  
OEM: 034-00-410  
BE VERSION  
55.034.410



**OPTIONAL GRASS FLAILS AVAILABLE**  
55.000.043

\* CUTTING THICKNESS VARIES BY TRACTOR HP AND MATERIAL DENSITY

**GIRAFFA 3 POINT BOOM MOWERS**

PART #	MAS-GIRAFFA160	MAS-GIRAFFA185	MAS-GIRAFFA210SE
WEIGHT	1210 LBS	1276 LBS	1364 LBS
WIDTH	62"	75"	84"
TOTAL WIDTH	70"	91"	100"
HP RATING	50 - 110 HP	60 - 110 HP	70 - 110 HP
OPTIONAL GRASS KNIVES	36	48	60
STANDARD HAMMER	18	24	30
HITCH	ADJUSTABLE	ADJUSTABLE	ADJUSTABLE
BELTS	4	4	4
A	62"	75"	83"
B	67"	67"	67"
C	53"	53"	53"
D	104"	116"	126"
E	59"	72"	81"

OTHER SIZES AND CONFIGURATIONS AVAILABLE BY SPECIAL ORDER

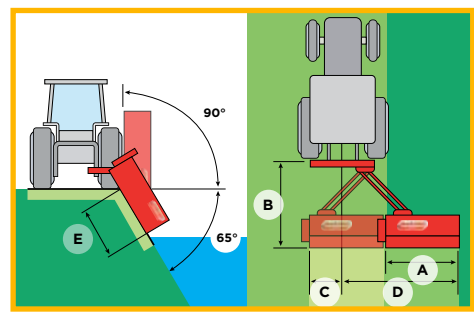

**REPLACEMENT WEAR PARTS**

PART	GRASS FLAILS	V BELT	HAMMER BLADE
PART #	55.000.043	47.201.320	55.034.410

\*SE: SIDE MOUNTED GEARBOX

**HEDGE TRIMMERS**

**HEDGE TRIMMER BOOM MOWER**

31-1/2"



FOLDS UP FOR EASY TRANSPORT

**FOR CUTTING GRASS & LIGHT BRUSH**

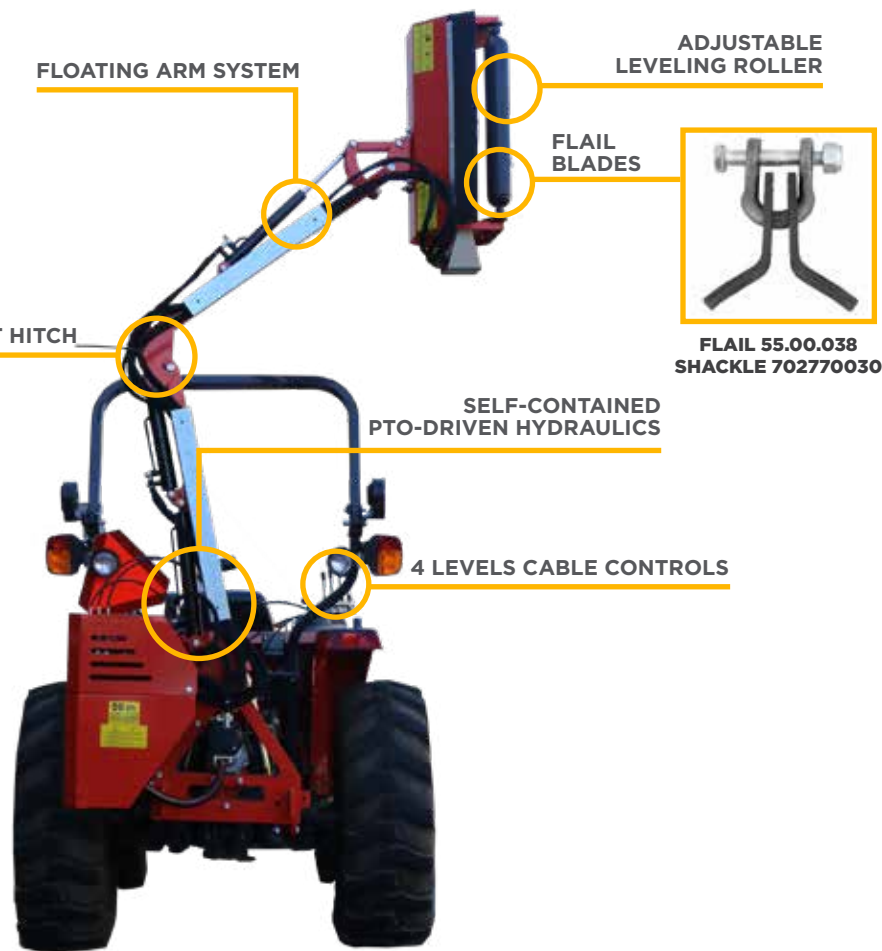

PART #	BE-AM80
WEIGHT	606 LBS
WIDTH	31-1/2"
HP RATING	20 - 50 HP
BLADES	32
A	122"
B	150"
C	94"
D	94"
E	114"
F	43"

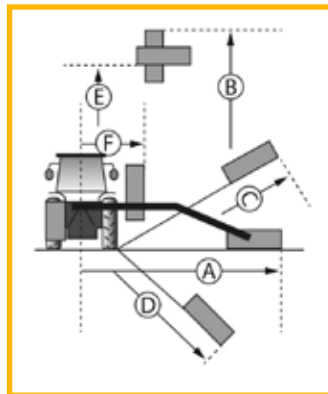

**HEDGE TRIMMER BOOM MOWER ATTACHMENT**

PART #	AMHT130	AMHT160	AMHT190
LENGTH	51"	63"	75"

**REPLACEMENT WEAR PARTS**

PART	KNIFE	RIVETS
PART#	705640020	512020143



# FORESTRY MULCHER

78"

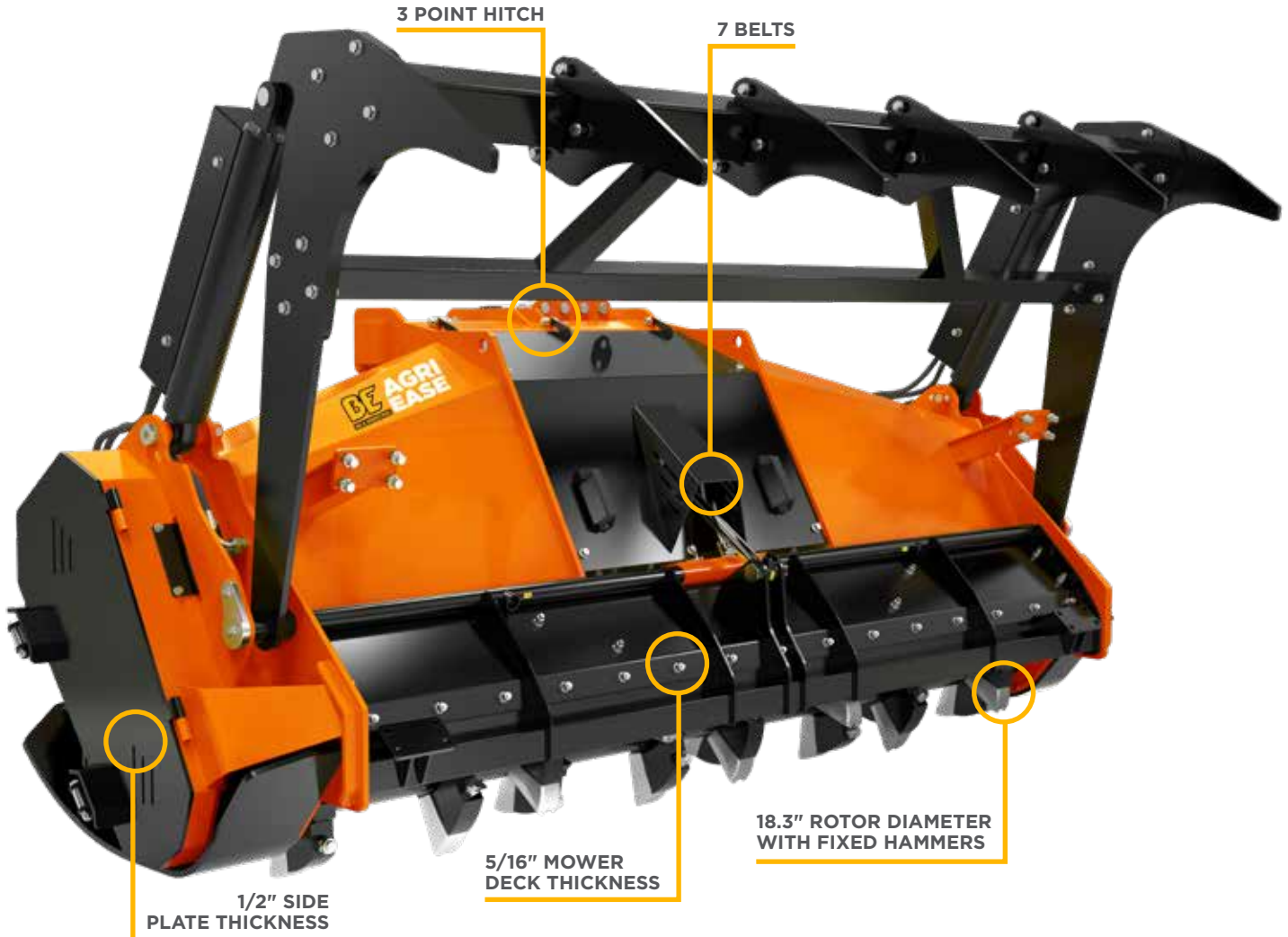

3 POINT HITCH

7 BELTS

1/2" SIDE  
PLATE THICKNESS

5/16" MOWER  
DECK THICKNESS

18.3" ROTOR DIAMETER  
WITH FIXED HAMMERS

PART #	BE-FMC78
HITCH	CATEGORY 2 OR 3N
WEIGHT	3307 LBS
WORKING WIDTH	78"
WORKING DEPTH	-70MM, -30MM, +10MM (3 POSITIONS)
MAX CHIPPING DIAMETER	8"
HAMMERS	32
HP RATING	70 - 110 HP
GEARBOX	100 HP / 1000 RPM

## REPLACEMENT WEAR PARTS

PART	BELT	CUTTING TOOTH	BOLT	LOCK NUT
PART #	104.103D.001	104.103D.102	104.103D.101	104.103D.103



**ROTARY TEDDERS & RAKES**



 **MADE IN ITALY**

**BELT  
RAKE**

**84"**

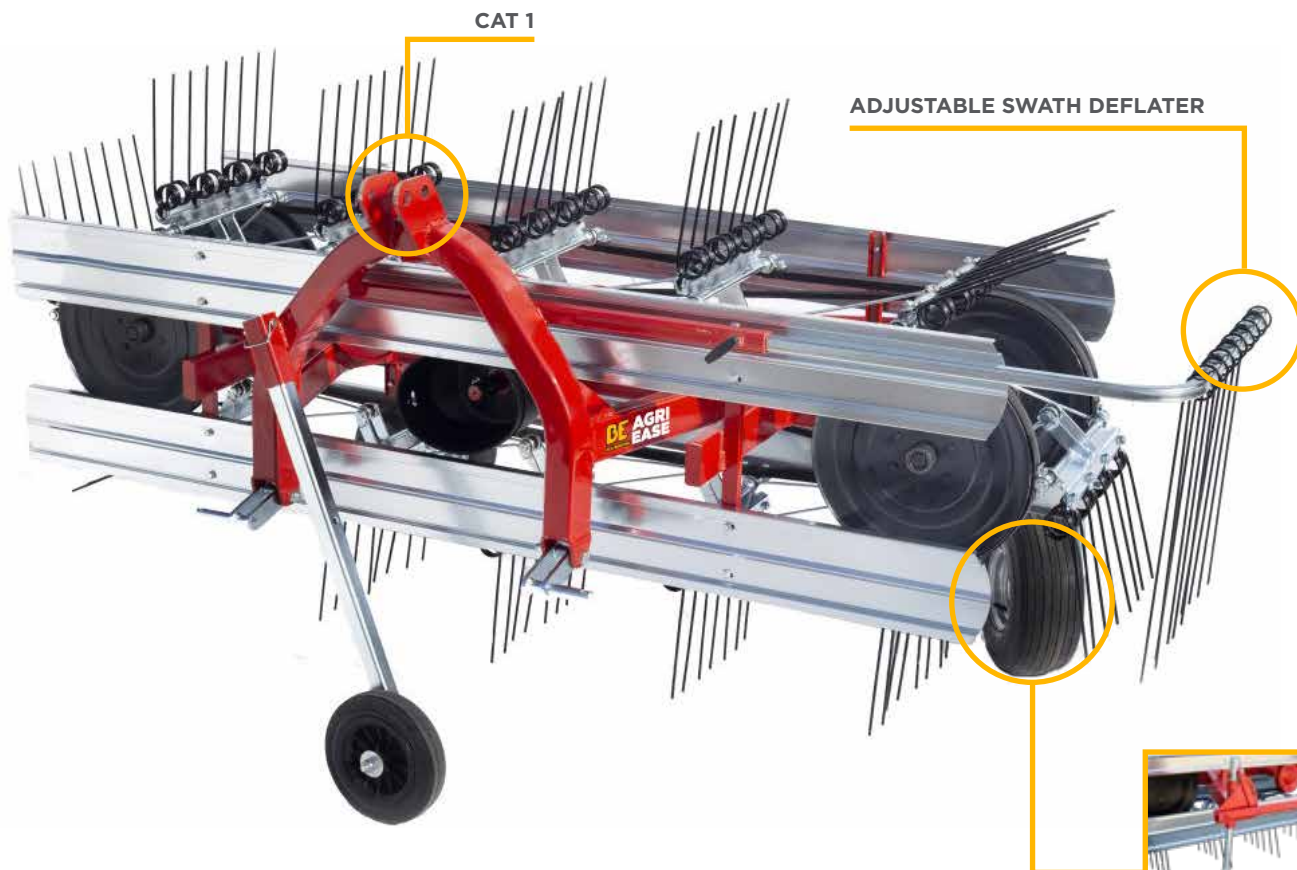

**IDEAL FOR  
USE ON  
HAY FIELDS  
WITH HILLS**



**ADJUSTABLE  
GROUND CONTACT  
HEIGHT**

PART #	BE-D210DR
WEIGHT	463 LBS
WORKING WIDTH	84"
TRANSPORT WIDTH	88"
HP RATING	20 HP
TEETH	4 TEETH / ROW
ROWS	14
HITCH	3 POINT

**MADE IN ITALY**  
**3 POINT**  
**ROTARY**  
**RAKE**  
96", 120", 132"

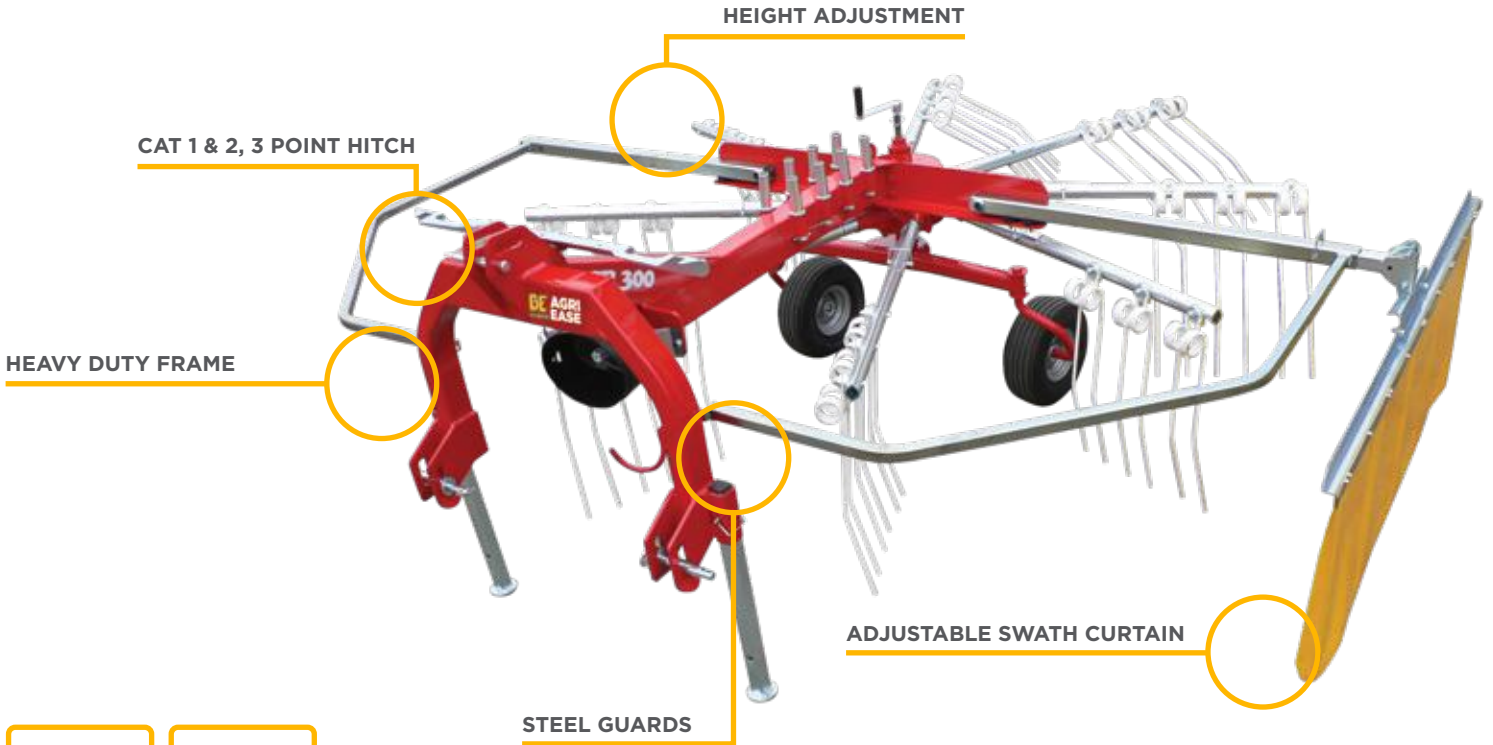

PART #	SWIVEL WHEEL		
	BE-GR250DR	BE-GR300DR	BE-GR330DR
WEIGHT	616 LBS	704 LBS	748 LBS
WORKING WIDTH	96"	120"	132"
TRANSPORT WIDTH	52"	52"	52"
HP RATING	20 HP	25 HP	30 HP
WHEELS	2 SWIVEL	2 SWIVEL	2 SWIVEL
DOUBLE TEETH/ARM	3	3	3
ARMS	8	8	9
HITCH	3 POINT	3 POINT	3 POINT

**REPLACEMENT WEAR PARTS FOR ALL UNITS**

PART	PTO PART 1	PTO PART 2	TINES
PART #	69.888.002	611234005	45.000.220



**ROTARY TEDDERS & RAKES**

**MADE IN ITALY**  
**TANDEM**  
**ROTARY**  
**RAKE**

132", 162"

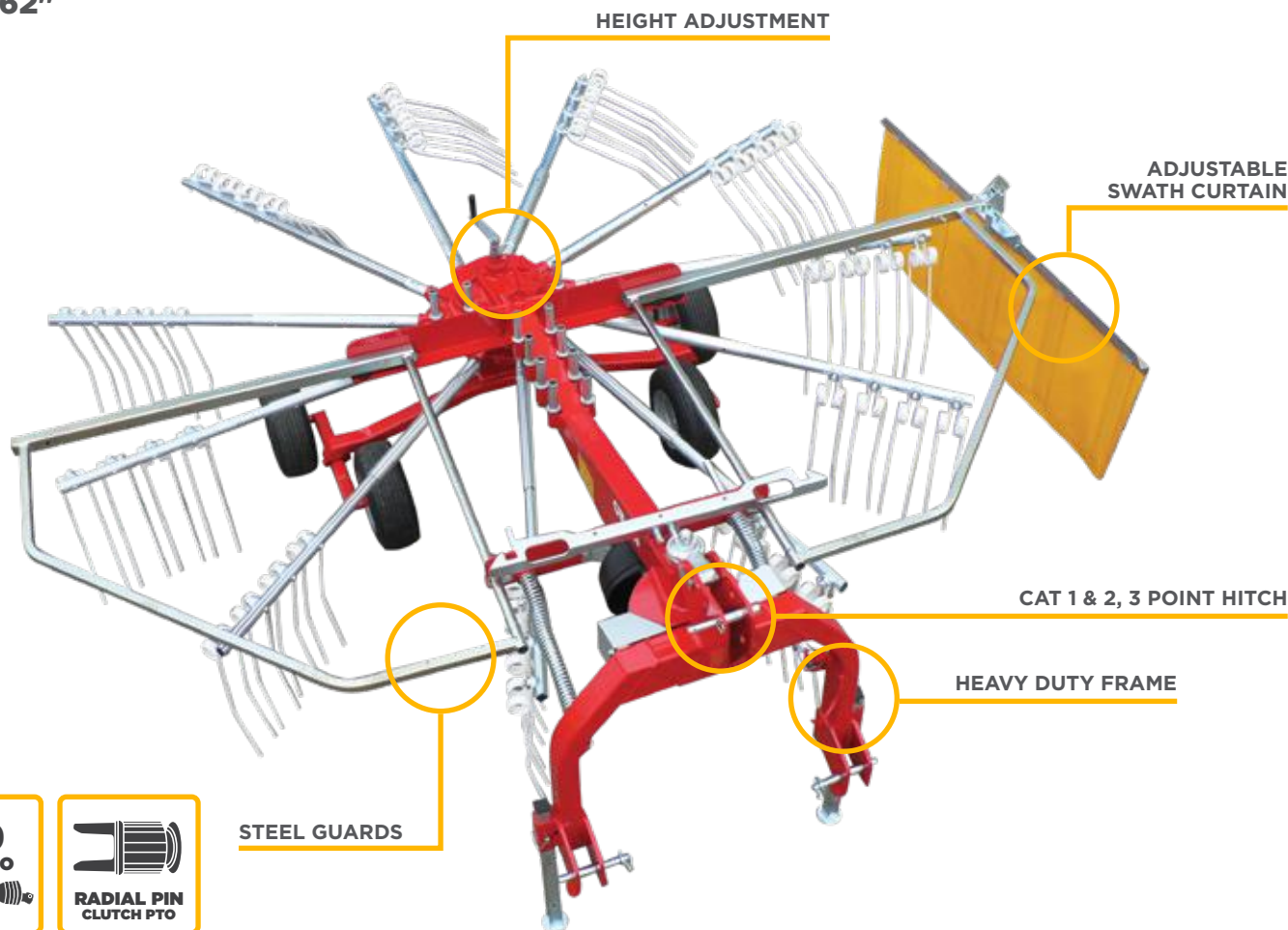

PART #	TANDEM WHEEL		
	BE-GR300DRTM	BE-GR330DRTM	BE-GR410DR
WEIGHT	880 LBS	1298 LBS	1210 LBS
WORKING WIDTH	120"	132"	162"
TRANSPORT WIDTH	52"	52"	59"
HP RATING	30 HP	40 HP	40 HP
WHEELS	TANDEM	TANDEM	TANDEM
DOUBLE TEETH/ARM	3	4	4
ARMS	9	11	11
HITCH	3 POINT	3 POINT	3 POINT

**REPLACEMENT WEAR PARTS FOR ALL UNITS**

PART	PTO PART 1	PTO PART 2	TINES
PART #	69.888.002	611234005	45.000.220



**MADE IN ITALY**  
**TRAILED**  
**ROTARY**  
**RAKE**  
132"

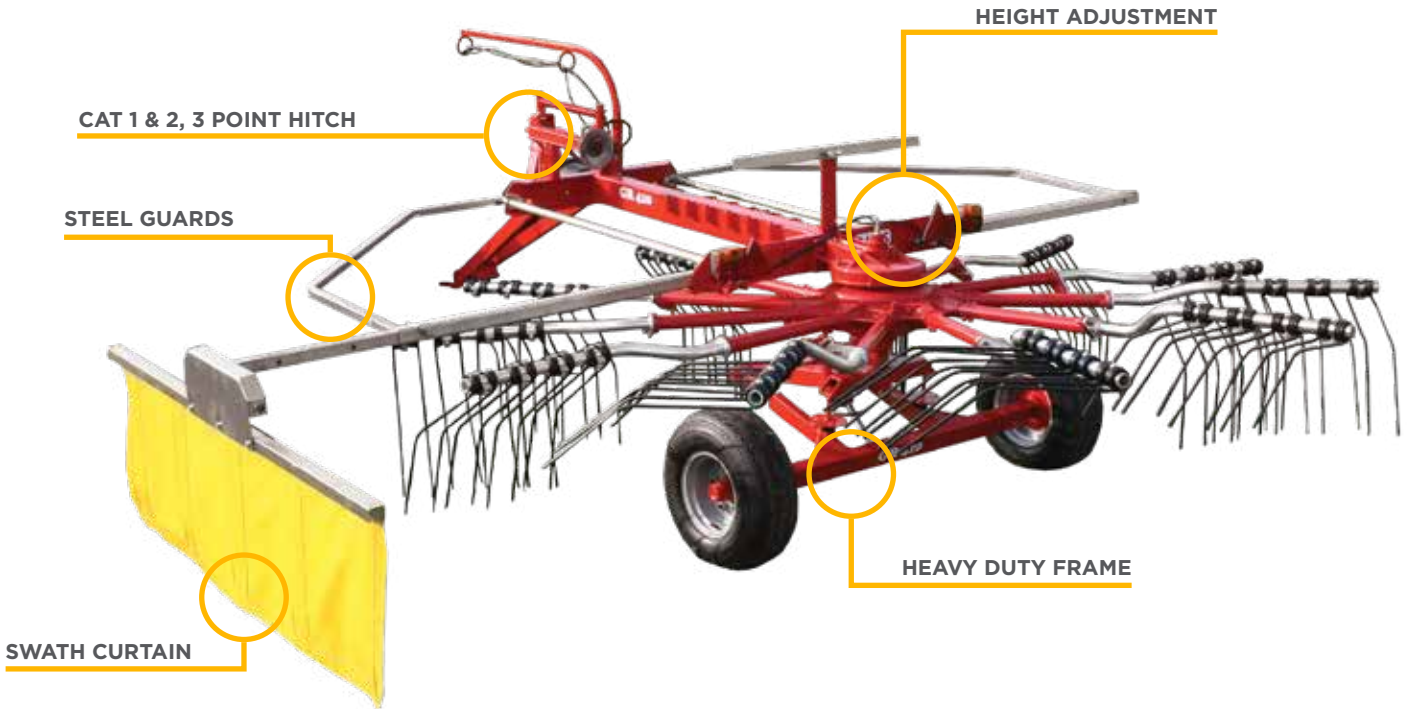

PART #	BE-GR410DRT
WEIGHT	836 LBS
WORKING WIDTH	162"
TRANSPORT WIDTH	63"
HP RATING	30 HP
TANDEM	DUAL WHEEL
DOUBLE TEETH/ARM	3
ARMS	9
HITCH	TRAILED

**REPLACEMENT WEAR PARTS**

PART	PTO PART 1	PTO PART 2	TINES
PART #	69.888.002	611234005	45.000.220

**ROTARY TEDDERS & RAKES**



**MADE IN ITALY**  
**ROTARY TEDDER**

18'4"

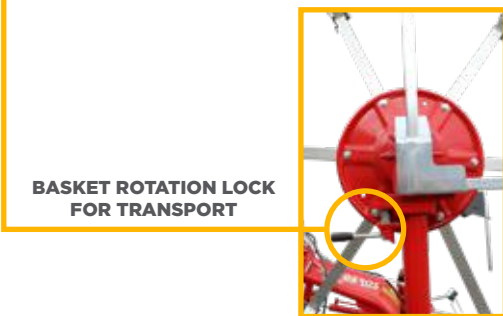

**BASKET ROTATION LOCK FOR TRANSPORT**



PART #	BE-GT560DR
WEIGHT	882 LBS
WIDTH	18'4"
WORKING WIDTH	17'9"
TRANSPORT WIDTH	8'3"
HP RATING	45 HP
BASKETS	4



**MINIMAL TRANSPORTATION FOOTPRINT POSSIBLE WITH 180° BASKET ROTATION**

**MADE IN POLAND**  
**3 POINT**  
**TEDDER/  
RAKE**  
**9'10"**



**540**  
RPM PTO

**RADIAL PIN**  
CLUTCH PTO

**SIMILAR TO**  
**HAYBOB**

**ADJUSTABLE**  
**SETTINGS**  
**FOR**  
**TEDDING**  
**& RAKING**

PART #	BE-TR300
WEIGHT	661 LBS
WIDTH	9'10"
HP RATING	24 HP
TANDEM	NO

**REPLACEMENT WEAR PARTS**

PART	TINES	SWATH TINES	RETURN SPRINGS
PART #	LH NARROW 45.000.107	45.000.114	LH 58.000.099
	LH WIDE 45.000.110		RH 58.000.100
	RH WIDE 45.000.111		
	RH NARROW 45.000.106		

**ROTARY TEDDERS & RAKES**

MADE IN POLAND

**3 PT**  
**TEDDER/RAKE**

WITH TANDEM WHEEL OPTION  
9'10"

PNEUMATIC TIRES  
15 X 6.00 - 6, 4 PLY

ADJUSTABLE SETTINGS  
FOR TEDDING AND RAKING

CAT 1 & 2,  
3 POINT HITCH

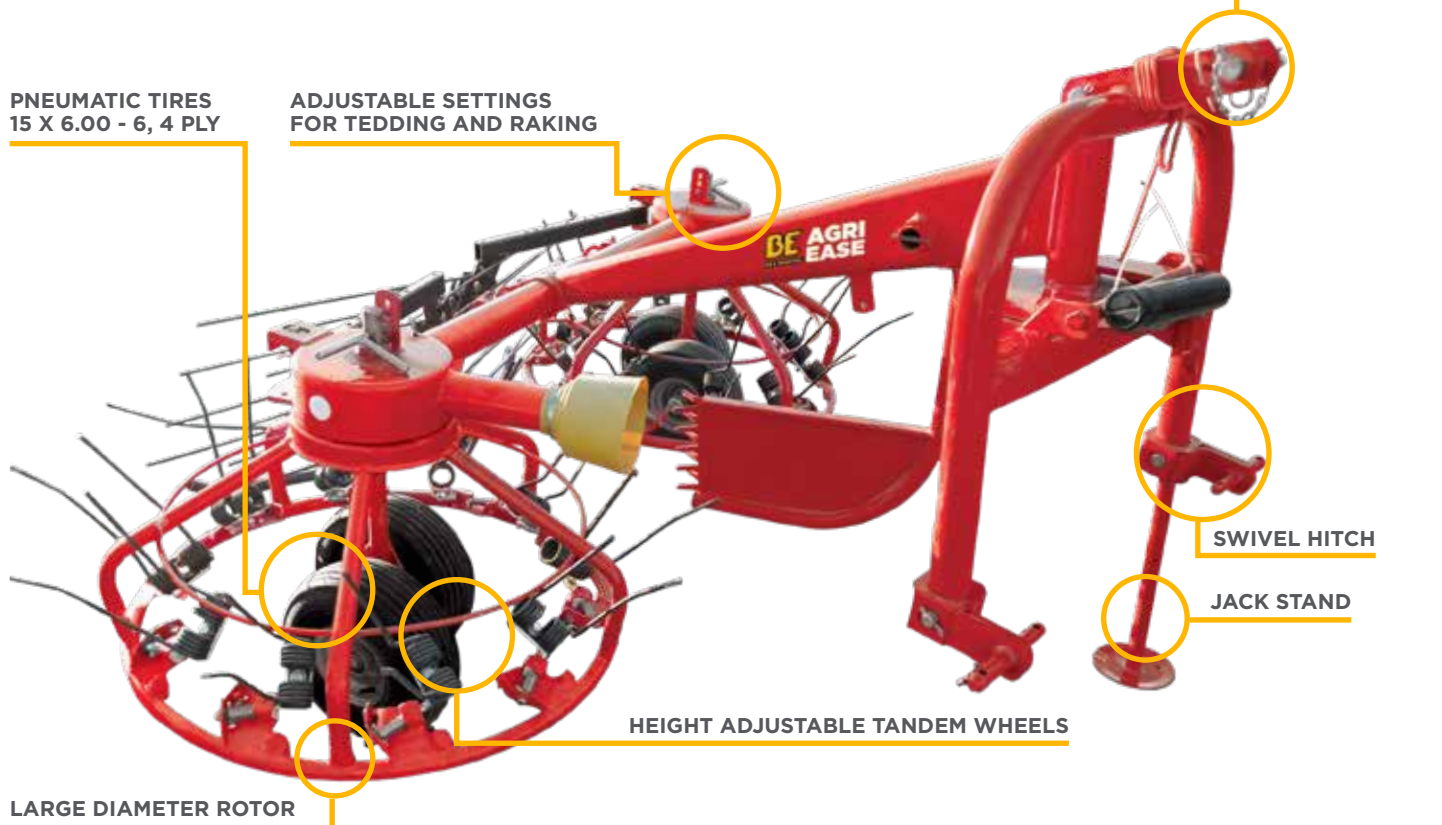

LARGE DIAMETER ROTOR

**540**  
RPM PTO

RADIAL PIN  
CLUTCH PTO

SIMILAR TO  
**HAYBOB**

ADJUSTABLE  
SETTINGS  
FOR  
TEDDING  
& RAKING

PART #	BE-TR300T
WEIGHT	680 LBS
WIDTH	9'10"
HP RATING	24 HP
TANDEM	DUAL WHEEL

**REPLACEMENT WEAR PARTS**

TINES	SWATH TINES	RETURN SPRINGS
LH NARROW 45.000.107	45.000.114	LH 58.000.099
LH WIDE 45.000.110		RH 58.000.100
RH WIDE 45.000.111		
RH NARROW 45.000.106		



**MADE IN ITALY**  
**SICKLE MOWER**  
4'9", 5'9", 6'8", 7'6"

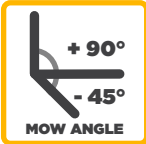
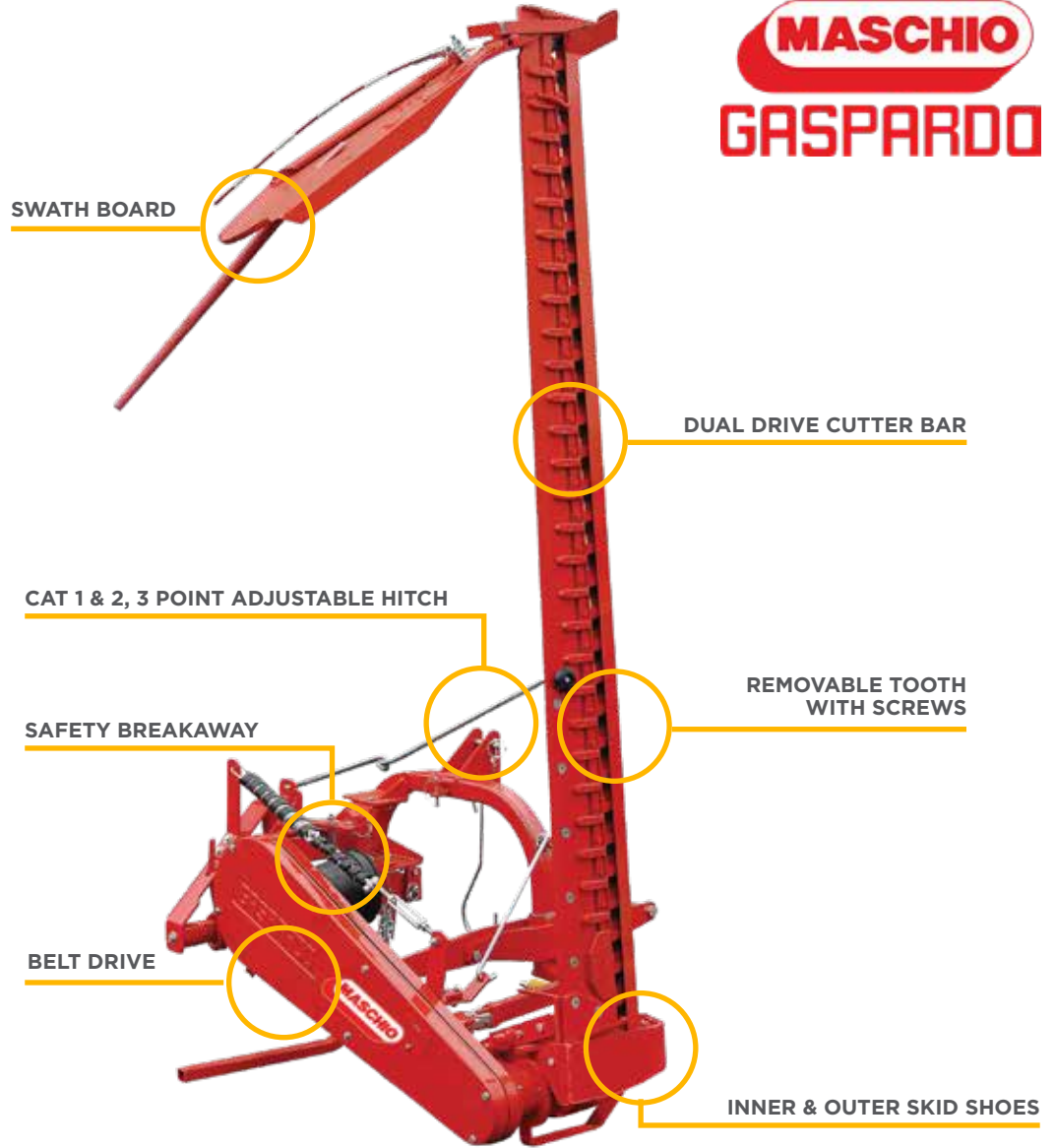

**INCLUDES 1 EXTRA SICKLE FREE!**

**1 HYDRAULIC PORT REQUIRED FOR HYDRAULIC MODELS**



PART #	GAS-FIORE145*	GAS-FIORE175*	GAS-FIORE175H**	GAS-FIORE205*	GAS-FIORE205H**	GAS-FIORE235H**
WEIGHT	490 LBS	507 LBS	507 LBS	525 LBS	525 LBS	542 LBS
CUTTING WIDTH	4'9"	5'9"	5'9"	6'8"	6'8"	7'6"
HP RATING	25 - 70 HP	25 - 70 HP	25 - 70 HP	25 - 70 HP	25 - 70 HP	25 - 70 HP
CUTTER BAR LIFT	MANUAL	MANUAL	HYDRAULIC	MANUAL	HYDRAULIC	HYDRAULIC
PORTS REQUIRED	0	0	1	0	1	1

\*MANUAL LIFT MODEL \*\*HYDRAULIC LIFT MODEL - REQUIRES 1 HYDRAULIC PORT

**REPLACEMENT WEAR PARTS FOR ALL UNITS**

PART	PTO	UPPER BLADE GUIDE	KNIFE	RIVETS
PART #	69.888.400	21120232	21120243	48974018

**OPTIONS**

PART #	GAS-99556001**
DESCRIPTION	HYDRAULIC CUTTING BAR LIFT KIT

\*\*REQUIRES 1 HYDRAULIC PORT



MADE IN POLAND

**DRUM  
MOWER**

65"

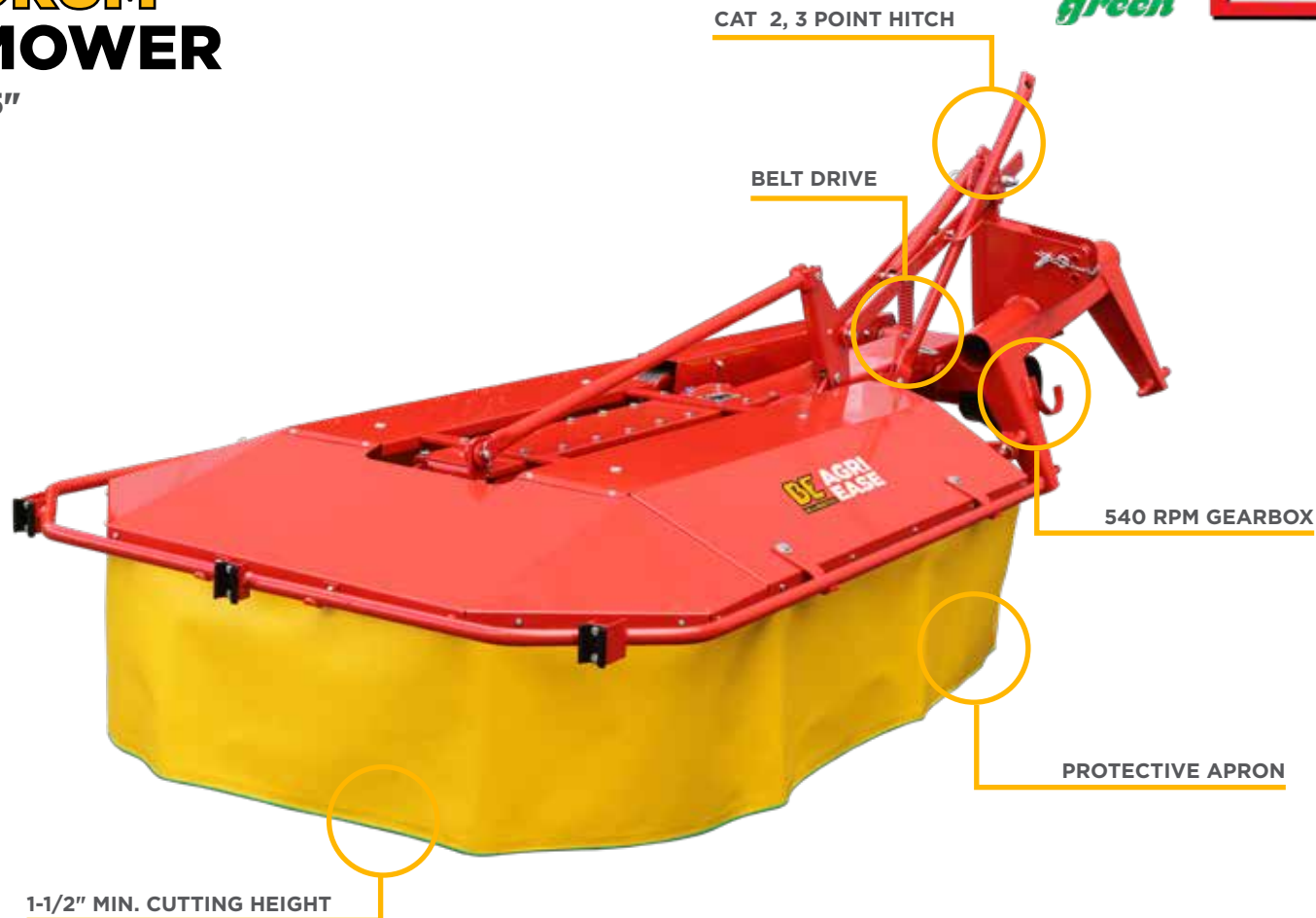

PART #	BE-Z175
WEIGHT	838 LBS
WORKING WIDTH	65"
HP RATING	MIN 30 HP
DRUMS	2
KNIVES	6
MIN MOWING HEIGHT	1.5"
ACRES/HR	5.4

**DEBRIS BURYING  
ROTARY TILLER**

57"

**NEW!**

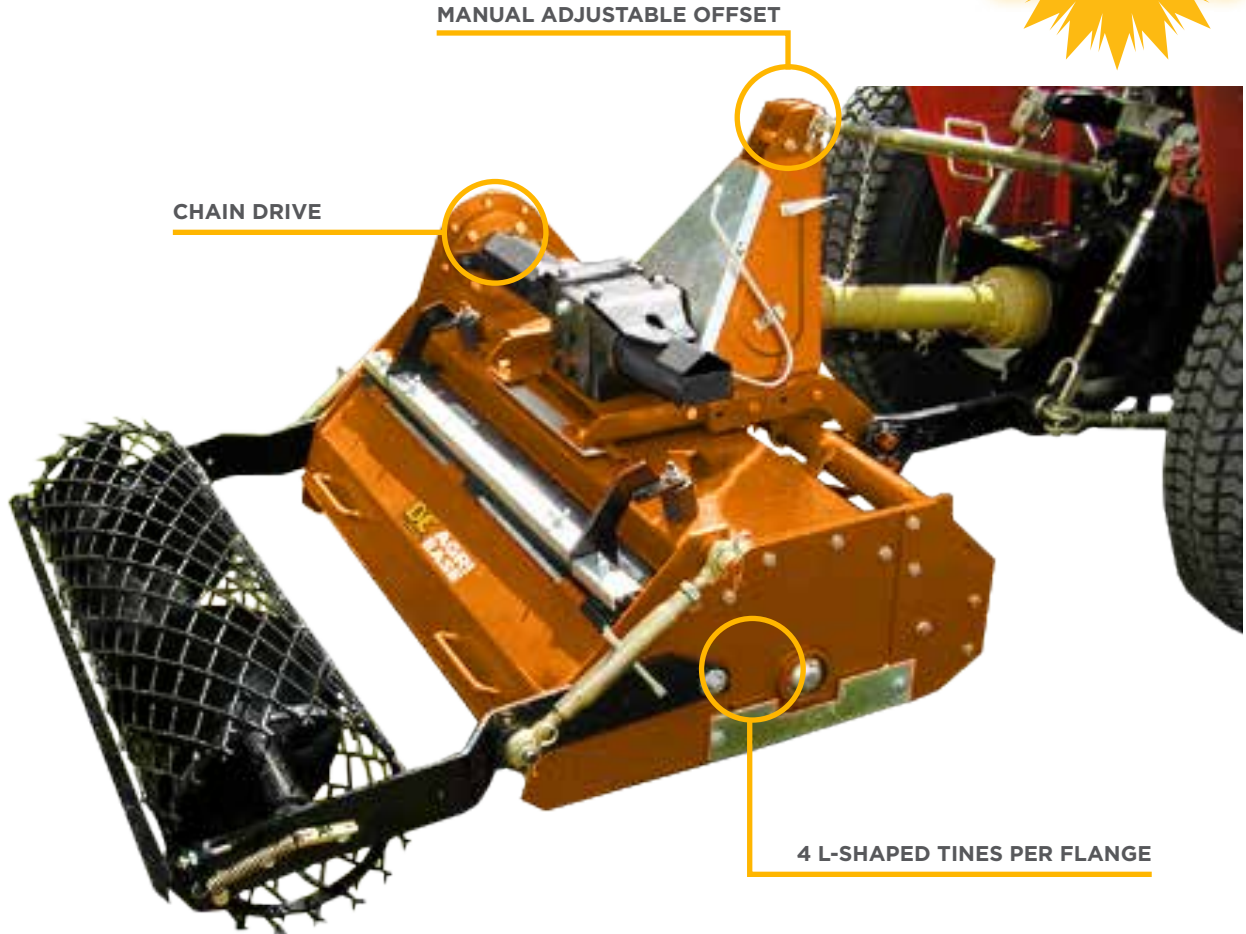

**SPECIALY  
DESIGNED TO  
BURY  
STONES**

**ROTOR SPINS IN  
REVERSE  
DIRECTION!**

PART #	BE-SB145R
WEIGHT	580 LBS
TILLING WIDTH	57"
HP RATING	25 - 40 HP
TILLAGE DEPTH	4.72"
BLADES	28

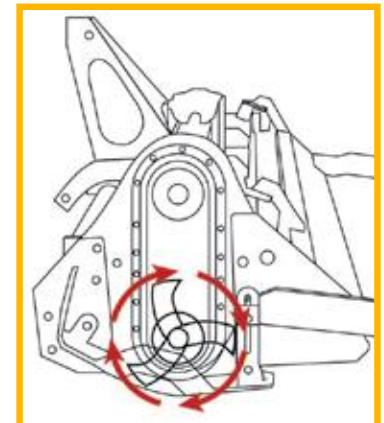

**ROTARY TILLERS**

**SUB COMPACT ROTARY TILLER**

33"

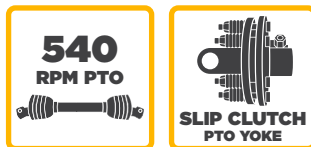

PART #	BE-TL85
WEIGHT	310 LBS
TILLING WIDTH	33"
TOTAL WIDTH	37"
HP RATING	12 - 40 HP
TILLAGE DEPTH	2"-6"
BLADES	16

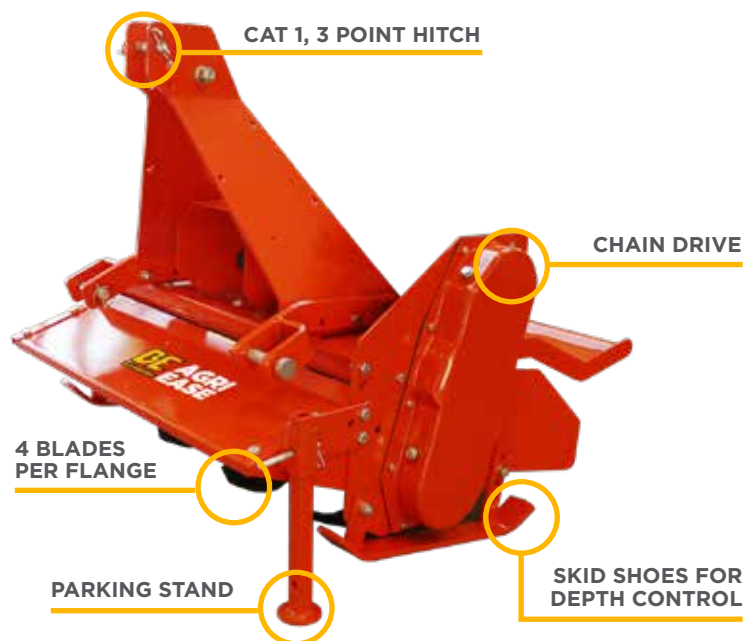

**ROTARY TILLER**

40"

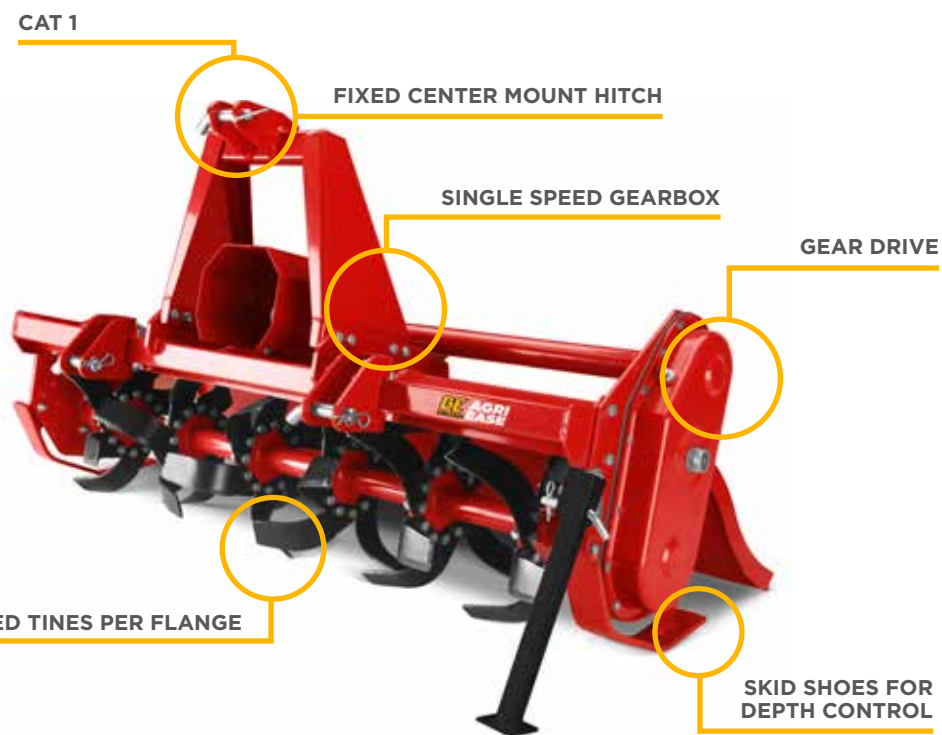

PART #	BE-TXG40
WEIGHT	304 LBS
TILLING WIDTH	40"
TOTAL WIDTH	44"
HP RATING	23 - 35 HP
TILLAGE DEPTH	6.5"
BLADES	24

**ROTARY TILLER**

47", 51", 59"



**FTL ROTARY TILLERS**

PART #	BE-FTL125	BE-FTL135	BE-FTL150
CATEGORY	1	1	1
WEIGHT	518 LBS	562 LBS	607 LBS
TILLING WIDTH	47"	51"	59"
HP RATING	15 - 30 HP	15 - 30 HP	15 - 30 HP
TILLAGE DEPTH	3.54"	3.54"	3.54"
BLADES	24	28	32

**REPLACEMENT WEAR PARTS FOR ALL UNITS**

PART	PTO	LEFT BLADE	RIGHT BLADE	BOLT KIT
PART #	69.888.400	63.000.067	63.000.066	05.000.006





**ROTARY  
TILLER**

47", 55", 63", 71", 79"



**TS ROTARY TILLERS**

PART #	BE-TS120	BE-TS140	BE-TS160	BE-TS180	BE-TS200
WEIGHT	475 LBS	538 LBS	602 LBS	643 LBS	731 LBS
TILLING WIDTH	47"	55"	63"	71"	79"
HP RATING	20 - 50 HP	20 - 50 HP	20 - 50 HP	20 - 50 HP	20 - 50 HP
TILLAGE DEPTH	6-1/2"	6-1/2"	6-1/2"	6-1/2"	6-1/2"
BLADES	36	42	48	54	60

**REPLACEMENT WEAR PARTS FOR ALL UNITS**

PART	PTO	LEFT BLADE	RIGHT BLADE	BOLT KIT
PART #	69.777.025	63.000.048	63.000.049	05.000.006



**ROTARY TILLERS**

**IGN  
ROTARY  
TILLER**

35", 59", 71"

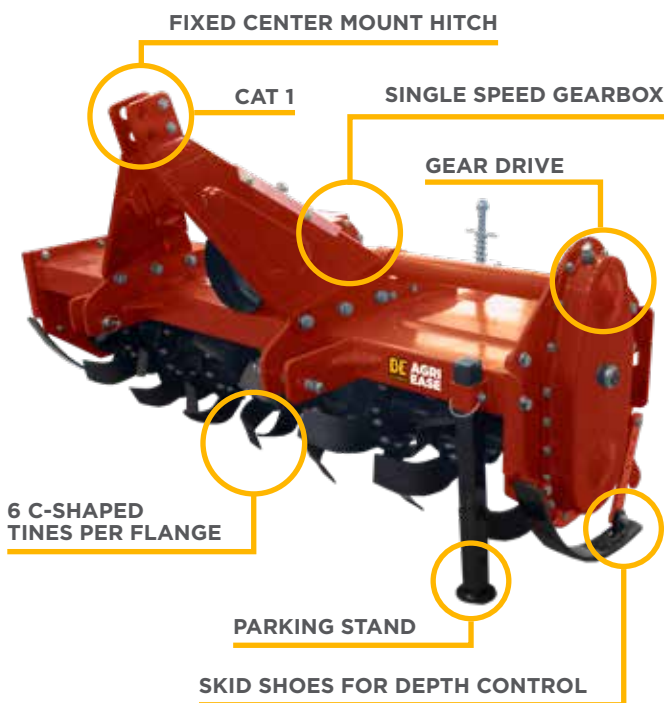

**IGN  
ROTARY  
TILLER**

82"

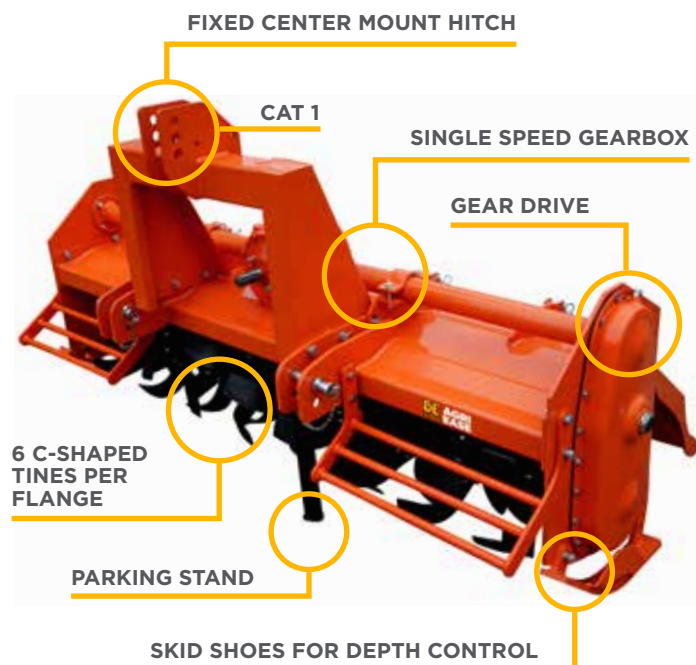

**IGN MEDIUM DUTY ROTARY TILLERS**

PART #	BE-IGN90	BE-IGN150	BE-IGN180	BE-IGN210
WEIGHT	550 LBS	705 LBS	782 LBS	1235 LBS
TILLING WIDTH	35"	59"	71"	82"
OVERALL WIDTH	44"	68"	80"	90"
HP RATING	16 - 20 HP	30 - 50 HP	30 - 50 HP	55 HP
TILLAGE DEPTH	4-3/4"	4-3/4"	4-3/4"	6.3"
BLADES	18	36	42	60

**REPLACEMENT WEAR PARTS FOR ALL UNITS**

PART	PTO	LEFT BLADE	RIGHT BLADE	BOLT KIT
PART #	69.777.025	63.000.019	63.000.020	05.000.002

**ROTARY TILLER**

49", 57", 65"

**NEW!**

WEEKEND *line*  
WARRIOR



CAT 1  
QUICK HITCH  
COMPATIBLE



ADJUSTABLE LINKAGES



OIL BATH  
LUBRICATION FOR  
ROTOR BEARINGS

4 C SHAPED TINES PER FLANGE

SINGLE SPEED  
HEAVY DUTY  
GEARBOX



CHAIN DRIVE



SKID SHOES FOR  
DEPTH CONTROL

PARKING STAND



**SD SERIES 49"-65" 15-40 HP**

**WEEKEND WARRIOR MEDIUM DUTY CENTER MOUNT FIXED HITCH ROTARY TILLERS**

PART #	MAS-SD4049	MAS-SD4057	MAS-SD4065
WEIGHT	487 LBS	602 LBS	715 LBS
WORKING DEPTH	7"	7"	7"
WORKING WIDTH	49"	57"	65"
TOTAL WIDTH	55"	63"	71"
HP RATING	15 - 40 HP	15 - 40 HP	15 - 40 HP

**REPLACEMENT WEAR PARTS FOR ALL UNITS**

PART	C RIGHT BLADE	C LEFT BLADE	BOLT KIT
PART #	63.000.068	63.000.069	05.000.006

**ROTARY TILLERS**

**ROTARY  
TILLER**

49", 62", 73"

**NEW!**

WEEKEND *line*  
WARRIOR



CAT 1  
QUICK HITCH  
COMPATIBLE



SINGLE SPEED  
HEAVY DUTY  
GEARBOX

ADJUSTABLE LINKAGES



OIL BATH  
LUBRICATION FOR  
ROTOR BEARINGS



QUICK HITCH  
COMPATIBLE



540  
RPM PTO



SLIP CLUTCH  
PTO YOKE

6 C SHAPED  
TINES PER FLANGE

GEAR DRIVE



SKID SHOES FOR  
DEPTH CONTROL

PARKING STAND

**HD SERIES 49"-73" 18-40 HP**

**WEEKEND WARRIOR HEAVY DUTY CENTER MOUNT FIXED HITCH ROTARY TILLERS**

PART #	MAS-HD6049	MAS-HD6062	MAS-HD6073
WEIGHT	540 LBS	672 LBS	747 LBS
WORKING DEPTH	8"	8"	8"
WORKING WIDTH	49"	62"	73"
TOTAL WIDTH	55"	68"	79"
HP RATING	18 - 60 HP	18 - 60 HP	20 - 60 HP

**REPLACEMENT WEAR PARTS FOR ALL UNITS**

PART	C RIGHT BLADE	C LEFT BLADE	BOLT KIT
PART #	63.000.068	63.000.069	05.000.006

**ROTARY TILLER**

42", 50", 58", 66"

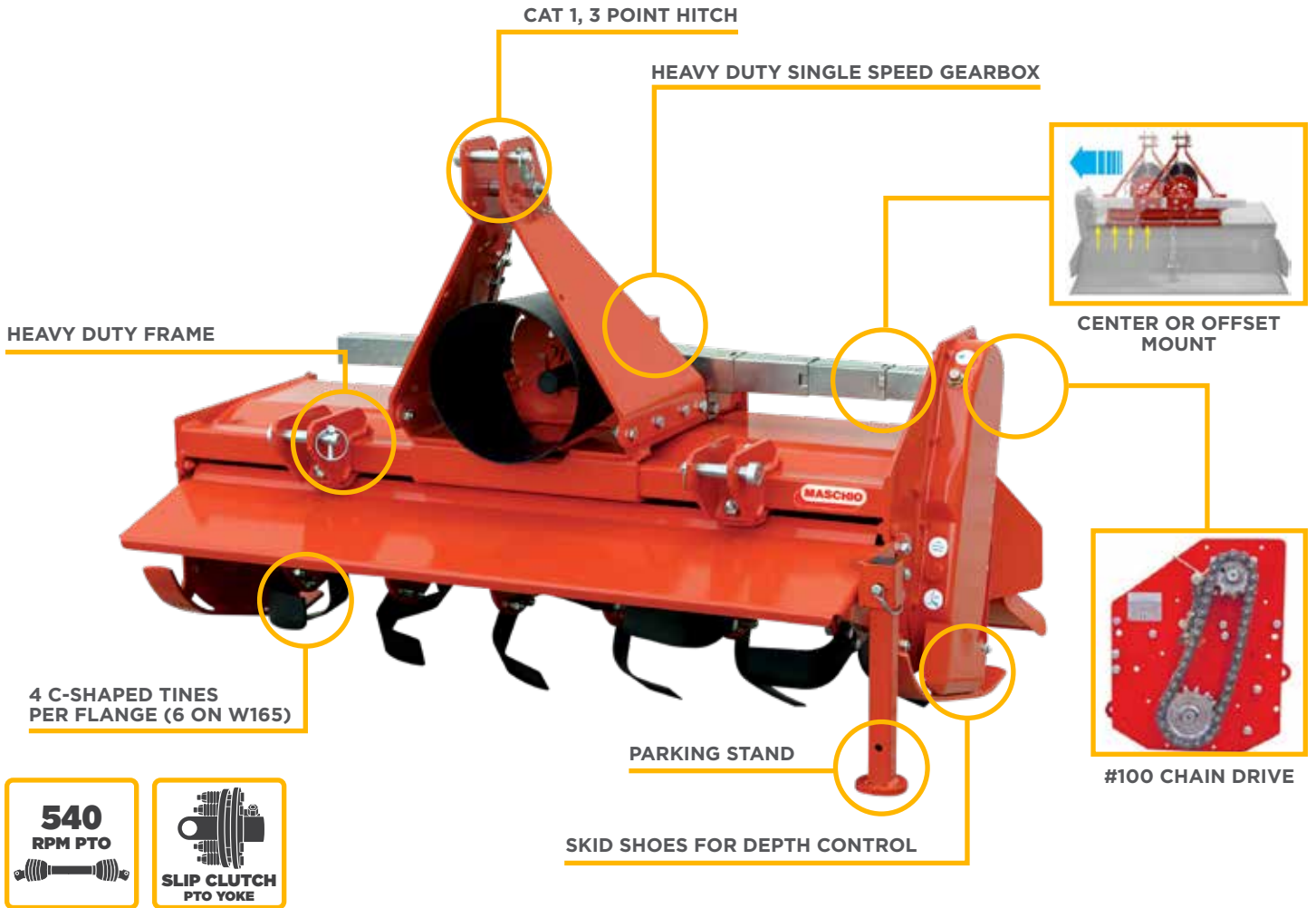

**W SERIES 42"-66" 13-40 HP**

**W SERIES WEEKENDER MEDIUM DUTY OFFSET ROTARY TILLERS**

PART #	MAS-W105	MAS-W125	MAS-W145	MAS-W165
WEIGHT	395 LBS	426 LBS	462 LBS	532 LBS
WORKING DEPTH	7"	7"	7"	7"
WORKING WIDTH	42"	50"	58"	66"
TOTAL WIDTH	47"	55"	63"	71"
HP RATING	15 - 25 HP	23 - 40 HP	25 - 40 HP	30 - 40 HP

**REPLACEMENT WEAR PARTS FOR ALL UNITS**

PART	C RIGHT BLADE	C LEFT BLADE	BOLT KIT
PART #	63.000.066	63.000.067	05.000.006





# ROTARY TILLER

42", 50", 58", 66", 72"

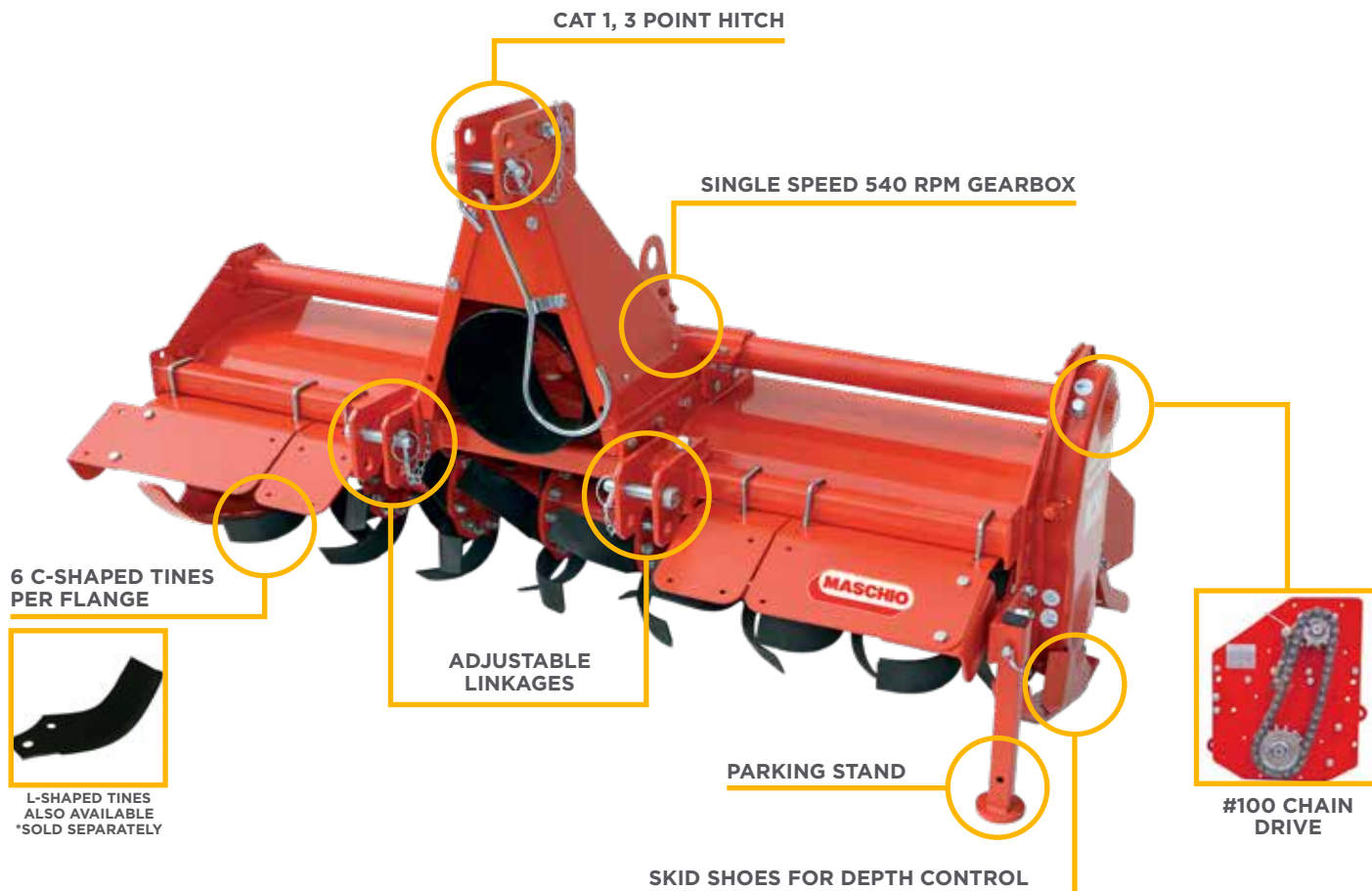

## A SERIES 42"-72" 15-60 HP

### A SERIES HEAVY DUTY COMMERCIAL WEEKENDER ROTARY TILLERS

PART #	MAS-A100	MAS-A120	MAS-A140	MAS-A160	MAS-A180
WEIGHT	503 LBS	543 LBS	593 LBS	660 LBS	715 LBS
WORKING DEPTH	8"	8"	8"	8"	8"
WORKING WIDTH	42"	50"	58"	66"	72"
TOTAL WIDTH	47"	55"	63"	71"	79"
HP RATING	20 - 60 HP	35 - 60 HP	40 - 60 HP	45 - 60 HP	45 - 60 HP

### REPLACEMENT WEAR PARTS FOR ALL UNITS

PART	L RIGHT BLADE	L LEFT BLADE	C RIGHT BLADE	C LEFT BLADE	BOLT KIT
PART #	63.000.046	63.000.047	63.000.048	63.000.049	05.000.006

**ROTARY  
TILLER**

50", 58", 66", 74", 82"

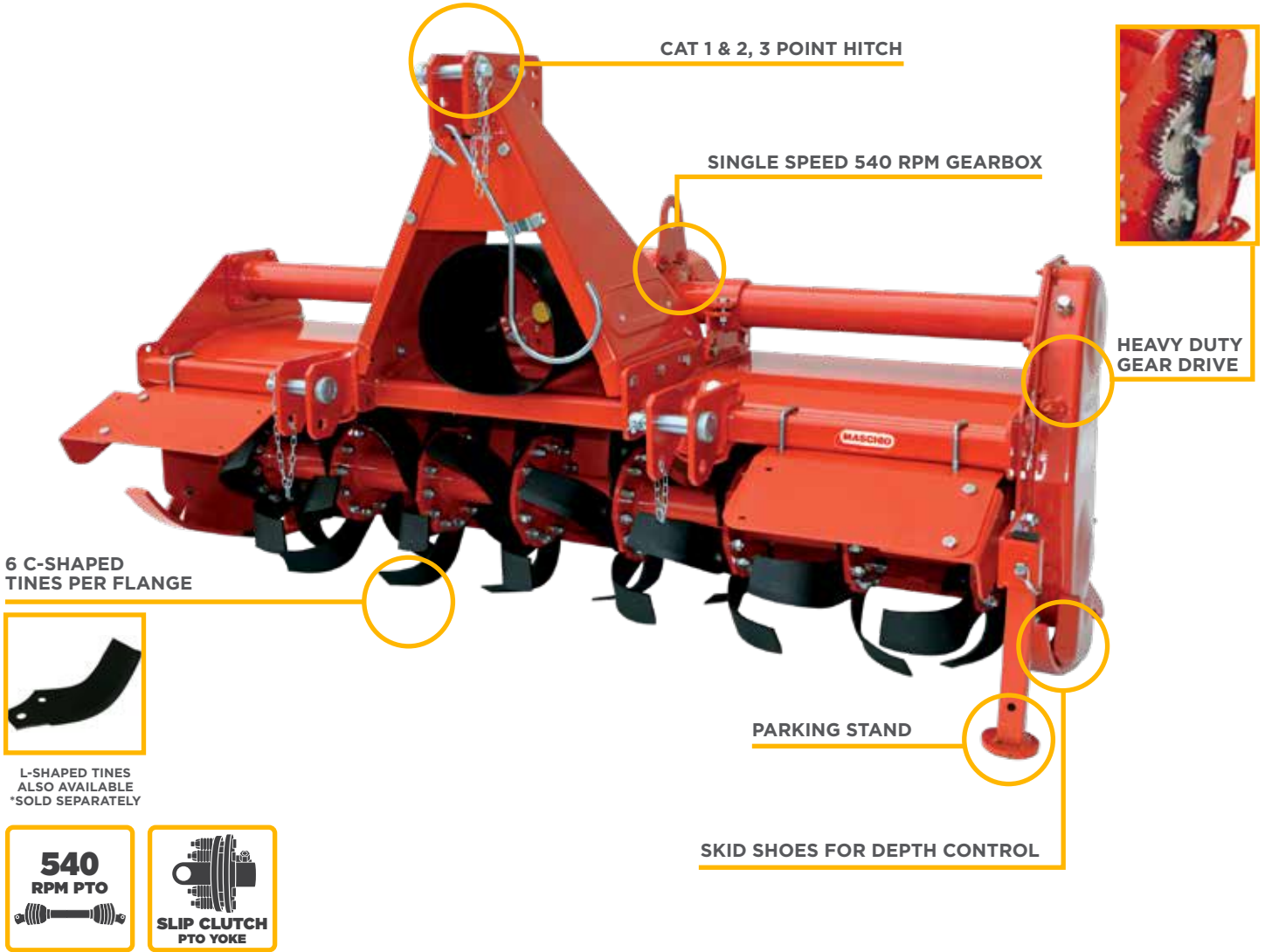

6 C-SHAPED  
TINES PER FLANGE



L-SHAPED TINES  
ALSO AVAILABLE  
\*SOLD SEPARATELY



**H SERIES 50"-82" 30-70 HP**

**H SERIES MEDIUM DUTY COMMERCIAL ROTARY TILLERS**

PART #	MAS-H125	MAS-H145	MAS-H165	MAS-H185	MAS-H205
WEIGHT	616 LBS	660 LBS	712 LBS	797 LBS	840 LBS
WORKING DEPTH	8-1/2"	8-1/2"	8-1/2"	8-1/2"	8-1/2"
WORKING WIDTH	50"	58"	66"	74"	82"
TOTAL WIDTH	55"	63"	71"	77"	87"
HP RATING	30 - 60 HP	35 - 70 HP	40 - 70 HP	45 - 70 HP	50 - 70 HP

**REPLACEMENT WEAR PARTS FOR ALL UNITS**

PART	L RIGHT BLADE	L LEFT BLADE	C RIGHT BLADE	C LEFT BLADE	BOLT KIT
PART #	63.000.046	63.000.047	63.000.048	63.000.049	05.000.006



**ROTARY TILLERS**



**ROTARY TILLER**

49", 57", 65", 73", 81"

**NEW!**

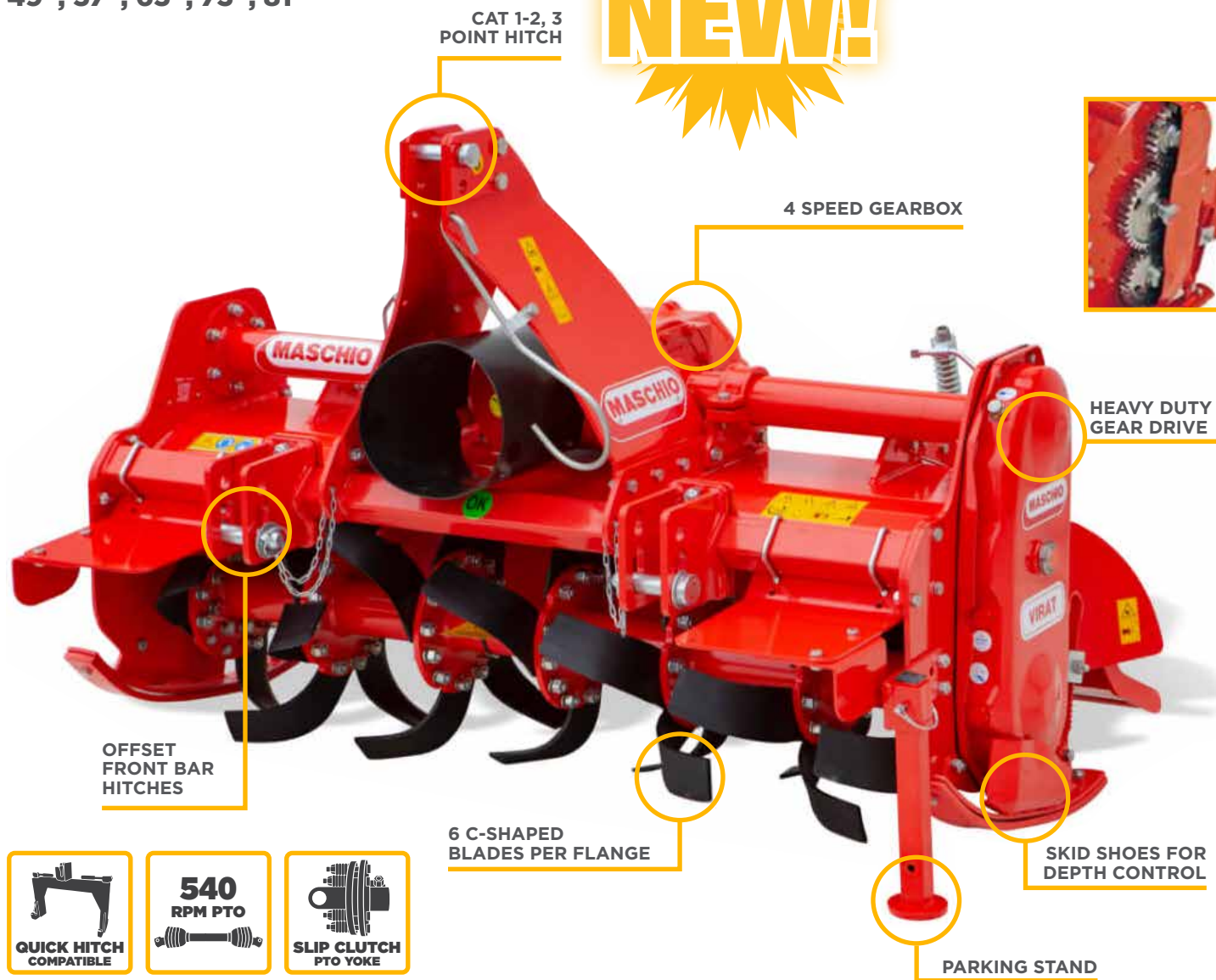



**QUICK HITCH  
COMPATIBLE**

**540  
RPM PTO**





**SLIP CLUTCH  
PTO YOKE**

**MULTI SPEED FIXED HITCH ROTARY TILLERS**

PART #	MAS-VIRAT125	MAS-VIRAT145	MAS-VIRAT165	MAS-VIRAT185	MAS-VIRAT205
WEIGHT	794 LBS	882 LBS	970 LBS	1036 LBS	1069 LBS
WORKING DEPTH	8.5"	8.5"	8.5"	8.5"	8.5"
WORKING WIDTH	49"	57"	65"	73"	81"
TOTAL WIDTH	55"	63"	71"	79"	91"
HP RATING	40 - 80 HP	40 - 80 HP	45 - 80 HP	50 - 80 HP	55 - 80 HP
BLADES	30	36	42	42	48

**REPLACEMENT WEAR PARTS FOR ALL UNITS**

PART	C RIGHT BLADE	C LEFT BLADE	BOLT KIT
PART #	63.000.063	63.000.062	05.000.007

**ROTARY TILLER**

54", 63", 73", 83"

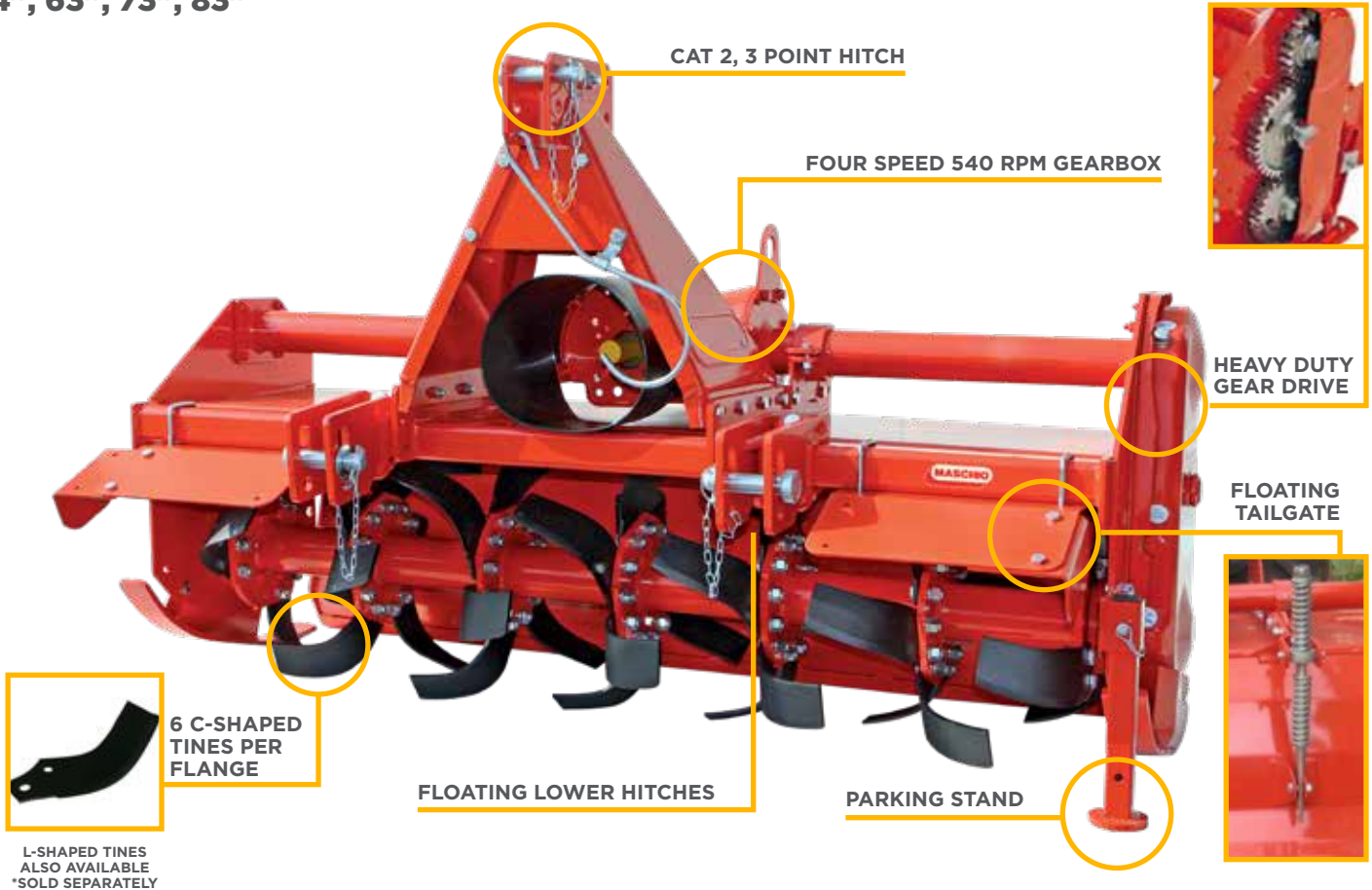

6 C-SHAPED TINES PER FLANGE

L-SHAPED TINES ALSO AVAILABLE \*SOLD SEPARATELY



**U SERIES 54"-80" 35-80 HP**

**U SERIES HEAVY DUTY COMMERCIAL UTILITY TILLERS**

PART #	MAS-U130	MAS-U155	MAS-U180	MAS-U205
WEIGHT	844 LBS	933 LBS	1022 LBS	1110 LBS
TILLING WIDTH	54"	63"	73"	83"
TOTAL WIDTH	58"	68"	78"	88"
HP RATING	35 - 80 HP	45 - 80 HP	50 - 80 HP	60 - 80 HP
WORKING DEPTH	9"	9"	9"	9"
BLADES	30	36	42	48

**REPLACEMENT WEAR PARTS FOR ALL UNITS**

PART	C LEFT BLADE	C RIGHT BLADE	L LEFT BLADE	L RIGHT BLADE	BOLT KIT
PART #	63.000.062	63.000.063	63.000.064	63.000.065	05.000.007

**ROTARY TILLERS**



**ROTARY  
TILLER**

63", 73", 83", 93"

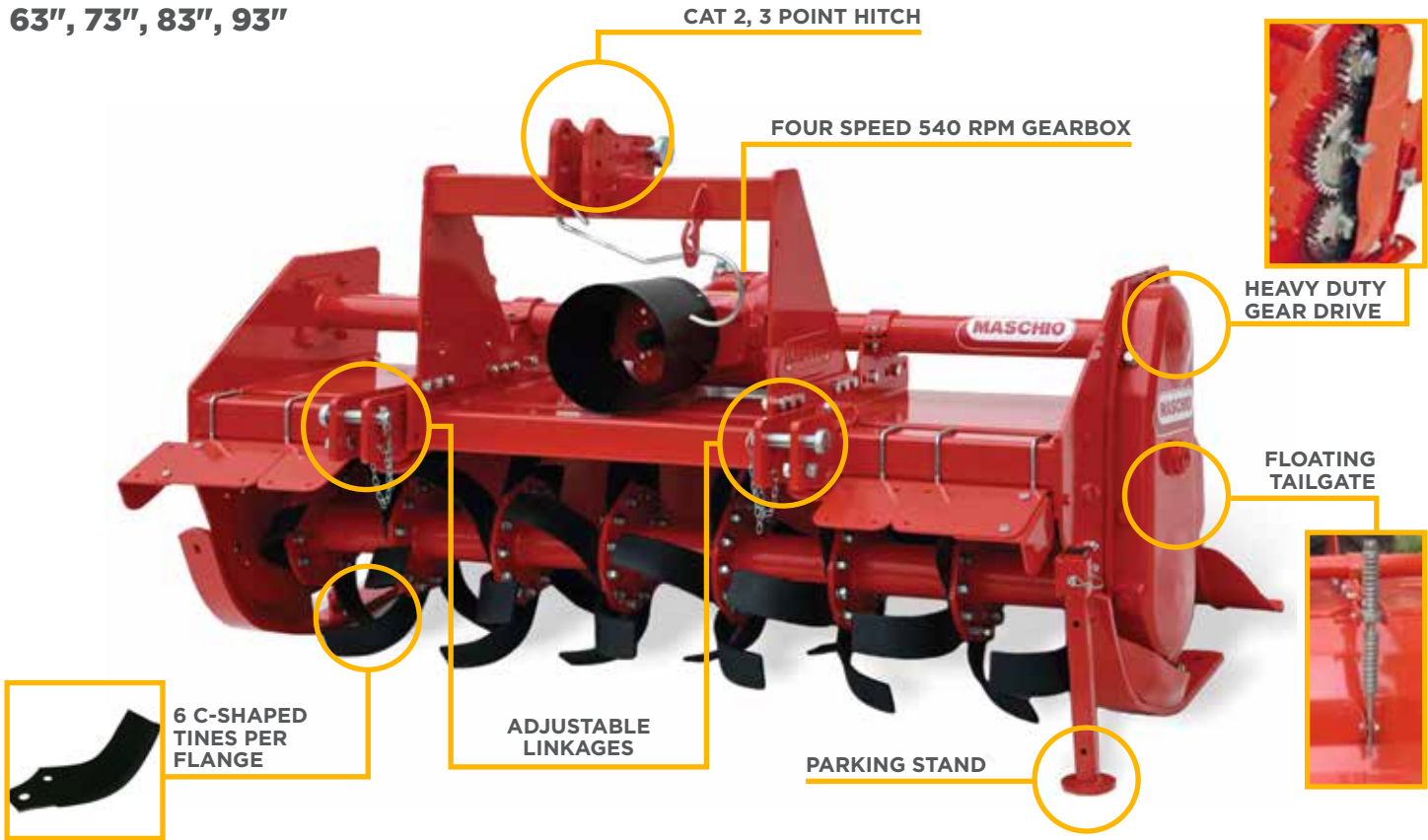

L-SHAPED TINES  
ALSO AVAILABLE  
\*SOLD SEPARATELY



**B SERIES 63"-93" 45-100 HP**

**B SERIES MEDIUM-HEAVY DUTY FARM UTILITY TILLERS**

PART #	MAS-B155	MAS-B155WR*	MAS-B180	MAS-B180WR*	MAS-B205	MAS-B205WR*	MAS-B230	MAS-B230WR*
WEIGHT	1206 LBS	1420 LBS	1356 LBS	1799 LBS	1523 LBS	1990 LBS	1654 LBS	2169 LBS
TILLING WIDTH	63"	63"	73"	73"	83"	83"	93"	93"
TOTAL WIDTH	68"	68"	78"	78"	88"	88"	98"	98"
HP RATING	45 - 100 HP	45 - 100 HP	50 - 100 HP	50 - 100 HP	60 - 100 HP	60 - 100 HP	70 - 100 HP	70 - 100 HP
WORKING DEPTH	11"	11"	11"	11"	11"	11"	11"	11"
BLADES	36	36	42	42	48	48	54	54

**REPLACEMENT WEAR PARTS FOR ALL UNITS**

PART	L RIGHT BLADE	L LEFT BLADE	C RIGHT BLADE	C LEFT BLADE	BOLT KIT
PART #	63.000.040**	63.000.041**	63.000.038**	63.000.039**	05.000.007

\*WR ADDED ROLLER - CAGE ROLLER

\*\*ADD H FOR "HEAVY" OPTION OR HS FOR "HARD SURFACE" OPTION



**ROTARY  
TILLER**

82", 93", 102", 122"

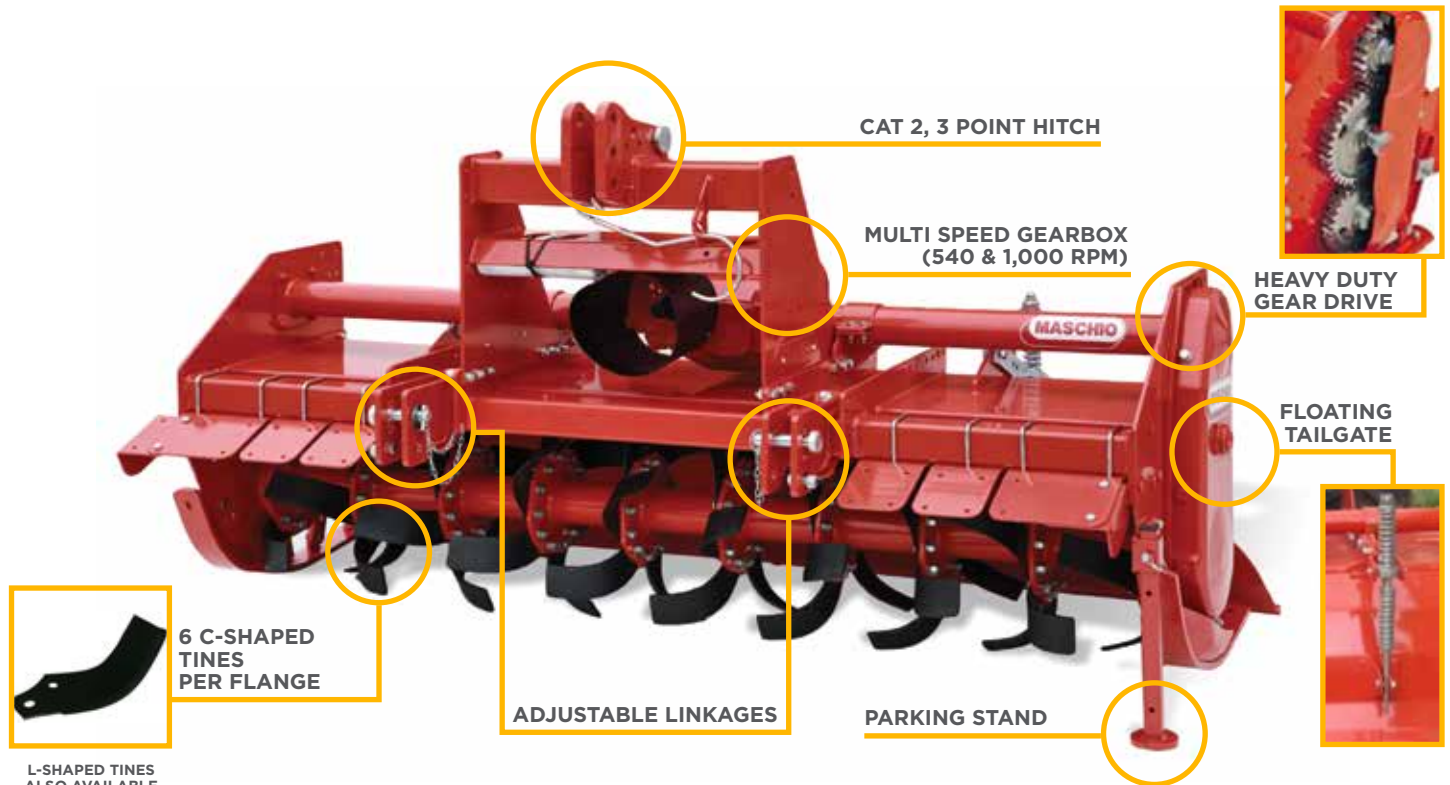

**C SERIES 82"-122" 50-130 HP**

**C SERIES HEAVY DUTY FARM UTILITY TILLERS**

PART #	MAS-C205	MAS-C205WR*	MAS-C230	MAS-C230WR*	MAS-C250	MAS-C250WR*	MAS-C300	MAS-C300WR*
WEIGHT	1562 LBS	1738 LBS	1672 LBS	1870 LBS	1780 LBS	2022 LBS	1958 LBS	2332 LBS
TILLING WIDTH	82"	82"	93"	93"	102"	102"	122"	122"
TOTAL WIDTH	88"	88"	98"	98"	108"	108"	127"	127"
HP RATING	60 - 130 HP	60 - 130 HP	70 - 130 HP	70 - 130 HP	80 - 130 HP	80 - 130 HP	100 - 130 HP	100 - 130 HP
WORKING DEPTH	11"	11"	11"	11"	11"	11"	11"	11"
BLADES	48	48	54	54	60	60	72	72

**REPLACEMENT WEAR PARTS FOR ALL UNITS**

PART	L RIGHT BLADE	L LEFT BLADE	C RIGHT BLADE	C LEFT BLADE	BOLT KIT
PART #	63.000.040**	63.000.041**	63.000.038**	63.000.039**	05.000.007

\*WR ADDED ROLLER - CAGE ROLLER

\*\*ADD H FOR "HEAVY" OPTION OR HS FOR "HARD SURFACE" OPTION

**ROTARY TILLERS**



**MADE IN ITALY**  
**ROTARY TILLER**

93", 102", 122", 150"

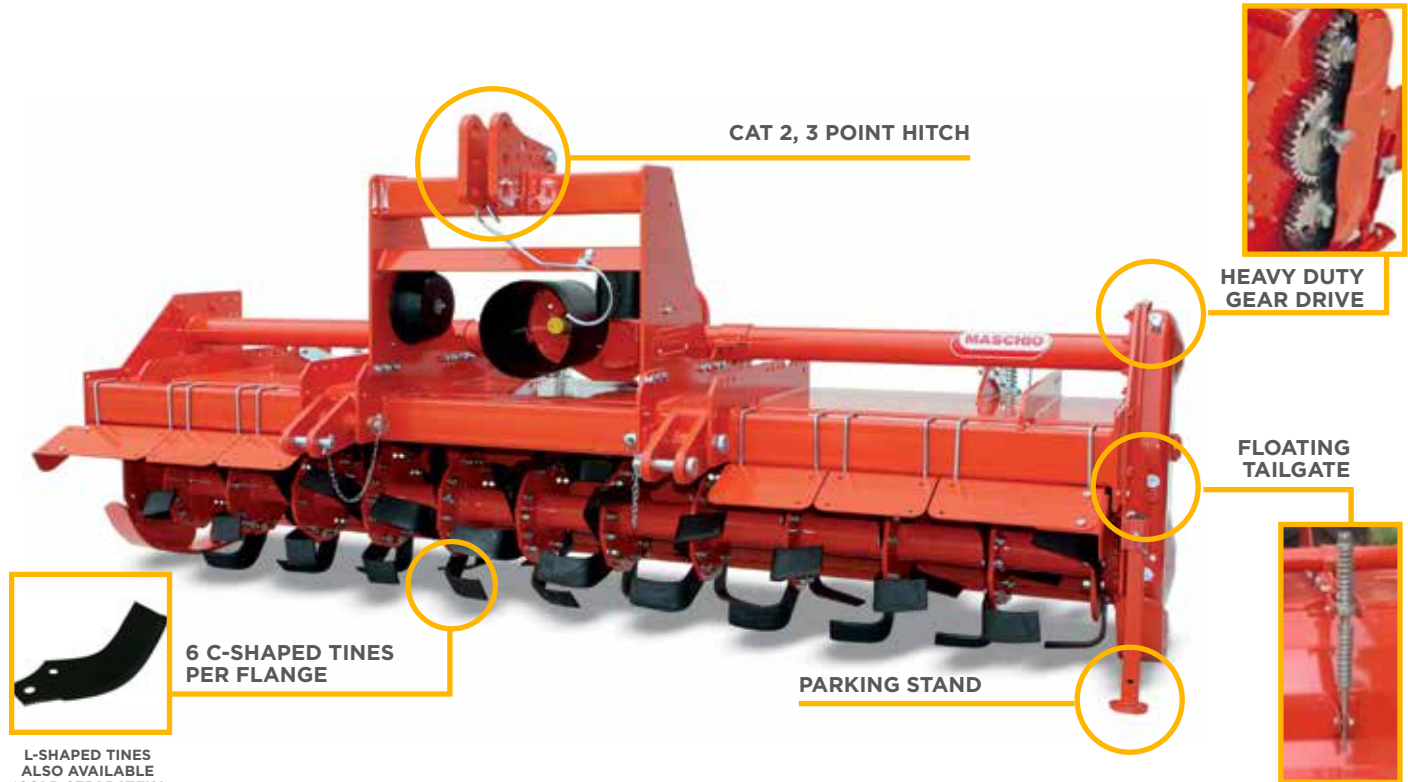

6 C-SHAPED TINES PER FLANGE

L-SHAPED TINES ALSO AVAILABLE \*SOLD SEPARATELY



**SC SERIES 93"-150" 90-170 HP**

**SC SERIES SUPER HEAVY DUTY ROTARY TILLERS**

PART #	MAS-SC230WR*	MAS-SC250	MAS-SC250WR*	MAS-SC300	MAS-SC300WR*	MAS-SC380	MAS-SC380WR*
WEIGHT	2458 LBS	2115 LBS	2660 LBS	2425 LBS	3022 LBS	3120 LBS	3880 LBS
TILLING WIDTH	93"	102"	102"	122"	122"	150"	150"
TOTAL WIDTH	98"	108"	108"	127"	127"	155"	155"
HP RATING	90 - 170 HP	100 - 170 HP	100 - 170 HP	130 - 170 HP	130 - 170 HP	150 - 170 HP	150 - 170 HP
WORKING DEPTH	11"	11"	11"	11"	11"	11"	11"
BLADES	54	60	60	72	72	90	90

**REPLACEMENT WEAR PARTS FOR ALL UNITS**

PART	L RIGHT BLADE	L LEFT BLADE	C RIGHT BLADE	C LEFT BLADE	BOLT KIT
PART #	63.000.040**	63.000.041**	63.000.038**	63.000.039**	05.000.007

\*WR ADDED ROLLER - CAGE ROLLER

\*\*ADD H FOR "HEAVY" OPTION OR HS FOR "HARD SURFACE" OPTION



 **MADE IN ITALY**

# DOUBLE TRANSMISSION ROTARY TILLER

**DUAL DRIVE UNIT - 167"**

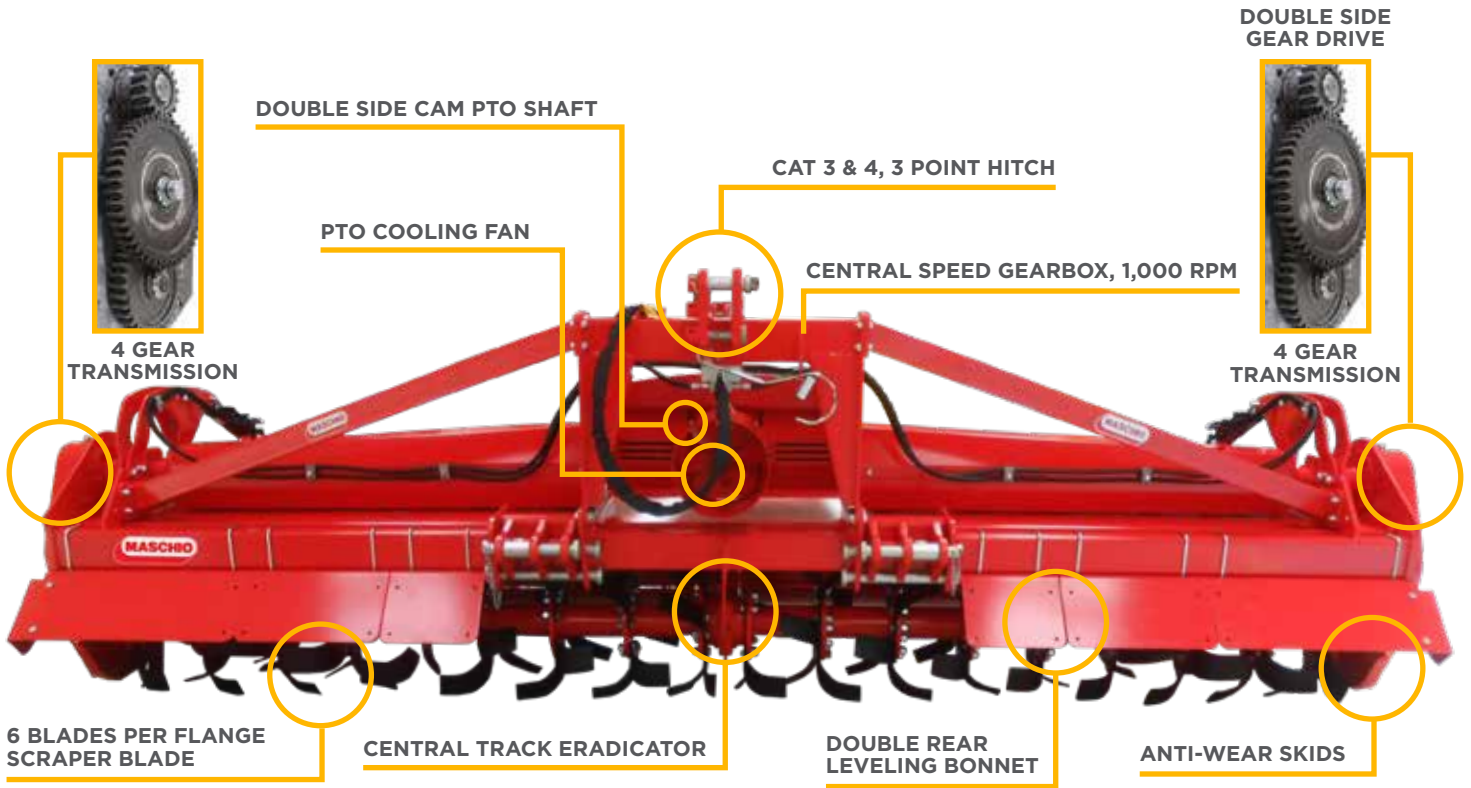

**G SERIES 167" 200-320 HP**

**G SERIES SUPER HEAVY DUTY DUAL DRIVE ROTARY TILLER**

PART #	MAS-G420WR*
WEIGHT	5357 LBS
TILLING WIDTH	167"
TOTAL WIDTH	181"
HP RATING	200 - 320 HP
WORKING DEPTH	10-5/8"
BLADES	96

**REPLACEMENT WEAR PARTS FOR ALL UNITS**

PART	C LEFT BLADE	C RIGHT BLADE	L RIGHT BLADE	L LEFT BLADE	BOLT KIT
PART #	63.000.050**	63.000.051**	63.000.052	63.000.053	05.000.009

\*WR ADDED ROLLER - CAGE ROLLER

\*\*ADD H FOR "HEAVY" OPTION OR HS FOR "HARD SURFACE" OPTION

**ROTARY TILLERS**



**MADE IN ITALY**  
**ROTARY TILLER**

189", 208", 228", 248"

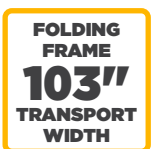
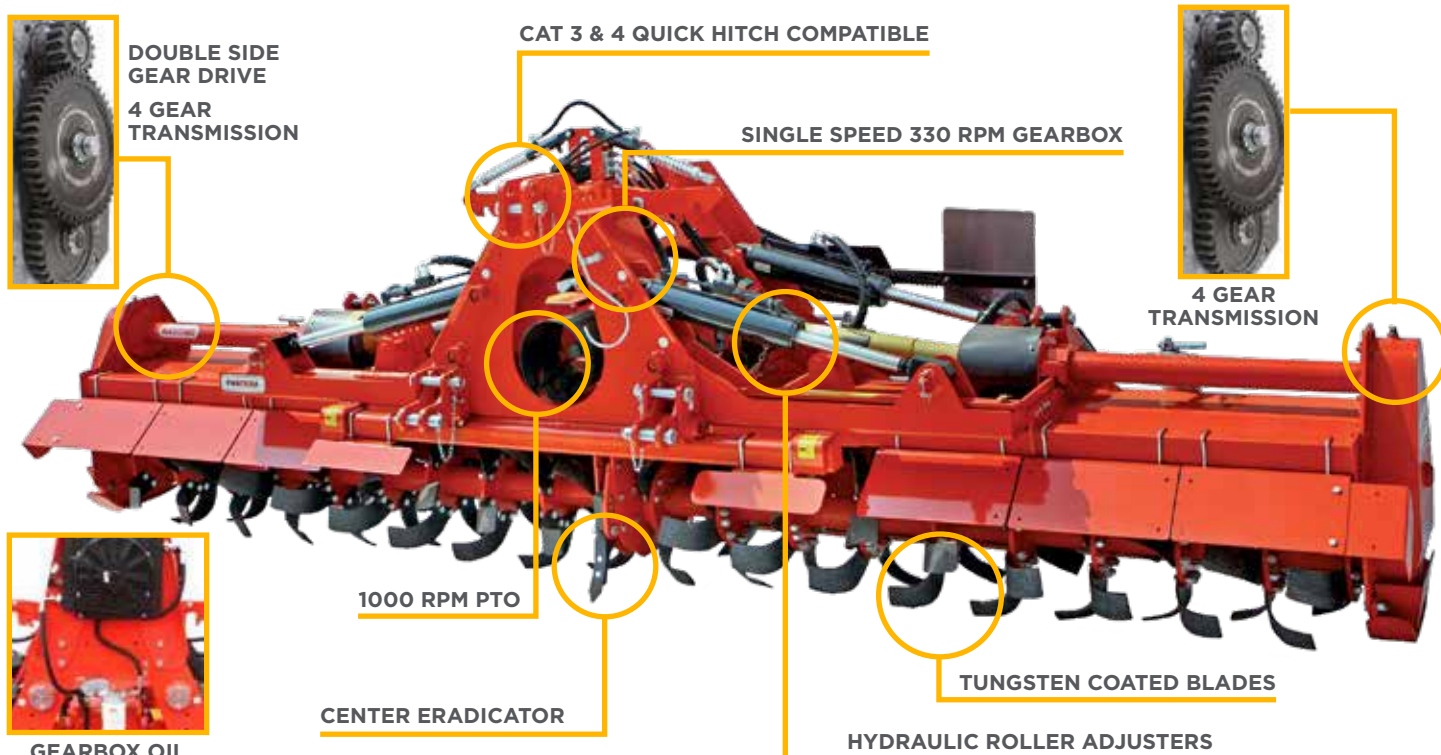

**PANTERA 189"-248" 220-380 HP**

**PANTERA SUPER HEAVY DUTY HYDRAULIC FOLD ROTARY TILLER**

PART #	MAS-PAN470WR*	MAS-PAN520WR*	MAS-PAN570WR*	MAS-PAN620WR*
WEIGHT	7660 LBS	8200 LBS	8740 LBS	9360 LBS
TILLING WIDTH	189"	208"	228"	248"
TOTAL WIDTH	200"	220"	240"	260"
HP RATING	220 - 380 HP	240 - 380 HP	260 - 380 HP	280 - 380 HP
KW RATING	160-280	176-280	190-280	205-280
WORKING DEPTH	12"	12"	12"	12"
BLADES	108	120	132	144
CENTER SPECS	94"	104"	114"	124"

**REPLACEMENT WEAR PARTS FOR ALL UNITS**

PART	C RIGHT BLADE	C LEFT BLADE	BOLT KIT
PART #	63.000.414	63.000.415	05.000.008

**MADE IN ITALY**  
**POWER HARROW**

52", 60", 71", 79"

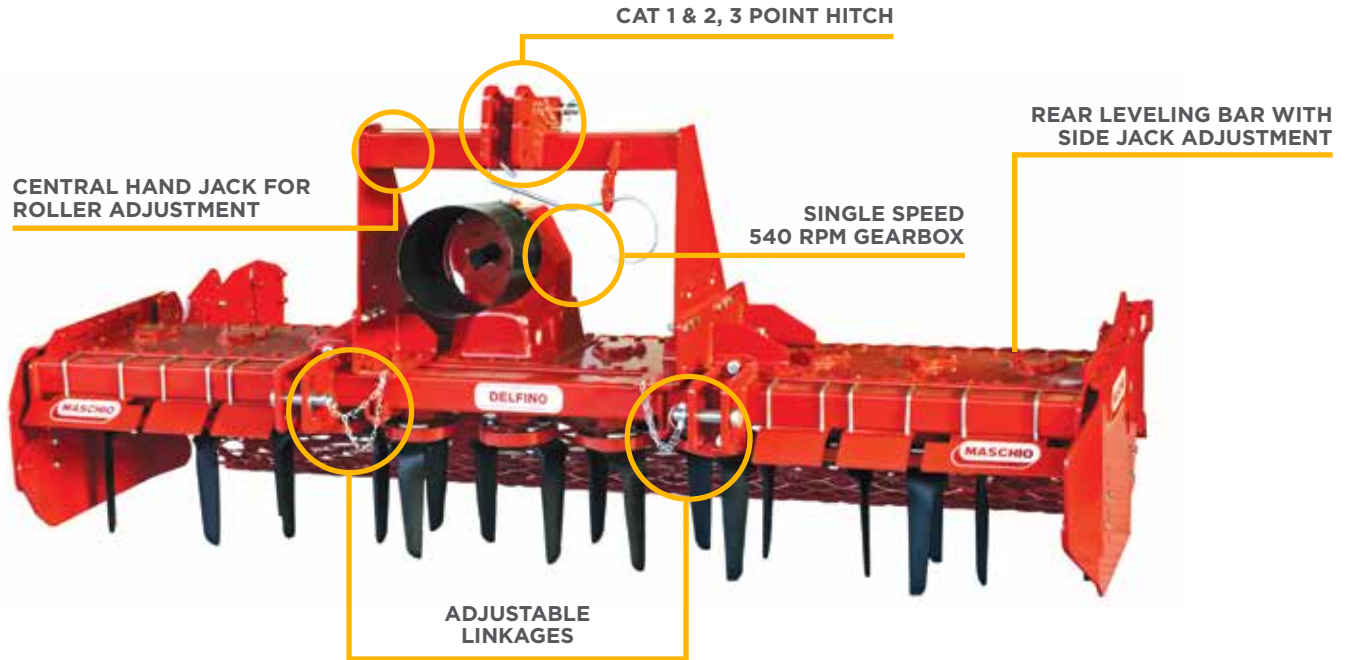

**DL SERIES 52"-79" 30-100 HP**

**DL SERIES POWER HARROW**

PART #	MAS-DLV1300WR*	MAS-DL1500WR*	MAS-DL1800WR*	MAS-DL2000WR*
WEIGHT	1010 LBS	1129 LBS	1166 LBS	1202 LBS
TILLING WIDTH	52"	60"	71"	79"
TOTAL WIDTH	54"	62"	73"	81"
HP RATING	30 - 100 HP	35 - 100 HP	45 - 100 HP	60 - 100 HP
KW RATING	22-74	26-74	33-74	44-74
WORKING DEPTH	11"	11"	11"	11"
BLADES	10	12	14	16
CENTER SPECS	26"	30"	36"	40"

**REPLACEMENT WEAR PARTS FOR ALL UNITS**

PART	CCW BLADE	CW BLADE	BOLT KIT
PART #	63.000.060	63.000.061	04.016.050

**ROTARY TILLERS**



**MADE IN ITALY**  
**POWER HARROW**  
60", 71", 79"

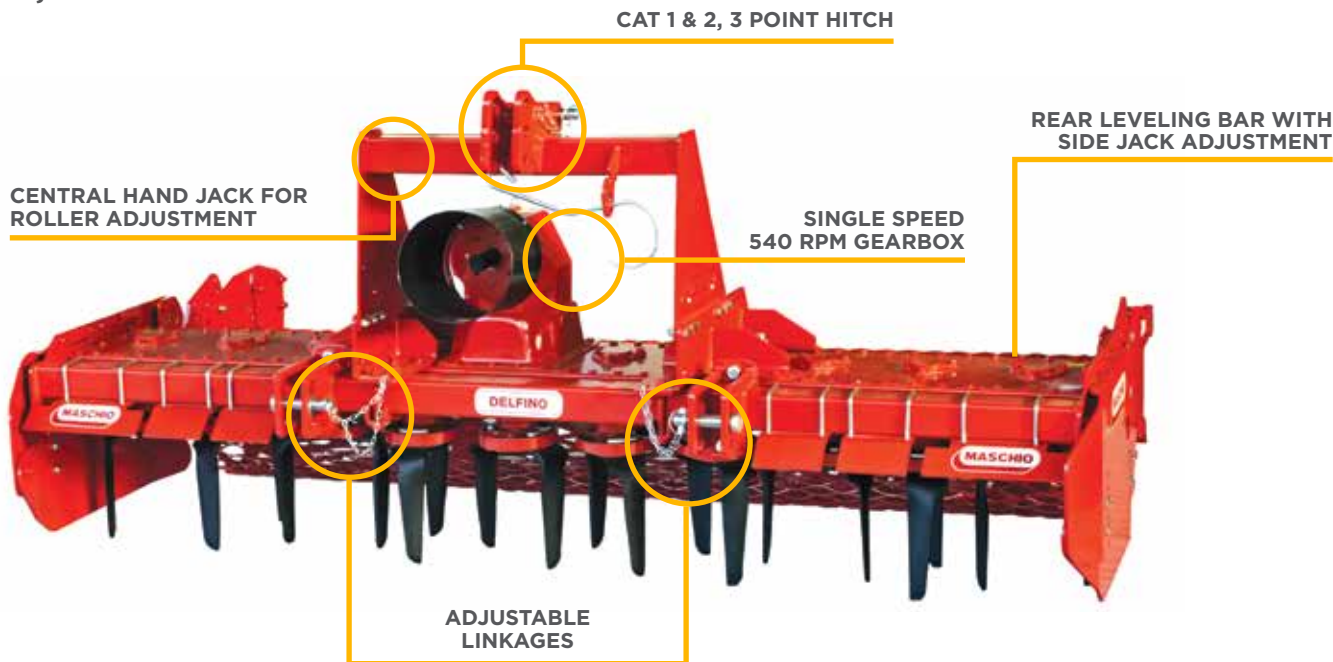

**DL SERIES 60"-79" 35-100 HP**

**DL SERIES POWER HARROW**

PART #	MAS-DL1500PR**	MAS-DL1800PR**	MAS-DL2000PR**
WEIGHT	1402 LBS	1413 LBS	1698 LBS
TILLING WIDTH	60"	71"	79"
TOTAL WIDTH	62"	73"	81"
HP RATING	35 - 100 HP	45 - 100 HP	60 - 100 HP
KW RATING	26-74	33-74	44-74
WORKING DEPTH	11"	11"	11"
BLADES	12	14	16
CENTER SPECS	30"	36"	40"

**REPLACEMENT WEAR PARTS FOR ALL UNITS**

PART	CCW BLADE	CW BLADE	BOLT KIT
PART #	63.000.060	63.000.061	04.016.050



**MADE IN ITALY**  
**POWER HARROW**  
99", 119"

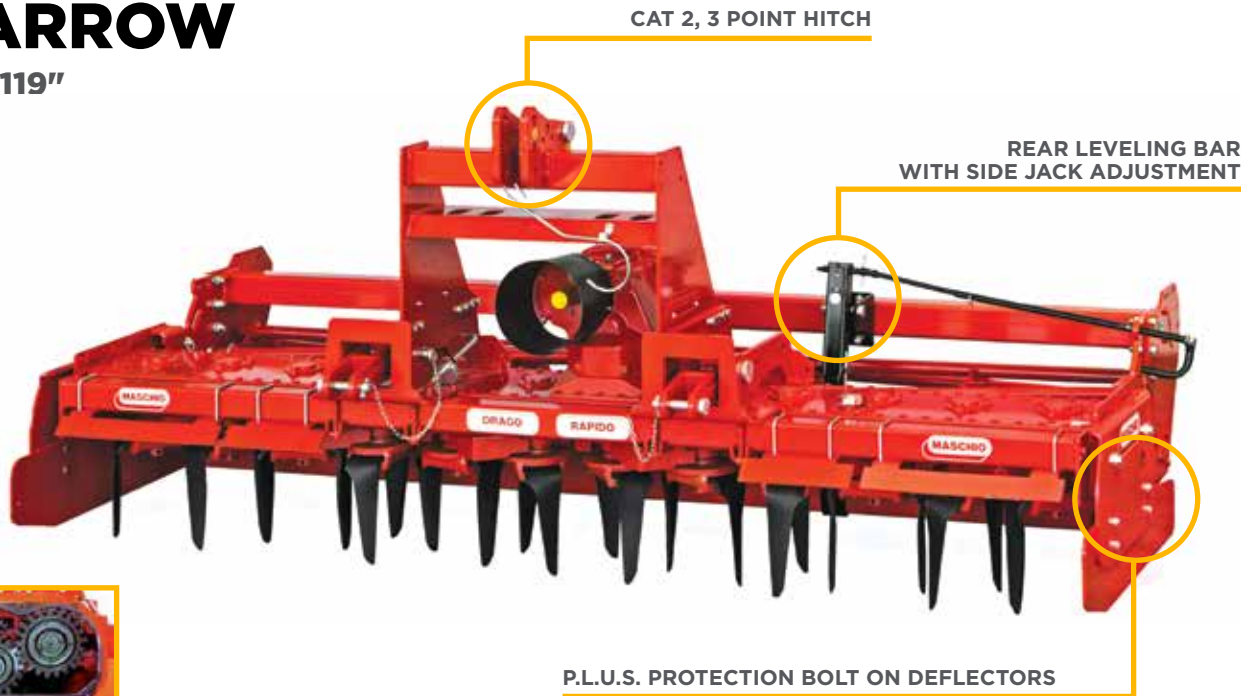

**MULTI SPEED GEARBOX**



\*CAGE ROLLER WITH MECHANICAL ADJUSTERS (WR MODELS)  
\*HYDRAULIC ADJUSTERS OPTIONAL

\*\*PACKER ROLLER WITH MECHANICAL ADJUSTERS (PR MODELS)

**DC SERIES 99"-119" 80-150 HP**

**DC SERIES POWER HARROW**

PART #	MAS-DC2500WR*	MAS-DC2500PR**	MAS-DC3000WR*	MAS-DC3000PR**
WEIGHT	2527 LBS	2509 LBS	2838 LBS	2818 LBS
TILLING WIDTH	99"	99"	119"	119"
TOTAL WIDTH	100"	100"	121"	121"
HP RATING	80 - 150 HP	80 - 150 HP	90 - 150 HP	90 - 150 HP
KW RATING	59 - 111	59 - 111	66 - 111	66 - 111
WORKING DEPTH	11"	11"	11"	11"
BLADES	20	20	24	24
CENTER SPECS	50"	50"	60"	60"

**REPLACEMENT WEAR PARTS FOR ALL UNITS**

PART	CCW BLADE	CW BLADE	BOLT KIT
PART #	63.000.060	63.000.061	04.016.050



**ROTARY TILLERS**



**MADE IN ITALY**  
**POWER HARROW**  
138", 158"

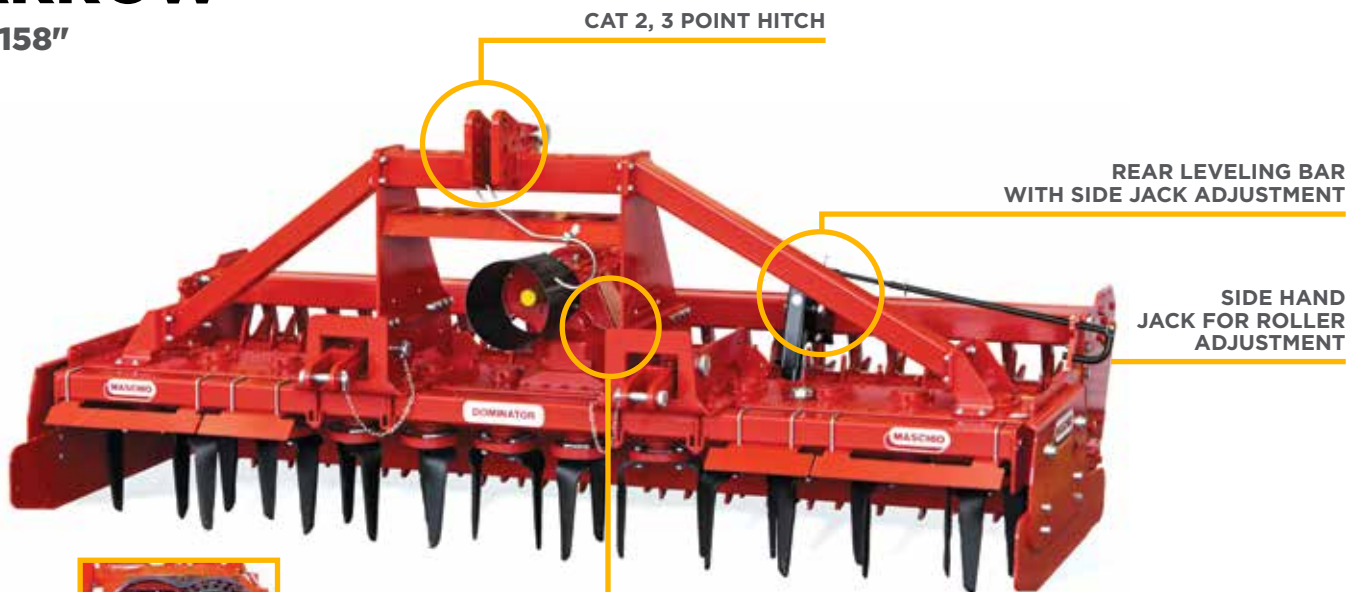

MULTI SPEED 540 & 1,000 RPM GEARBOX



\*CAGE ROLLER WITH MECHANICAL ADJUSTERS (WR MODELS)  
\*HYDRAULIC ADJUSTERS OPTIONAL

\*\*PACKER ROLLER WITH MECHANICAL ADJUSTERS (PR MODELS)  
\*HYDRAULIC ADJUSTERS OPTIONAL

**DM SERIES 138"-158" 120-180 HP**

**DM SERIES POWER HARROW**

PART #	MAS-DM3500WR*	MAS-DM3500PR**	MAS-DM4000WR*	MAS-DM4000SR***	MAS-DM4000PR**
WEIGHT	3044 LBS	3044 LBS	3331 LBS	3348 LBS	3331 LBS
TILLING WIDTH	138"	138"	158"	158"	158"
TOTAL WIDTH	140"	140"	160"	160"	160"
HP RATING	120 - 180 HP	120 - 180 HP	140 - 180 HP	140 - 180 HP	140 - 180 HP
KW RATING	95 - 132	95 - 132	105 - 132	105 - 132	105 - 132
WORKING DEPTH	12"	12"	12"	12"	12"
BLADES	28	28	32	32	32
CENTER SPECS	69"	69"	79"	79"	79"

**REPLACEMENT WEAR PARTS FOR ALL UNITS**

PART	CW ROTO SPIKE BLADE	CCW ROTO SPIKE BLADE	BOLT KIT
PART #	63.000.170	63.000.171	04.016.050

**MADE IN ITALY**  
**POWER HARROW**

**RAPIDO  
178"**

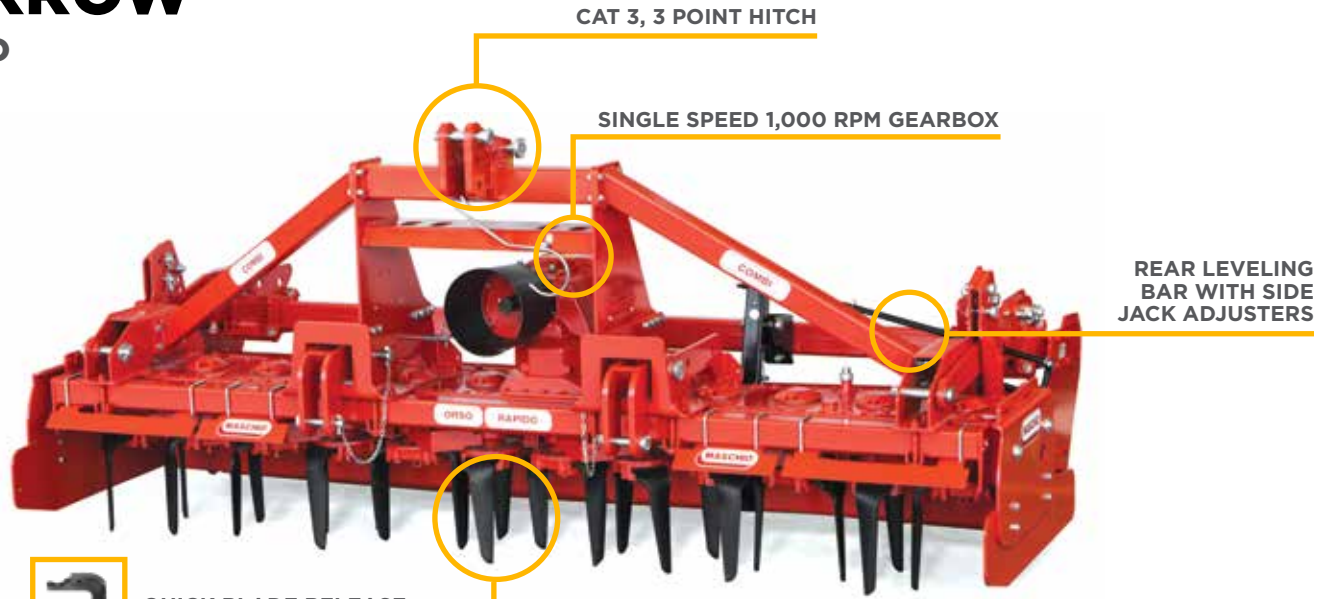

**QUICK BLADE RELEASE WITH SCREWED FLANGE**

**QUICK CHANGE BLADES**



**\*CAGE ROLLER WITH HYDRAULIC ADJUSTERS (WR MODELS)**

**\*\*PACKER ROLLER WITH HYDRAULIC ADJUSTERS (PR MODELS)**

**ORSO 178" 150-250 HP**

**ORSO POWER HARROW**

PART #	MAS-ORSO4500WR*	MAS-ORSO4500PR**
WEIGHT	4318 LBS	4907 LBS
TILLING WIDTH	178"	178"
TOTAL WIDTH	180"	180"
HP RATING	150 - 250 HP	150 - 250 HP
KW RATING	105 - 185	105 - 185
WORKING DEPTH	12"	12"
BLADES	36	36
CENTER SPECS	89"	89"

- Bolt-on steel deflectors (PLUS)
- Swinging front hitches
- Standard pair of gears: 19-26
- Round blade holders with 2 blades per rotor
- Heavy duty gear-tray with double reinforcement

**REPLACEMENT WEAR PARTS FOR ALL UNITS**

PART	CW BLADES	CCW BLADES
PART #	63.000.366	63.000.367

**ROTARY TILLERS**



**MADE IN ITALY**  
**POWER HARROW**

**RAPIDO PLUS 237"**

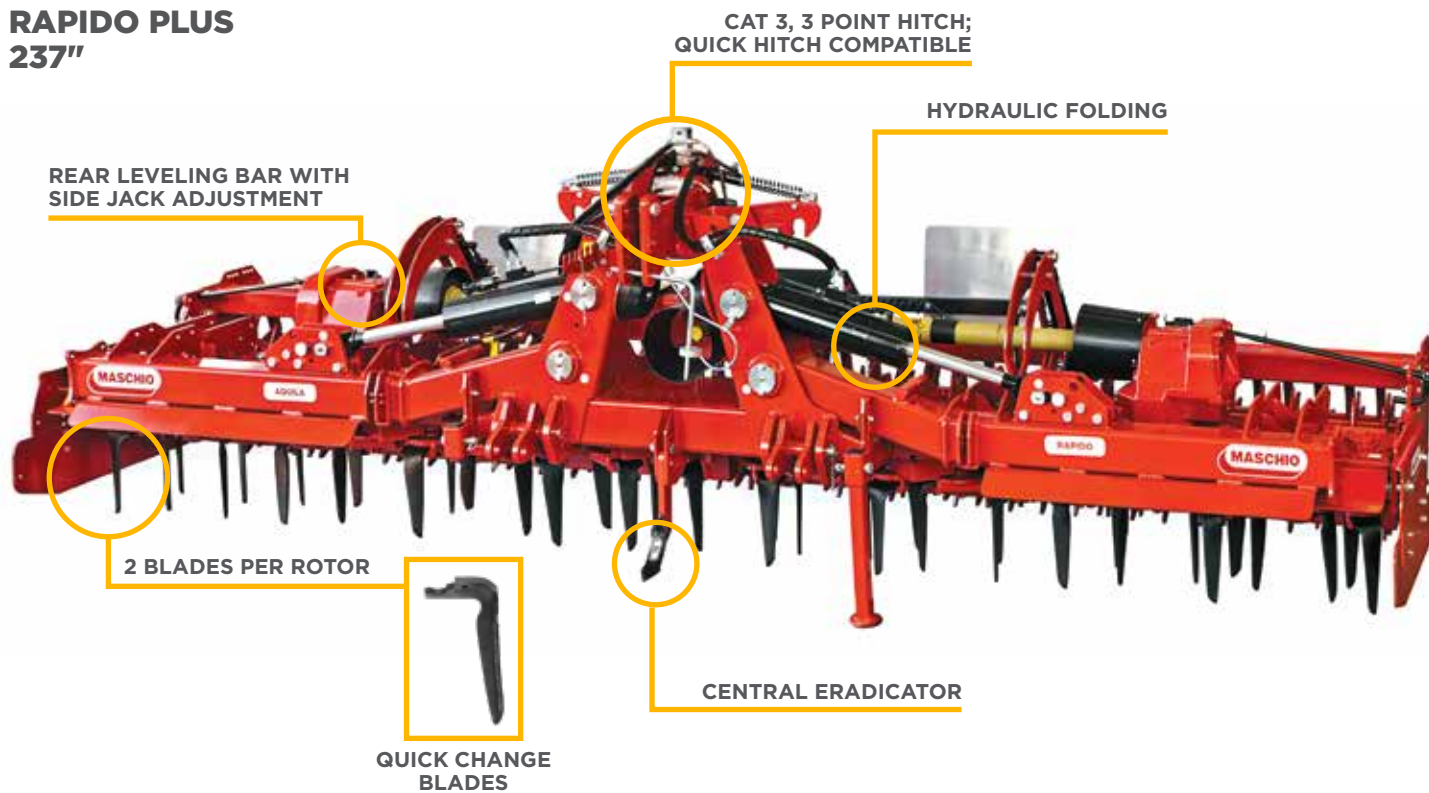

**AQUILA 237" 180-380 HP**

**AQUILA POWER HARROW**

PART #	MAS-AQ6000PR**
WEIGHT	7995 LBS
TILLING WIDTH	237"
TOTAL WIDTH	241"
TRANS WIDTH	95"
HP RATING	180 - 380 HP
KW RATING	133 - 198
WORK DEPTH	11"
BLADES	48
CENTER SPECS	118"

- Auxiliary rear PTO
- Pair of standard gears: 17-23
- Central direct PTO shaft
- Cam side PTO shafts
- Heavy duty gear-tray with double reinforcement
- Bolt-on steel deflectors (PLUS)
- Rear lights for transport
- Safety hydraulic locks for transport
- Round blade holders

**REPLACEMENT WEAR PARTS**

CW BLADES	63.000.366
CCW BLADES	63.000.367



**MADE IN ITALY**  
**POWER HARROW**

**RAPIDO PLUS 277"**

REAR LEVELING BAR WITH SIDE JACK ADJUSTMENT

CAT 4, 3 POINT HITCH

QUICK BLADE RELEASE  
2 BLADES PER ROTOR

CENTRAL ERADICATOR



QUICK CHANGE BLADES



\*\*PACKER ROLLER WITH HYDRAULIC ADJUSTER (PR MODELS)

**TORO 277" 180-380 HP**

**TORO POWER HARROW**

PART #	MAS-TORO7000PR**
WEIGHT	8805 LBS
TILLING WIDTH	277"
TOTAL WIDTH	281"
TRANS WIDTH	95"
HP RATING	250 - 380 HP
KW RATING	184 - 280
WORK DEPTH	12"
BLADES	56
CENTER SPECS	138"

- Auxiliary rear PTO
- Multi speed side gearbox
- Rear roller with mechanical adjustment
- Central 1,000 RPM gearbox with 3 tapered gears and rear PTO
- Air-cooled central and side gearboxes
- Standard pair of gears: 19-26
- Central direct PTO shaft
- Heavy duty gear-tray with double reinforcement
- Cam side PTO shafts
- Round blade holders
- Bolt-on steel deflectors (PLUS)
- Rear lights for transport
- Safety hydraulic locks for transport

**REPLACEMENT WEAR PARTS**

CW BLADES	63.000.366
CCW BLADES	63.000.367



**ROTARY TILLERS**



 **MADE IN ROMANIA**

**SURFACE  
DISC  
CULTIVATOR**

**99"**

**NEW!**

CAT 2, 3 POINT HITCH

NO MAINTENANCE SILENT  
BLOCK UNEVEN GROUND SYSTEM

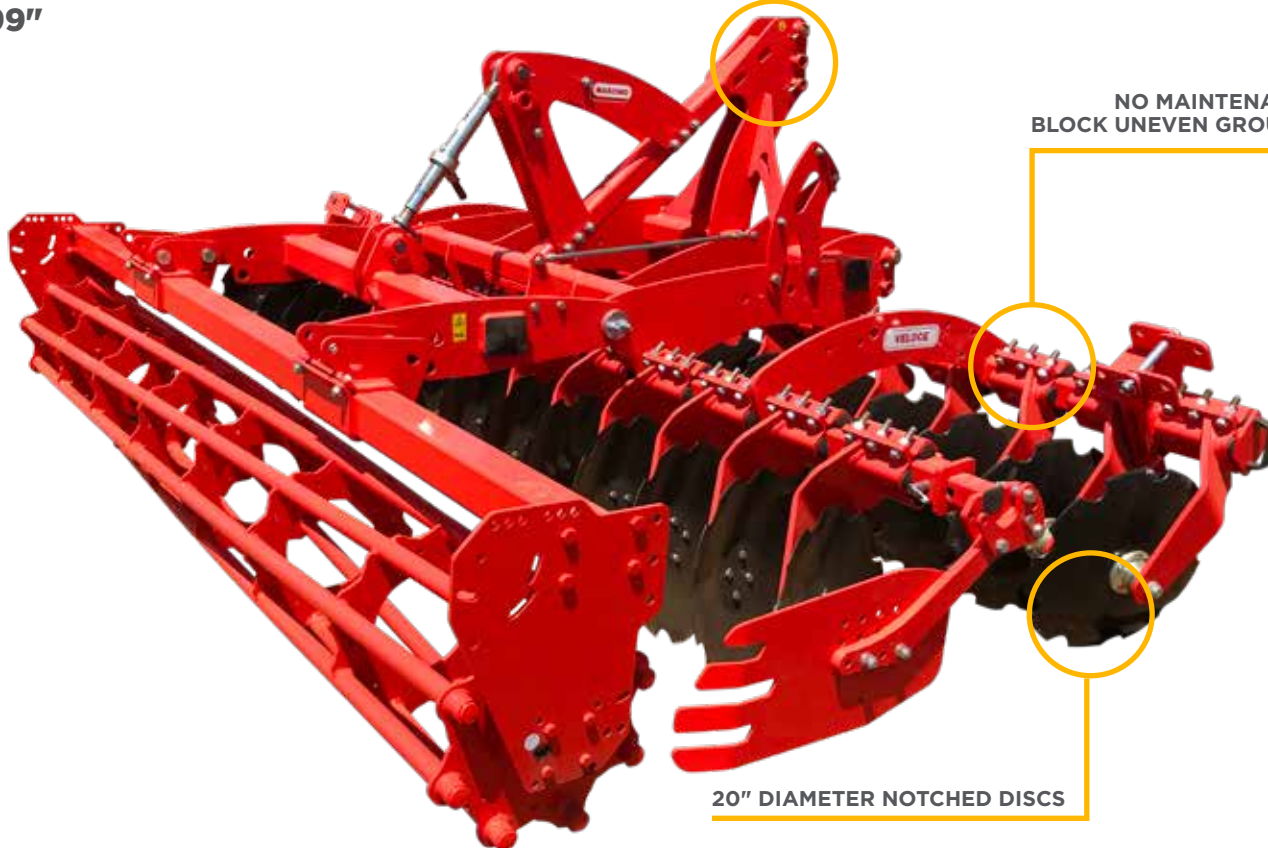

20" DIAMETER NOTCHED DISCS

**HIGH SPEED  
OPERATION  
UP TO  
9 MPH  
(15 KM/H)**

**IDEAL FOR MANAGING  
CROP RESIDUE, SEED BED  
PREPARATION, AND LIQUID  
FERTILIZER COVERING**



\*CAGE ROLLER  
WITH HYDRAULIC  
ADJUSTER  
(WR MODELS)

**VELOCE 99" 80-90 HP**

**SURFACE DISC CULTIVATOR**

PART #	MAS-VELOCE250WR*	MAS-VELOCE300WR*
WEIGHT	3265 LBS	3552 LBS
TILLING WIDTH	99"	118"
TOTAL WIDTH	101"	118"
HP RATING	80 - 90 HP	100 - 110 HP
WORK DEPTH	2" - 4"	2" - 4"
BLADES	20	24



20"  
DIAMETER



4" UNEVEN  
GROUND  
TRAVEL

\* UNIT PICTURED WITH SPIRAL ROLLER



**MADE IN ITALY**  
**SURFACE DISC CULTIVATOR**  
**236"**

**NEW!**



CAT 3 TRAILED WITH HYDRAULIC DRAWBAR

HYDRAULIC FOLDING FRAME

20" DIAMETER NOTCHED DISCS

NO MAINTENANCE SILENT BLOCK UNEVEN GROUND SYSTEM

HIGH SPEED OPERATION UP TO **9 MPH** (15 KM/H)

**IDEAL FOR MANAGING CROP RESIDUE, SEED BED PREPARATION, AND LIQUID FERTILIZER COVERING**

**4** TRACTOR HYDRAULIC PORTS REQUIRED



\*\*\*PACKER RING ROLLER WITH HYDRAULIC ADJUSTER (PRR MODELS)

**VELOCE 236" 200-260 HP**

**SURFACE DISC CULTIVATOR**

PART #	MAS-VELOCEP600PRR***
WEIGHT	11861 LBS
TILLING WIDTH	236"
TRANSPORT WIDTH	118"
HP RATING	200 - 260 HP
WORK DEPTH	4"
BLADES	40
BLADE DIAMETER	20"



20" DIAMETER



4" UNEVEN GROUND TRAVEL

\* UNIT PICTURED WITH SPIRAL ROLLER

**COMPACT  
3 POINT  
SNOW  
BLOWER**

54" UP TO 64"

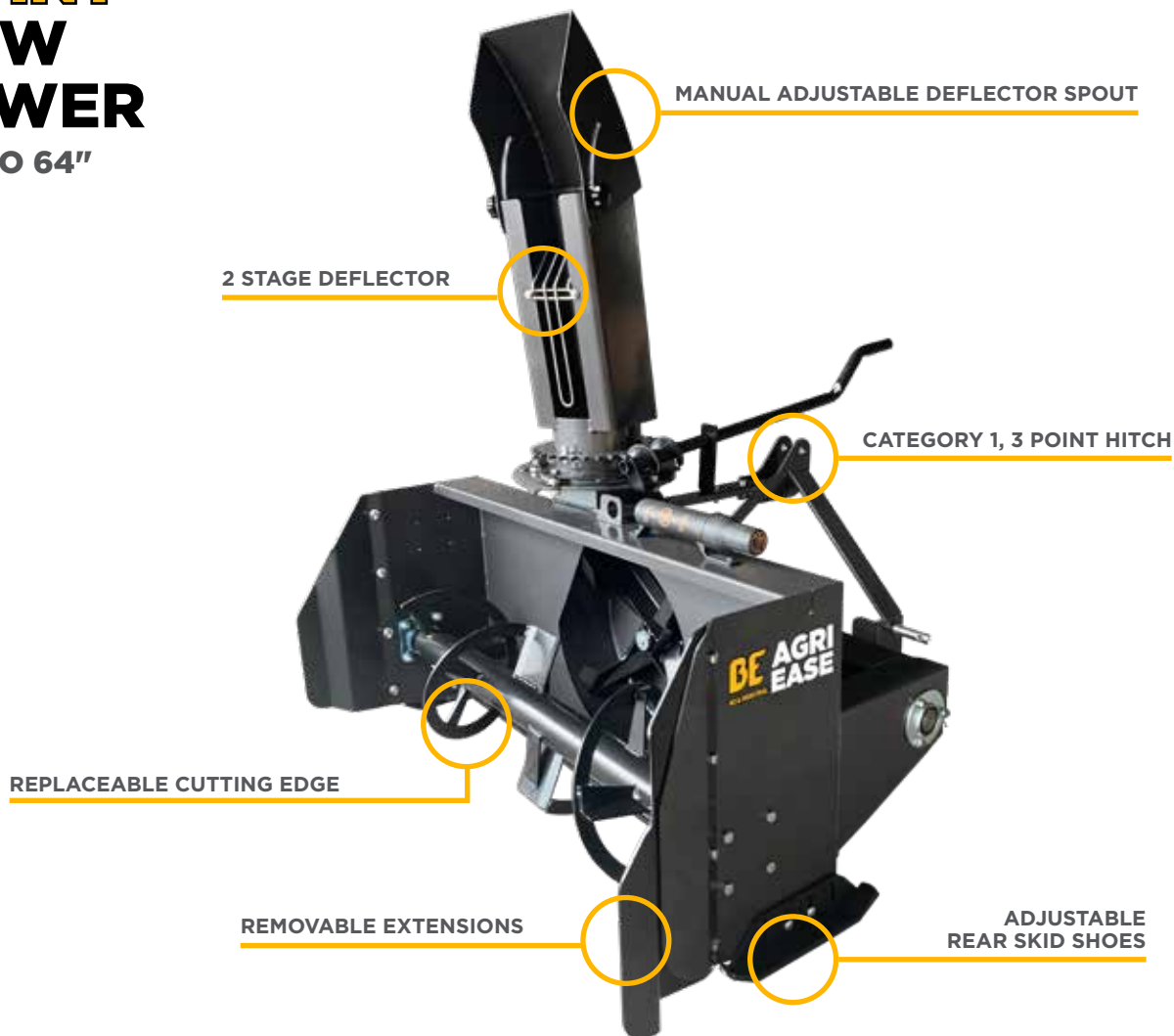

PART #	BE-SBS5054L	BE-SBS6064L
IMPELLER DIAMETER	20"	20"
CHUTE ROTATION	MANUAL	MANUAL
NUMBER OF STAGES	2	2
WEIGHT	440 LBS	595 LBS
HP RATING	UP TO 35 HP	UP TO 35 HP
WIDTH	50 / 54"	60 / 64"

**WIDTH EXTENSION**



SIDE VIEW



TOP VIEW

# 3 POINT SNOW BLOWER

54" UP TO 88"

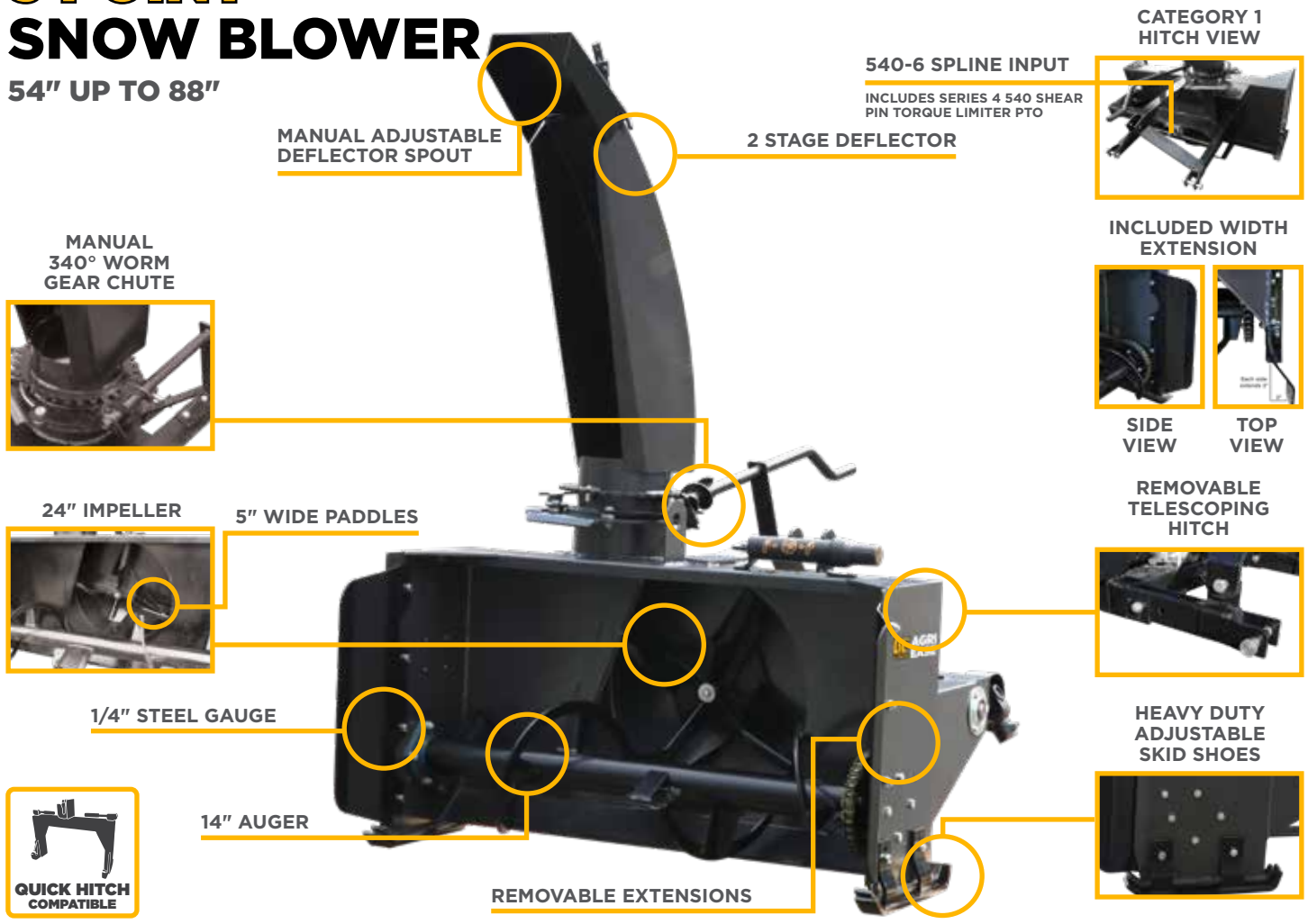

MANUAL ADJUSTABLE DEFLECTOR SPOUT

2 STAGE DEFLECTOR

540-6 SPLINE INPUT

INCLUDES SERIES 4 540 SHEAR PIN TORQUE LIMITER PTO

CATEGORY 1 HITCH VIEW



INCLUDED WIDTH EXTENSION



SIDE VIEW TOP VIEW

REMOVABLE TELESCOPING HITCH



HEAVY DUTY ADJUSTABLE SKID SHOES



MANUAL 340° WORM GEAR CHUTE



24" IMPELLER

5" WIDE PADDLES



1/4" STEEL GAUGE

14" AUGER

REMOVABLE EXTENSIONS



QUICK HITCH COMPATIBLE



540 RPM PTO



SHEAR PIN PTO YOKE

ALL MODELS INCLUDE 1 SET OF SBSEXTG WIDTH EXTENSIONS

OPTIONAL WIDTH EXTENSION SBSEXT6G



OPTIONAL HYDRAULIC CHUTE ROTATION KIT SBSNHYDKIT



PART #	BE-SBS5054G	BE-SBS6064G	BE-SBS6670G	BE-SBS7276G	BE-SBS7680G	BE-SBS8488G
WEIGHT	520 LBS	560 LBS	580 LBS	600 LBS	645 LBS	743 LBS
WIDTH	50 / 54"	60 / 64"	66 / 70"	72 / 76"	76 / 80"	84 / 88"
HP RATING	18 HP	22 HP	30 HP	40 HP	50 HP	55 HP
CHUTE ROTATION	MANUAL	MANUAL	MANUAL	MANUAL	MANUAL	MANUAL

## REPLACEMENT WEAR PARTS

PTO	69.888.400	69.888.400	69.888.400	69.888.400	69.888.400	69.888.400
SHEAR BOLT	01.008.050	01.008.050	01.008.050	01.008.050	01.008.050	01.008.050
GEAR BOX	SBSN57-2015G	SBSN57-2015G	SBSN57-2015G	SBSN57-2015G	SBSN57-2015G	SBSN57-2015G

## WIDTH EXTENSIONS (FOR MODELS SOLD BEFORE 2020)

PART #	SBSEXTG	SBSEXT6G
DESCRIPTION	2" WIDTH EXTENSIONS INCREASE WIDTH BY 4"	3" WIDTH EXTENSIONS INCREASE WIDTH BY 6"

## OPTIONS

PART #	SBSNHYDKIT
DESCRIPTION	HYDRAULIC CHUTE ROTATION KIT

# FRONT MOUNT BLADE

SKID STEER ATTACH  
60", 72", 84"

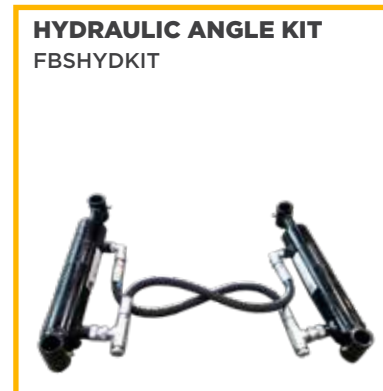
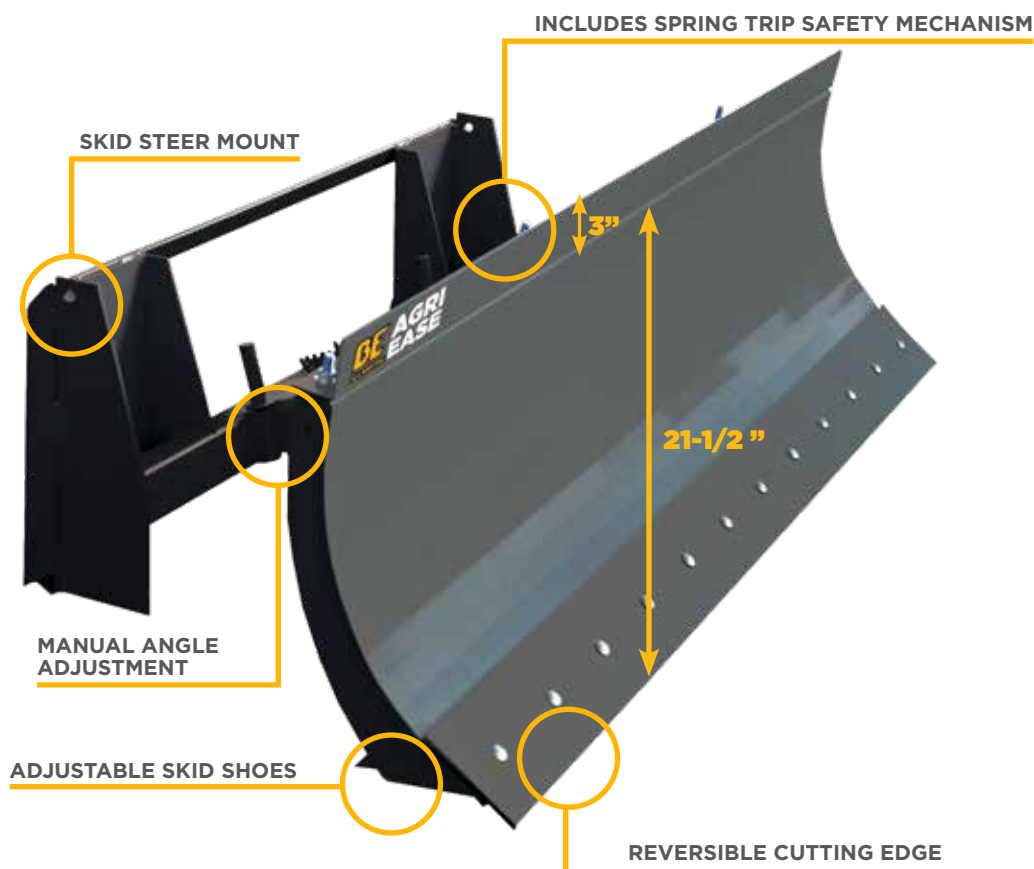

PART #	BE-FBS5BO500BK	BE-FBS6BO500BK	BE-FBS7BO500BK
WEIGHT	385 LBS	420 LBS	470 LBS
WIDTH	60"	72"	84"
HP RATING	UP TO 60 HP	UP TO 60 HP	UP TO 60 HP

## REPLACEMENT WEAR PARTS

CUTTING EDGE	350519	350619	350719
SPRING	350022	350022	350022
LEVELING SHOE	350006	350006	350006

**HEAVY DUTY SNOW PUSHER**

72", 84", 96"



SKID STEER MOUNT

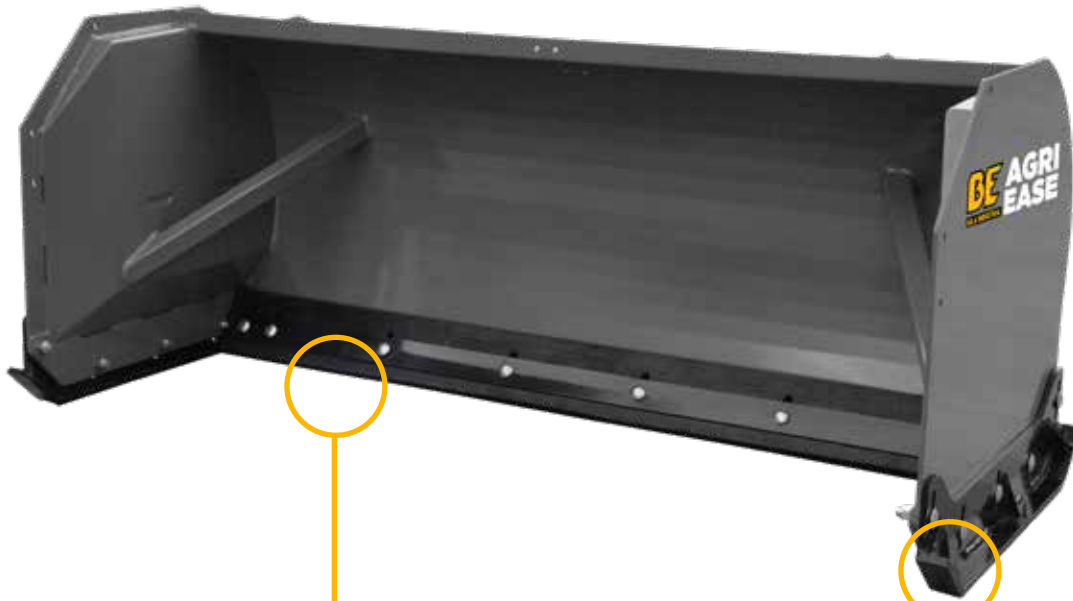

HEAVY DUTY REPLACEABLE RUBBER CUTTING EDGE

REVERSIBLE & FLIPPABLE. EQUALS 4 CUTTING EDGES

HEAVY DUTY SKID SHOES

PART #	BE-SPBBO6	BE-SPBBO7	BE-SPBBO8
DESCRIPTION	SNOW PUSHER 6' S/S	SNOW PUSHER 7' S/S	SNOW PUSHER 8' S/S
WIDTH	72"	84"	96"
WEIGHT	625 LBS	675 LBS	725 LBS

**REPLACEMENT WEAR PARTS**

RUBBER SCRAPER	690606G	690706G	690806G
SCRAPER HOLDER	690607G	690707G	690807G
SCRAPER BOLT	690605G	690705G	690605G
NYLOC NUT	09.000.016	09.000.016	09.000.016



# LIGHT DUTY/SUB COMPACT PALLET FORKS

<b>PART #</b>	<b>BE-PFLD36EBO</b>
CAPACITY	900 LBS
WEIGHT	170 LBS
FORK LENGTH	36"
CARRIAGE MOUNT	SKID STEER



**REPLACEMENT PARTS**

FORK	PFT36ELD
------	----------

# 2200-4400 LBS SKID STEER MOUNT PALLET FORKS



CLASS II LOCKING FORKS



REPLACEABLE STAINLESS LATCH

POWDER COAT FINISH

SKID STEER MOUNT

SLIDING ADJUSTABLE FORKS CAN BE LOCKED IN PLACE

EXTENSION AVAILABLE

PART# EXT3T2M  
PAGE 75



PART #	2200 LB PALLET FORKS			4400 LB PALLET FORKS	
	BE-PF30S36LBO	BE-PF30S42LBO	BE-PF50S42LBO	BE-PF50S42HBO	BE-PF50S48HBO
MOUNT	SKID STEER	SKID STEER	SKID STEER	SKID STEER	SKID STEER
FORKS	36"	42"	42"	42"	48"
WEIGHT	284 LBS	310 LBS	349 LBS	387 LBS	440 LBS
CAPACITY	2200 LBS	2200 LBS	2200 LBS	4400 LBS	4400 LBS
CARRIAGE	47" LOCKING	47" LOCKING	47" LOCKING	47" LOCKING	47" LOCKING

**REPLACEMENT PARTS**

FORK	PFT36LDJ	PFT42LDJ	PFT42LDJ	PFT42HDJ	PFT48HDJ
------	----------	----------	----------	----------	----------

**2200 LBS  
SKID STEER  
MOUNT  
PALLET  
FORKS**

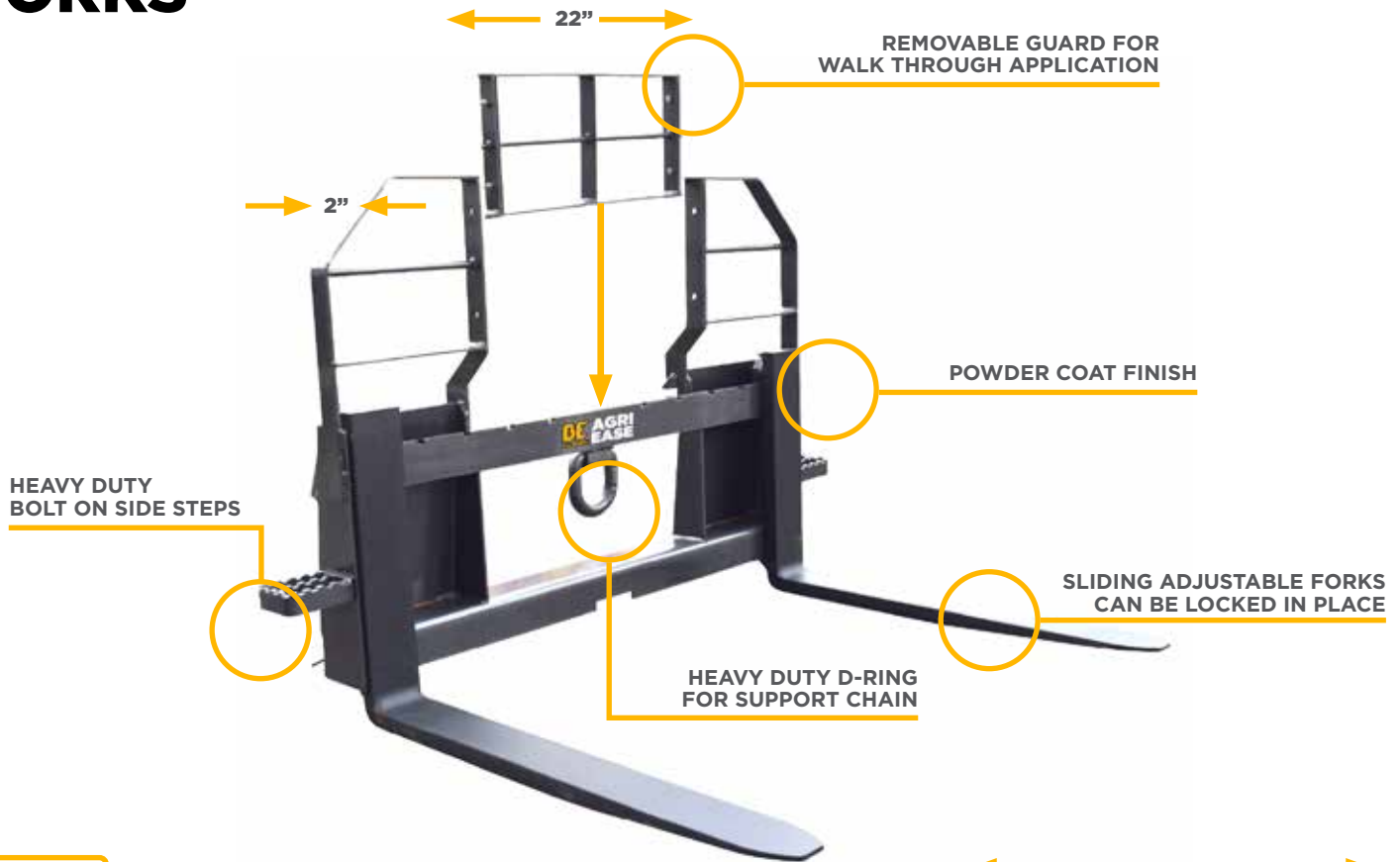

PART #	BE-PF3036LBO500J	BE-PF3042LBO500J
MOUNT	SKID STEER	SKID STEER
FORKS	36"	42"
WEIGHT	284 LBS	310 LBS
CAPACITY	2200 LBS	2200 LBS
CARRIAGE	47" LOCKING	47" LOCKING

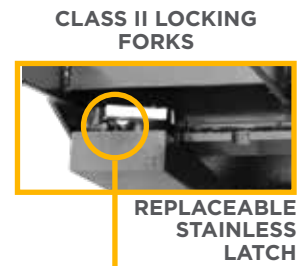

**REPLACEMENT PARTS**

FORK	PFT36LDJ	PFT42LDJ
------	----------	----------



**PALLET FORKS**

**4400 LBS  
SKID STEER  
AND EURO  
MOUNT  
PALLET  
FORKS**

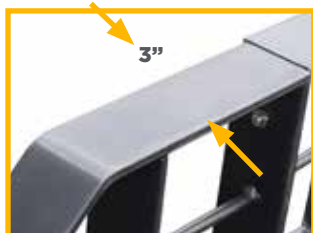
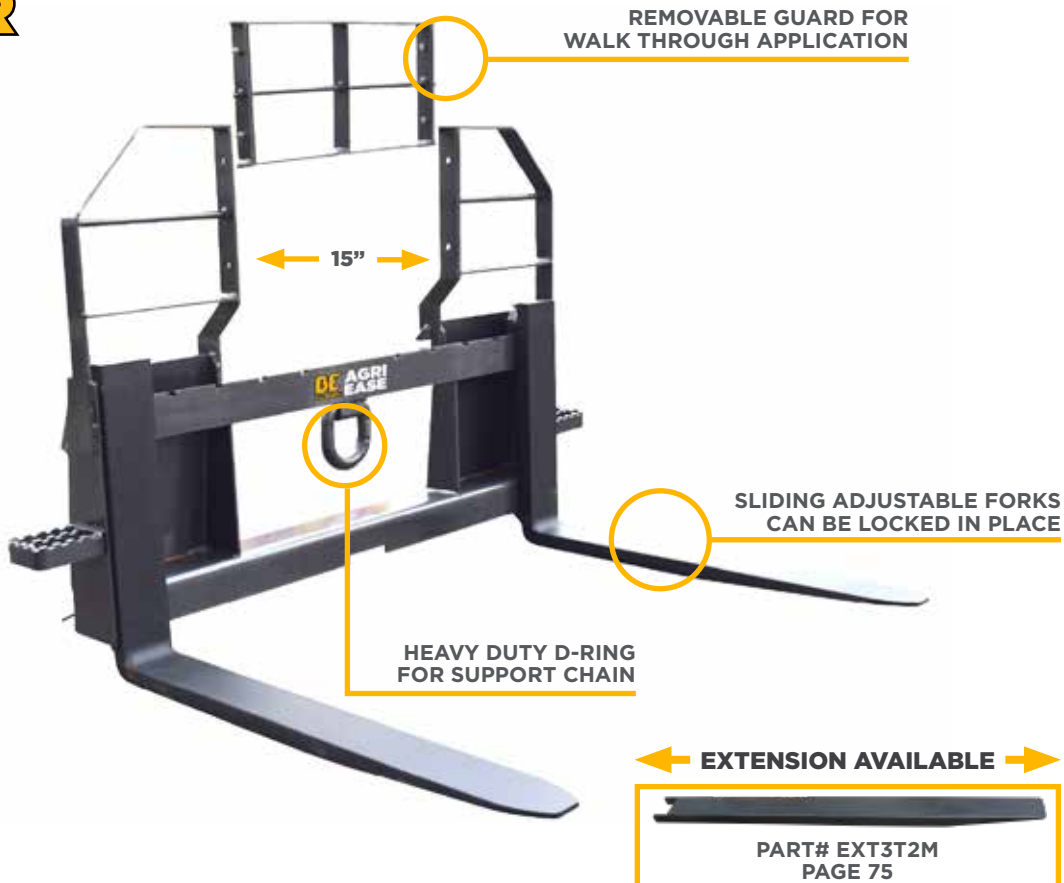

**SKID STEER & EURO MOUNT VERSIONS AVAILABLE**



**4400 LBS SKID STEER VERSIONS**

PART #	BE-PF5042LBO500J	BE-PF5042HBO500J	BE-PF5048HBO500J
MOUNT	SKID STEER	SKID STEER	SKID STEER
FORKS	42"	42"	48"
WEIGHT	387 LBS	414 LBS	440 LBS
CAPACITY	2200 LBS	4400 LBS	4400 LBS
CARRIAGE	47" LOCKING	47" LOCKING	47" LOCKING

**REPLACEMENT PARTS**

FORK	PFT42LDJ	PFT42HDJ	PFT48HDJ
------	----------	----------	----------

**EURO MOUNT VERSIONS**

PART #	BE-HD4442AO600	BE-HD4448AO600
MOUNT	EURO	EURO
FORKS	42"	48"
WEIGHT	430 LBS	466 LBS
CAPACITY	4400 LBS	4400 LBS
CARRIAGE	50" LOCKING	50"



**REPLACEMENT PARTS**

FORK	PFT42HDJ	PFT48HDJ
------	----------	----------

**HEAVY DUTY  
5500 LBS  
SKID STEER  
& EURO MOUNT  
PALLET  
FORKS**

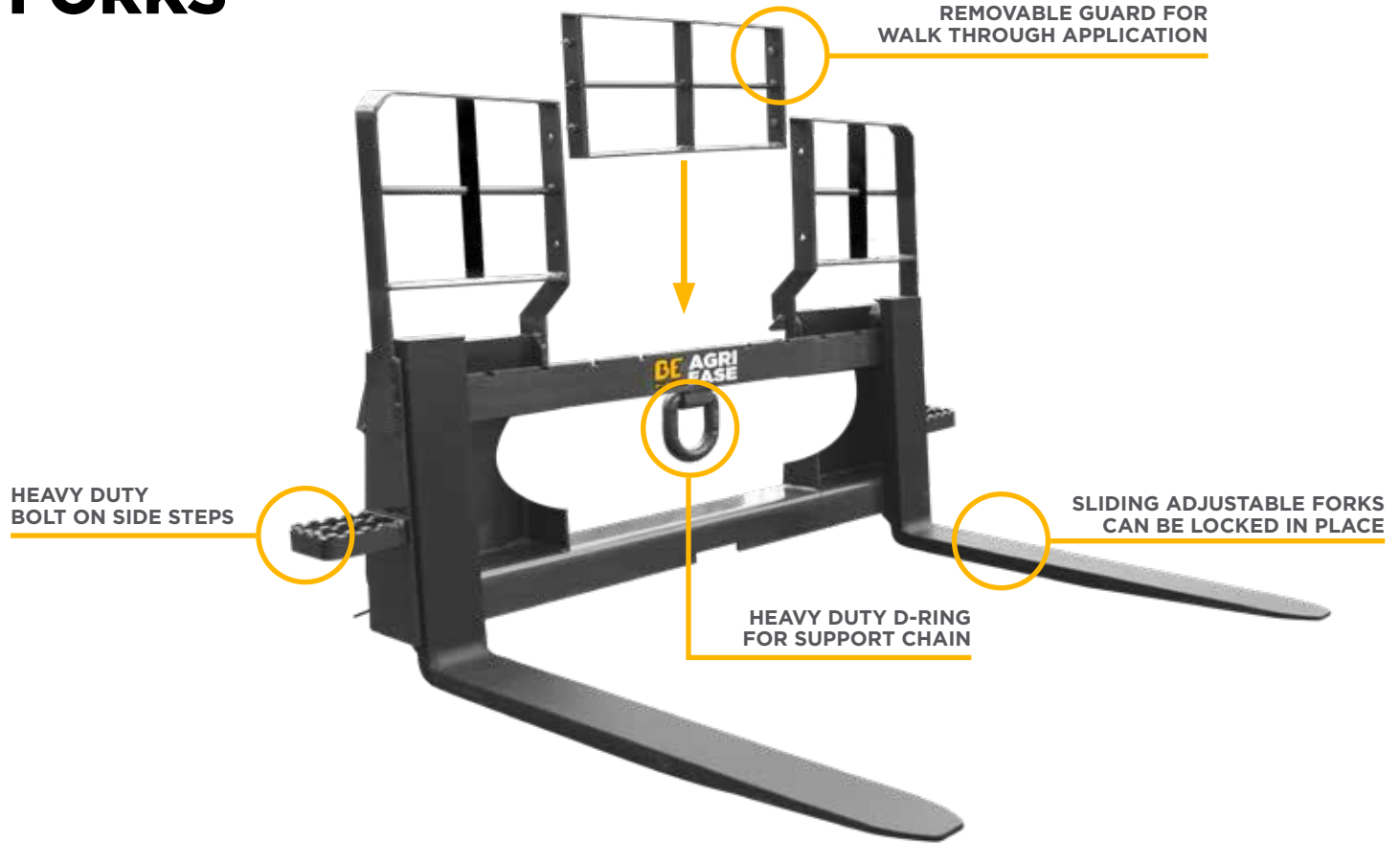

**SKID STEER & EURO MOUNT VERSIONS AVAILABLE**



← EXTENSION AVAILABLE →

PART# EXT3T2M  
PAGE 75

PART #	BE-HD5548BO500	BE-HD5548AO600
MOUNT	SKID STEER	EURO
FORKS	48"	48"
WEIGHT	587 LBS	556 LBS
CAPACITY	5500 LBS	5500 LBS
CARRIAGE	50" LOCKING	50" LOCKING

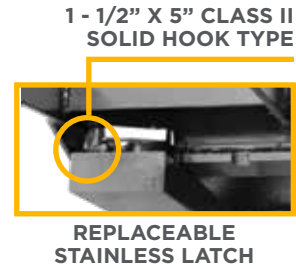

**REPLACEMENT PARTS**

FORK	PFT48HDJ5500	PFT48HDJ5500
------	--------------	--------------

**PALLET FORKS**

**LOADER  
PALLET  
FORKS**

FITS JOHN DEERE MOUNT  
COMPLETE WITH FORKS



REAR VIEW

**FITS  
SERIES  
100, 200,  
300, 400  
& 500  
LOADERS!**

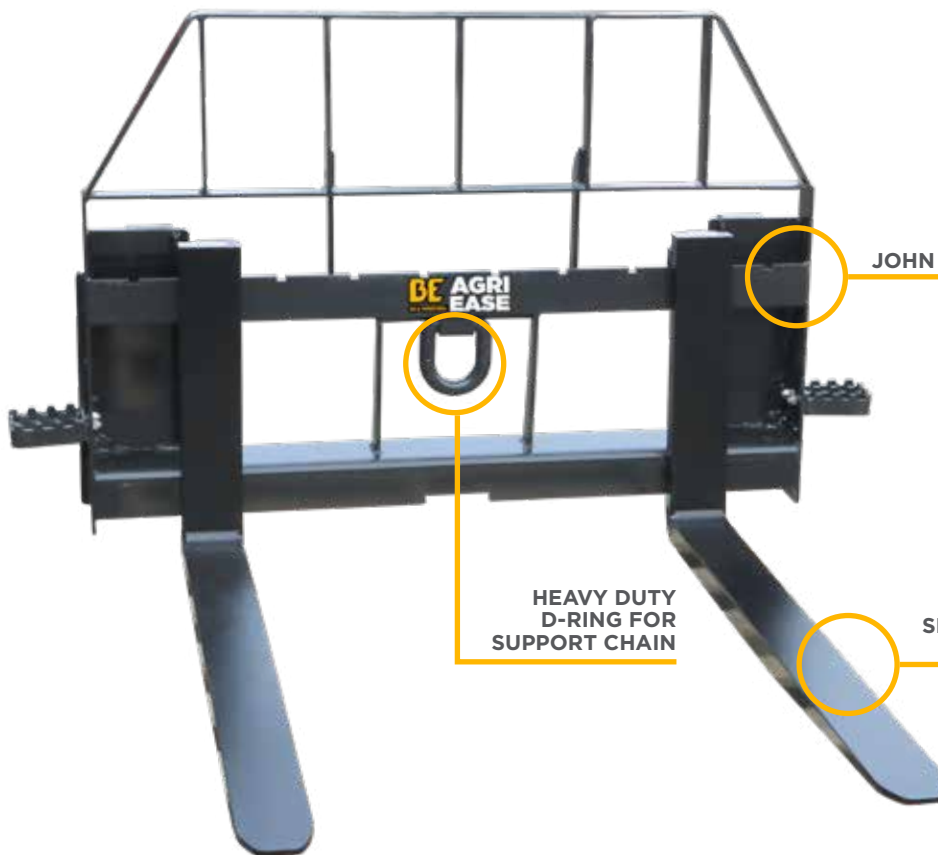

JOHN DEERE MOUNT

HEAVY DUTY  
D-RING FOR  
SUPPORT CHAIN

SLIDING ADJUSTABLE FORKS  
CAN BE LOCKED IN PLACE



← EXTENSION AVAILABLE →



PART# EXT3T2M  
PAGE 75

PART #	BE-JD3742LAP12F	BE-JD3748HAP12F
MOUNT	FITS JOHN DEERE	FITS JOHN DEERE
WEIGHT	340 LBS	404 LBS
FORKS	42"	48"
CAPACITY	2200 LBS	4400 LBS
CARRIAGE	48" LOCKING	49" LOCKING

FITS SERIES 100, 200, 300,  
400 & 500 LOADERS

**REPLACEMENT PARTS**

FORK	PFT42LDJ	PFT48HDJ
------	----------	----------



**HEAVY DUTY  
7500 LBS  
SKID STEER  
PALLET  
FORKS**



**48" CARRIAGE WIDTH**

PART #	BE-HD7548BO48	BE-HD7554BO48	BE-HD7560BO48	BE-HD7572BO48
MOUNT	SKID STEER	SKID STEER	SKID STEER	SKID STEER
FORKS	48"	54"	60"	72"
WEIGHT	705 LBS	733 LBS	761 LBS	821 LBS
CAPACITY	7500 LBS	7500 LBS	7500 LBS	7500 LBS
CARRIAGE	48"	48"	48"	48"

**60" CARRIAGE WIDTH**

PART #	BE-HD7548BO60	BE-HD7554BO60	BE-HD7560BO60	BE-HD7572BO60
MOUNT	SKID STEER	SKID STEER	SKID STEER	SKID STEER
FORKS	48"	54"	60"	72"
WEIGHT	765 LBS	793 LBS	821 LBS	881 LBS
CAPACITY	7500 LBS	7500 LBS	7500 LBS	7500 LBS
CARRIAGE	60"	60"	60"	60"

**REPLACEMENT  
PALLET  
FORK TINES**

PART #	PFT48C3	PFT54C3	PFT60C3	PFT72C3
MOUNT	CLASS III	CLASS III	CLASS III	CLASS III
WEIGHT	160 LBS	174 LBS	188 LBS	218 LBS
CAPACITY (PER PAIR)	7500 LBS	7500 LBS	7500 LBS	7500 LBS
LENGTH	48"	54"	60"	72"



# HEAVY DUTY 10,000 LBS SKID STEER PALLET FORKS



## 48" CARRIAGE WIDTH

PART #	BE-HD10048BO48	BE-HD10054BO48	BE-HD10060BO48	BE-HD10072BO48
MOUNT	SKID STEER	SKID STEER	SKID STEER	SKID STEER
FORKS	48"	54"	60"	72"
WEIGHT	817 LBS	855 LBS	895 LBS	975 LBS
CAPACITY	10000 LBS	10000 LBS	10000 LBS	10000 LBS
CARRIAGE	48"	48"	48"	48"

## 60" CARRIAGE WIDTH

PART #	BE-HD10048BO60	BE-HD10054BO60	BE-HD10060BO60	BE-HD10072BO60
MOUNT	SKID STEER	SKID STEER	SKID STEER	SKID STEER
FORKS	48"	54"	60"	72"
WEIGHT	877 LBS	915 LBS	955 LBS	1035 LBS
CAPACITY	10000 LBS	10000 LBS	10000 LBS	10000 LBS
CARRIAGE	60"	60"	60"	60"

# REPLACEMENT HEAVY DUTY PALLET FORK TINES

PART #	PFT48C3HD	PFT54C3HD	PFT60C3HD	PFT72C3HD
MOUNT	CLASS III	CLASS III	CLASS III	CLASS III
WEIGHT	216 LBS	235 LBS	255 LBS	295 LBS
CAPACITY (PER PAIR)	10000 LBS	10000 LBS	10000 LBS	10000 LBS
LENGTH	48"	54"	60"	72"



# REPLACEMENT PALLET FORK TINES

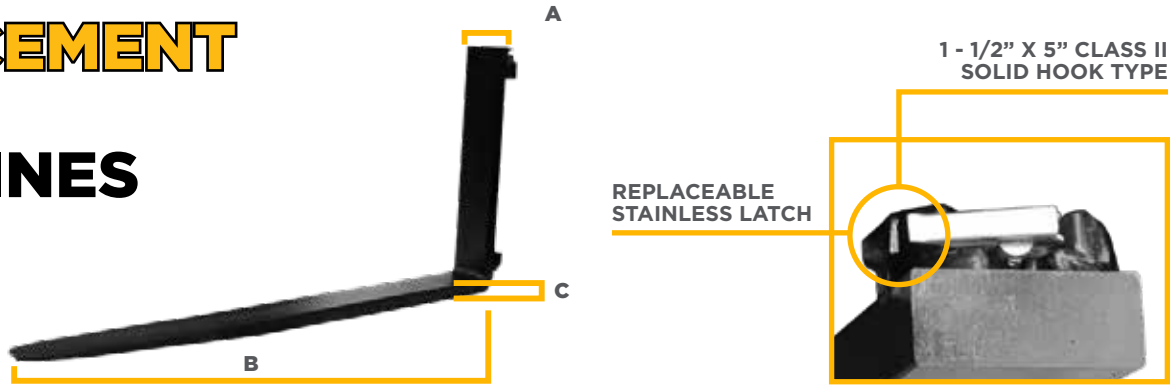

PART #	PFT36ELD	PFT36LDJ	PFT42LDJ	PFT42HDJ	PFT48HDJ	PFT48HDJ5500
MOUNT	CLASS II A	CLASS II A	CLASS II A	CLASS II A	CLASS II A	CLASS II A
WEIGHT	45 LBS	75 LBS	85 LBS	101 LBS	112 LBS	130 LBS
CAPACITY (PER PAIR)	1100 LBS	2200 LBS	2200 LBS	4400 LBS	4400 LBS	5500 LBS
A	3"	4"	4"	4"	4"	4-3/4"
B	36"	36"	42"	42"	48"	48"
C	1"	1.25"	1.25"	1.5625"	1.5625"	1.5625"

# FORK EXTENSION

**2 METERS, 6.6', 110 LB**  
EXT3T2M



**OSHA REQUIRES FORK EXTENSION LENGTH TO BE NO LONGER THAN 150% OF THE LENGTH OF THE SUPPORT FORKS**

# 3 POINT BIN & PALLET FORK



PART #	ABFG	ABFHDN
CAPACITY	1200 LBS	2000 LBS
HITCH	CAT 1, 3 POINT	CAT 1, 3 POINT
SIZE	L41" X 25" CENTER	L41" X 25" CENTER
FORK SIZE	2" X 4" TUBE	1-1/4" X 4" SOLID
WEIGHT	90 LBS	174 LBS

# 3 POINT CARRY-ALLS

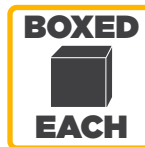

PART #	CAFAGHDN
WEIGHT	92 LBS
PINS	CAT 1
LENGTH	32-1/2"
WIDTH	33"
CAPACITY	1000 LBS

**PALLET FORKS & DEBRIS FORKS**

**CLAMP-ON  
PALLET FORK KIT**

WITH STABILIZER BAR



COMPATIBLE WITH BUCKETS!

**BOXED  
& SOLD**  
  
**AS PAIRS!**

PART #	CAPACITY	WEIGHT	TOTAL LENGTH	FORK LENGTH	FORK WIDTH	FORK THICKNESS
BFT1002N	1000 LBS	115 LBS	45-3/4"	32"	3-1/4"	2"
BFT2002N	2000 LBS	183 LBS	64"	44"	4"	2"

**REPLACEMENT  
CLAMP-ON PALLET  
FORK**

**MIX &  
MATCH  
& SAVE!**

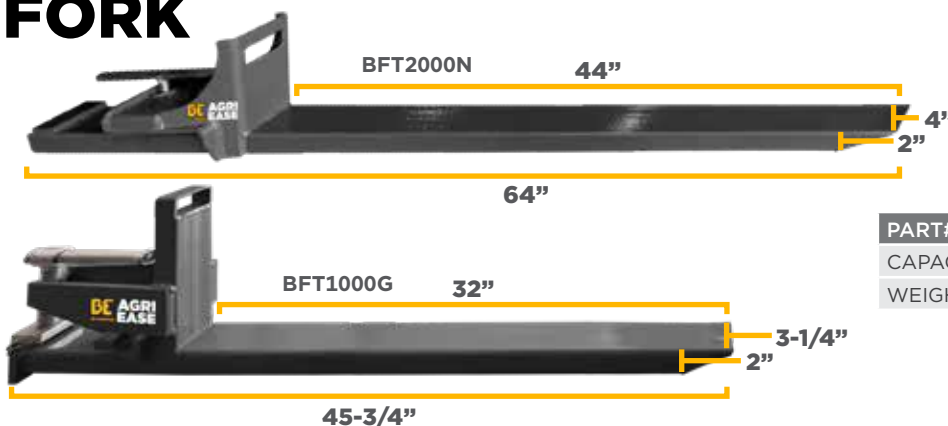

**STABILIZER  
BAR**



PART#	BFT10GSTAB	BFT20GSTAB
MIN LENGTH		20-3/4"
MAX LENGTH		38-1/4"
# OF ADJ. POSITIONS		9

PART#	BFT1000G	BFT2000N
CAPACITY	1000 LBS	2000 LBS
WEIGHT	51 LBS	85 LBS

**CLAMP-ON DEBRIS FORKS**

**MIX &  
MATCH  
& SAVE!**

PART #	BE-DF48N	BE-DF54N	BE-DF60N	BE-DF72N
WEIGHT	150 LBS	160 LBS	170 LBS	200 LBS
WIDTH	48"	54"	60"	72"
MOUNT	TO BUCKET	TO BUCKET	TO BUCKET	TO BUCKET
FRAME WIDTH	46"	53-3/4"	58"	70"
FORK WIDTH	42-1/2"	50"	54"	67"
FITS BUCK SIZE	48"+	54"+	60"+	72"+
WORKING LENGTH	18"	18"	18"	18"
FORKS	5	5	6	7
FORK SPACING	10"	12"	10-1/2"	11"



## CLASS IIA MOUNT BALE SPEAR



PART #	BE-PFBS39	BE-PFBS49
TINE LENGTH	39"	49"
USABLE LENGTH	34"	44"
CAPACITY	2000 LBS	2000 LBS

## SINGLE BALE SPEAR WITH CHAIN

PART #	BE-BSBM1N	BE-BSBM2G
WEIGHT	105 LBS	135 LBS
MOUNT	TO BUCKET	TO BUCKET
TINE	SINGLE	DOUBLE
TINE LENGTH	40"	40"
USABLE LENGTH	34"	34"
CHAINS	YES	YES



### REPLACEMENT WEAR PARTS

BALE SPEAR	60.000.004	60.000.004
CONUS	60.000.002	60.000.002
LOAD BINDER	64.100.002	64.100.002

\*MAY SHIP DISASSEMBLED

## 3 POINT HITCH BALE SPEAR

PART #	BE-BS3PTN
WEIGHT	95 LBS
CAPACITY	2500 LBS
HITCH	CAT 1 & 2

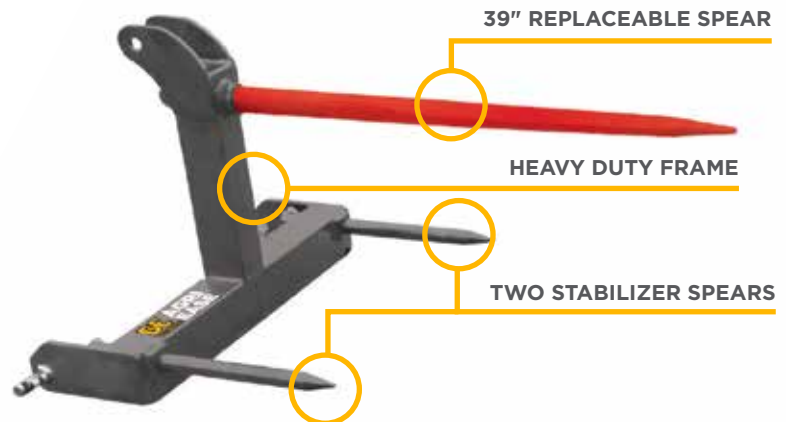

### REPLACEMENT WEAR PARTS

BALE SPEAR	60.000.004
STABILIZER	BS3PTSTAB

\*MAY SHIP DISASSEMBLED



**BALE SPEARS**

**SKID STEER  
MOUNT  
SINGLE PRONG  
BALE SPEAR**

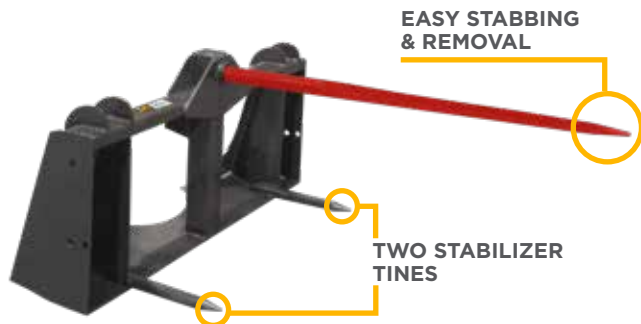

PART #	BE-BSS39BO500G	BE-BSS49BO500G
WEIGHT	148 LBS	150 LBS
MOUNT	SKID STEER	SKID STEER
TINE LENGTH	39"	49"
USE LENGTH	34"	44"
CAPACITY	2000 LBS	2000 LBS

**REPLACEMENT WEAR PARTS**

BALE SPEAR	60.000.004	60.000.005
CONUS	60.000.002	60.000.002

PART	DESCRIPTION
BE-BSGUARD	BALE GUARD

\*MAY SHIP DISASSEMBLED

**SKID STEER  
MOUNT  
DOUBLE PRONG  
BALE SPEAR**



PART #	BE-BSD39BO500G	BE-BSD49BO500G
WEIGHT	176 LBS	180 LBS
MOUNT	SKID STEER	SKID STEER
TINE LENGTH	39"	49"
USE LENGTH	34"	44"
CAPACITY	2000 LBS	2000 LBS

**REPLACEMENT WEAR PARTS**

BALE SPEAR	60.000.004	60.000.005
CONUS	60.000.002	60.000.002

PART	DESCRIPTION
BE-BSGUARD	BALE GUARD

\*MAY SHIP DISASSEMBLED

**SKID STEER  
MOUNT  
TRIPLE PRONG  
BALE SPEAR**

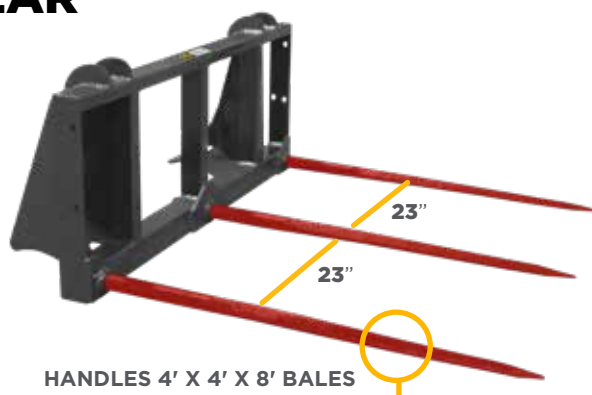

PART #	BE-BST39BO500G	BE-BST49BO500G
WEIGHT	150 LBS	154 LBS
MOUNT	SKID STEER	SKID STEER
TINE LENGTH	39"	49"
USE LENGTH	34"	44"
CAPACITY	2000 LBS	2000 LBS

**REPLACEMENT WEAR PARTS**

BALE SPEAR	60.000.004	60.000.005
CONUS	60.000.002	60.000.002

PART	DESCRIPTION
BE-BSGUARD	BALE GUARD

\*MAY SHIP DISASSEMBLED

**ALO/EURO  
MOUNT  
SINGLE PRONG  
BALE SPEAR**

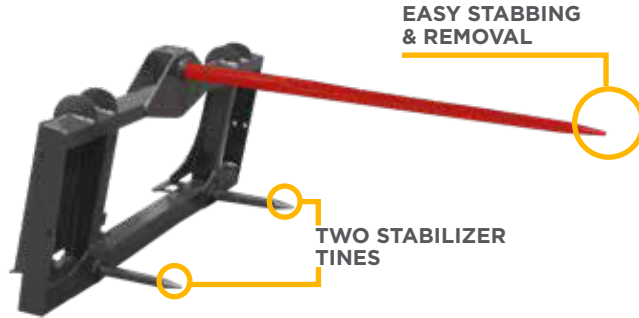

PART #	BE-BSS39EUROG	BE-BSS49EUROG
WEIGHT	148 LBS	150 LBS
MOUNT	ALO/EURO	ALO/EURO
TINE LENGTH	39"	49"
USE LENGTH	34"	44"
CAPACITY	2000 LBS	2000 LBS

**REPLACEMENT WEAR PARTS**

BALE SPEAR	60.000.004	60.000.005
CONUS	60.000.002	60.000.002



PART	DESCRIPTION
BE-BSGUARD	BALE GUARD

\*MAY SHIP DISASSEMBLED

**ALO/EURO  
MOUNT  
DOUBLE PRONG  
BALE SPEAR**



PART #	BE-BSD39EUROG	BE-BSD49EUROG
WEIGHT	176 LBS	180 LBS
MOUNT	ALO/EURO	ALO/EURO
TINE LENGTH	39"	49"
USE LENGTH	34"	44"
CAPACITY	2000 LBS	2000 LBS

**REPLACEMENT WEAR PARTS**

BALE SPEAR	60.000.004	60.000.005
CONUS	60.000.002	60.000.002



PART	DESCRIPTION
BE-BSGUARD	BALE GUARD

\*MAY SHIP DISASSEMBLED

**ALO/EURO  
MOUNT  
TRIPLE PRONG  
BALE SPEAR**

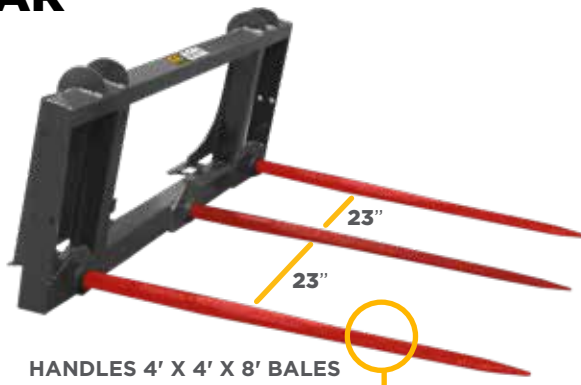

PART #	BE-BST39EUROG	BE-BST49EUROG
WEIGHT	150 LBS	154 LBS
MOUNT	ALO/EURO	ALO/EURO
TINE LENGTH	39"	49"
USE LENGTH	34"	44"
CAPACITY	2000 LBS	2000 LBS

**REPLACEMENT WEAR PARTS**

BALE SPEAR	60.000.004	60.000.005
CONUS	60.000.002	60.000.002



PART	DESCRIPTION
BE-BSGUARD	BALE GUARD

\*MAY SHIP DISASSEMBLED

# SKID STEER GRAPPLE BUCKET

36"

THE GRAPPLE BUCKET IS IDEAL FOR PICKING UP AND MOVING ROCKS, LOGS, BRUSH, DEBRIS, AND OTHER ODDLY SHAPED OR HARD-TO-LIFT MATERIAL. THE INDEPENDENT GRAPPLE MAKES IT EASY TO MOVE DIFFICULT AND UNEVEN LOADS.

PART #	BE-SSGB3236
WEIGHT	336 LBS
WIDTH	36"
OPENING HEIGHT	32"
HYDRAULIC PORTS	2

- Universal Skid Steer style hookup
- Greasable pins and bushings
- One cylinder
- Hoses and Pioneer Type couplers are included



SKID STEER MOUNT



# SKID STEER GRAPPLE BUCKET

42"

THE GRAPPLE BUCKET IS IDEAL FOR PICKING UP AND MOVING ROCKS, LOGS, BRUSH, DEBRIS, AND OTHER ODDLY SHAPED OR HARD-TO-LIFT MATERIAL. THE INDEPENDENT GRAPPLE MAKES IT EASY TO MOVE DIFFICULT AND UNEVEN LOADS.

PART #	BE-SSGB2242
WEIGHT	253 LBS
WIDTH	42"
OPENING HEIGHT	22"
HYDRAULIC PORTS	2

- Universal Skid Steer style hookup
- Greasable pins & bushings
- One cylinder
- Hoses and Pioneer Type couplers are included

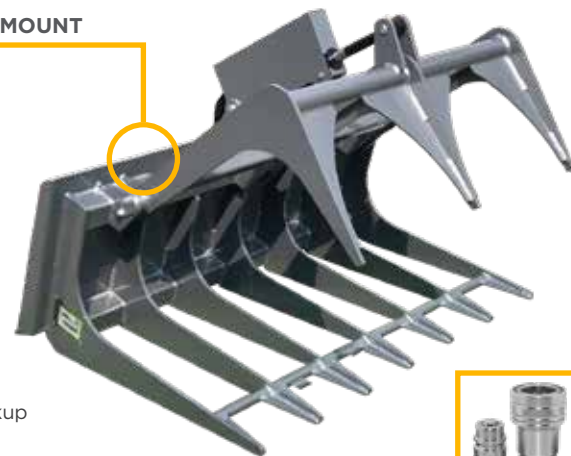

SKID STEER MOUNT



# SKID STEER GRAPPLE BUCKET

54"

THE GRAPPLE BUCKET IS IDEAL FOR PICKING UP AND MOVING ROCKS, LOGS, BRUSH, DEBRIS, AND OTHER ODDLY SHAPED OR HARD-TO-LIFT MATERIAL. THE INDEPENDENT GRAPPLE MAKES IT EASY TO MOVE DIFFICULT AND UNEVEN LOADS.

PART #	BE-SSGB2254
WEIGHT	310 LBS
WIDTH	54"
OPENING HEIGHT	22"
HYDRAULIC PORTS	2

- Universal Skid Steer style hookup
- Greasable pins & bushings
- One cylinder
- Hoses and Pioneer Type couplers are included



SKID STEER MOUNT



# SKID STEER GRAPPLE BUCKET

60"

PART #	BE-SSGB60
WEIGHT	650 LBS
WIDTH	60"
OPENING HEIGHT	34"
TEETH LENGTH	24"
HYDRAULIC PORTS	2

- Universal Skid Steer style hookup
- Greasable pins and bushings
- Twin 3,000 PSI cylinders
- Hoses and Pioneer Type couplers are included
- Cylinder back stoppers prevent the upper clamps from getting stuck in the upright position or hyper extended.



SKID STEER MOUNT



# SKID STEER GRAPPLE BUCKET

72"

PART #	BE-SSGB72
WEIGHT	700 LBS
WIDTH	72"
OPENING HEIGHT	34"
TEETH LENGTH	24"
HYDRAULIC PORTS	2

- Universal Skid Steer style hookup
- Greasable pins and bushings
- Twin 3,000 PSI cylinders
- Hoses and Pioneer Type couplers are included
- Cylinder back stoppers prevent the upper clamps from getting stuck in the upright position or hyper extended.

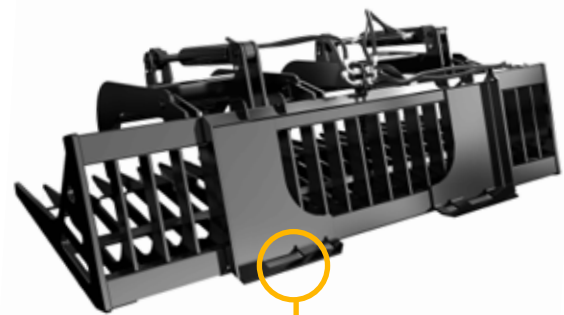

SKID STEER MOUNT



# SKID STEER GRAPPLE BUCKET

84"

PART #	BE-SSGB84
WEIGHT	800 LBS
WIDTH	84"
OPENING HEIGHT	34"
TEETH LENGTH	24"
HYDRAULIC PORTS	2

- Universal Skid Steer style hookup
- Greasable pins and bushings
- Twin 3,000 PSI cylinders
- Hoses and Pioneer Type couplers are included
- Cylinder back stoppers prevent the upper clamps from getting stuck in the upright position or hyper extended.

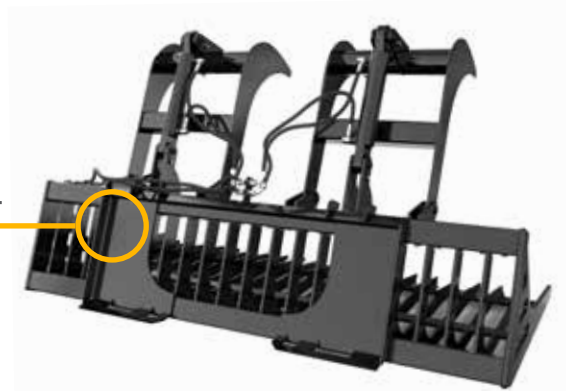

SKID STEER MOUNT



**SKID STEER ATTACHMENTS**

**HEAVY  
DUTY  
ROOT  
GRAPPLE  
BUCKET**

62", 77"

**THIS HEAVY DUTY ROOT GRAPPLE BUCKET RAKES, DIGS, AND MOVES ROCKS, TREES, BRUSH, AND CONSTRUCTION DEBRIS FROM THE GROUND WITHOUT PICKING UP DIRT.**



PART #	BE-SSGBC60	BE-SSGBC75
WEIGHT	395 LBS	491 LBS
WIDTH	62"	77"
OPENING HEIGHT	39-1/2"	39-1/2"
HYDRAULIC PORTS	2	2

- Universal Skid Steer style hookup
- Dual hydraulic cylinders
- High volume cage design
- Hoses & dripless type couplers Included
- Rear facing lower teeth
- Large diameter pins



**HEAVY  
DUTY  
ROOT  
GRAPPLE  
BUCKET**

66", 79"

**THIS HEAVY DUTY ROOT GRAPPLE BUCKET RAKES, DIGS, AND MOVES ROCKS, TREES, BRUSH, AND CONSTRUCTION DEBRIS FROM THE GROUND WITHOUT PICKING UP DIRT.**



PART #	BE-SSGBS67	BE-SSGBS80
WEIGHT	614 LBS	740 LBS
WIDTH	66"	79"
OPENING HEIGHT	34-3/4"	34-3/4"
HYDRAULIC PORTS	2	2

- Universal Skid Steer style hookup
- Two cylinder independent grapples secure uneven loads
- Open bottom and back allows dirt to fall through
- Hoses & dripless type couplers Included
- Large diameter pins





# SKID STEER TREE SPADE



SKID STEER MOUNT

PART #	BE-SSTS36
WEIGHT	278 LBS
OVERALL WIDTH	45.4"
SPADE LENGTH	36.1"
SPADE WIDTH	36.8"
SPADE TIP	5.9"
OVERALL HEIGHT	22.7"
OVERALL LENGTH	38.35"

- 36" wide spade for digging, carrying and planting large saplings, trees and shrubs.
- Allows you to transplant and save trees and shrubs.
- Universal skid steer quick attach style backplate.
- Gusset and reinforced spade and backplate mean this attachment is built to last for years.

# SKID STEER & JOHN DEERE TREE STUMP UPROOTER



JOHN DEERE MOUNT VERSION

PART #	BE-SSTS37	BE-JDTS37
MOUNT TYPE	SKID STEER	JOHN DEERE
TOTAL HEIGHT	17.85"	17.85"
TOTAL WIDTH	45.47"	45.47"
TOTAL LENGTH	39.5"	39.5"
WORKING LENGTH	37"	37"
WORKING WIDTH	36.5"	36.5"
WEIGHT	164 LBS	164 LBS

**THE STUMP BUCKET FOR SKID STEER IS PERFECT FOR UPROOTING TREE STUMPS, LIFTING CONCRETE SLABS AND FOR DIGGING FOOTING AROUND A HOUSE.**

**THE LEADING EDGE OF THE BUCKET IS DESIGNED TO SHRED ROOTS AND OTHER DEBRIS WITHOUT HAVING TO USE A SAW OR SHEARS. THE RELIABLE STEEL CONSTRUCTION ENSURES THAT THIS BUCKET CAN HANDLE MOST RECREATIONAL & PROFESSIONAL JOBS.**

**USED IN CONSTRUCTION, LANDSCAPING, FARMING & FORESTRY.**

- Skid steer mount
- Heavy duty steel body
- Serrated leading edge

# BUCKET MOUNT QUICK SPADE

PART #	BE-SSQS28
WEIGHT	98 LBS
TOTAL LENGTH	45"
TOTAL WIDTH	17"
TOTAL HEIGHT	5.2"
SPADE WORKING SURFACE (L X W)	27-1/2" X 17-3/4"



## SKID STEER ATTACHMENTS

### SKID STEER GRADER

PART #	BE-SSGS6
MOUNT TYPE	SKID STEER
WEIGHT	710 LBS
GRADING WIDTH	72"
OVERALL WIDTH	76.38"
OVERALL LENGTH	63.15"
CUTTING EDGE SPREAD FROM FRONT	15" - 35" - 45.8"



**THE PERFECT ATTACHMENT FOR GRADING, SPREADING, LEVELING, ROAD & PARKING LOT MAINTENANCE & MORE!**

- Triple cutting edge design is the best in the industry.
- Two forward facing edges and one rear facing edge.
- Compacts and allows you to move material in forward position. Skim and cover skid steer tracks in reverse.
- Fixed pitch design allows you to cut through tough material.
- Bucket stops allow you to transport the bucket on top of the grader.

### SKID STEER BALE GRABBER

PART #	BE-SSB76
MOUNT TYPE	SKID STEER
WORKING WIDTH CAPACITY	40" - 76"
MAX LOAD	1760 LBS
WEIGHT	600 LBS
HYDRAULIC PORTS	2



### SKID STEER CONCRETE CLAW

PART #	BE-SSCC52
MOUNT TYPE	SKID STEER
REAR OPENING HEIGHT	9"
WORKING DEPTH	44"
WORKING WIDTH	24"
OVERALL HEIGHT	22"
OVERALL DEPTH	52"
OVERALL WIDTH	47"
WEIGHT	726 LBS



## SMALL QUICK ATTACH LOADER BUCKET

54"

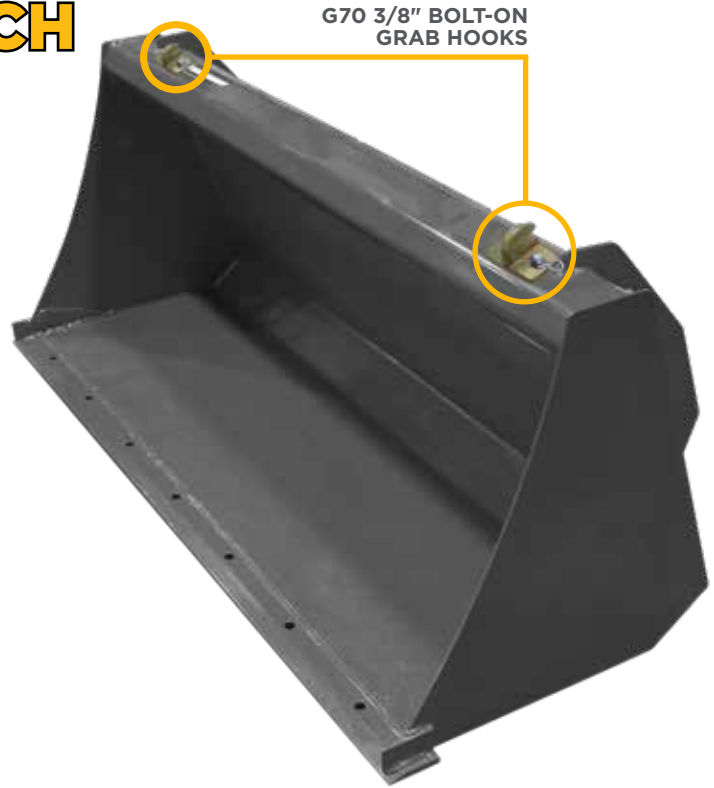

G70 3/8" BOLT-ON  
GRAB HOOKS

PART #	BE-LBS54
MOUNT TYPE	SKID STEER
WEIGHT	195 LBS
WORKING WIDTH	54"
HEIGHT	22.5"
DEPTH	21"

## MEDIUM QUICK ATTACH LOADER BUCKET

66"

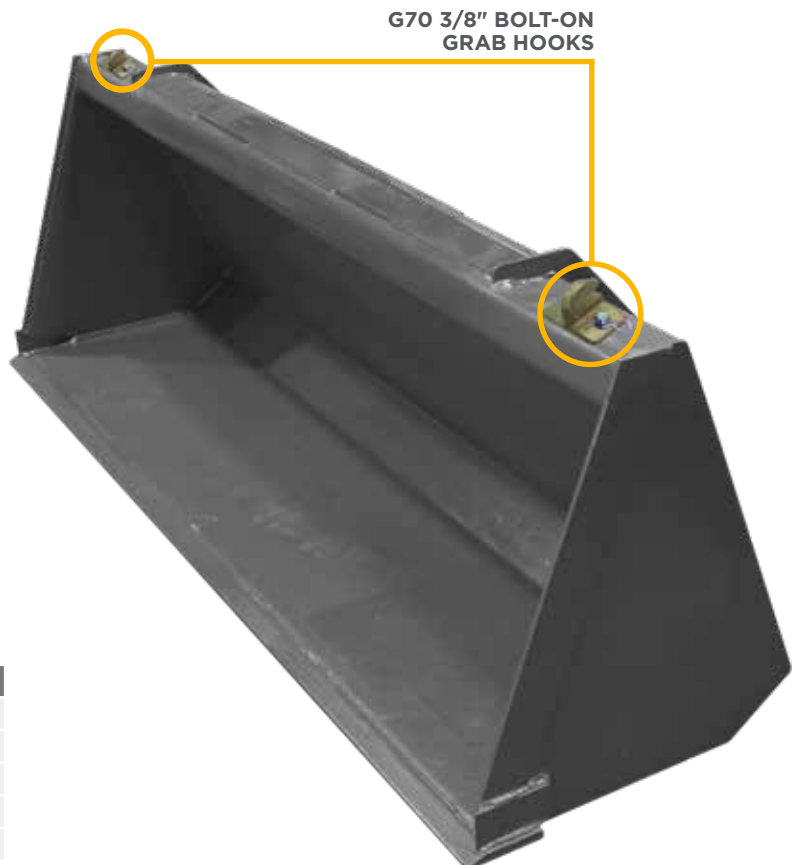

G70 3/8" BOLT-ON  
GRAB HOOKS

PART#	BE-LBM66
MOUNT TYPE	SKID STEER
WEIGHT	284 LBS
WORKING WIDTH	66"
HEIGHT	22.5"
DEPTH	19"

**SKID STEER ATTACHMENTS**

**STANDARD  
BUCKET**

54", 60", 66", 72"



SKID STEER MOUNT

REAR VIEW



PART #	BE-FB054GS	BE-FB060GS	BE-FB066GS	BE-FB072GS
MOUNT TYPE	SKID STEER	SKID STEER	SKID STEER	SKID STEER
WEIGHT	137 LBS	150 LBS	161 LBS	172 LBS
WORKING WIDTH	54"	60"	66"	72"
LOAD CAPACITY LEVEL LOAD	0.19 YD <sup>3</sup>	0.22 YD <sup>3</sup>	0.24 YD <sup>3</sup>	0.26 YD <sup>3</sup>
LOAD CAPACITY RATED LOAD	0.27 YD <sup>3</sup>	0.30 YD <sup>3</sup>	0.33 YD <sup>3</sup>	0.36 YD <sup>3</sup>

**HEAVY DUTY  
BUCKET**

54", 60", 66", 72"



SKID STEER MOUNT

REAR VIEW

BOLT-ON REPLACEABLE  
CUTTING EDGE



PART#	BE-FBH054GS	BE-FBH060GS	BE-FBH066GS	BE-FBH072GS
MOUNT TYPE	SKID STEER	SKID STEER	SKID STEER	SKID STEER
WEIGHT	260 LBS	282 LBS	302 LBS	324 LBS
WORKING WIDTH	54"	60"	66"	72"
DEPTH	20"	20"	20"	20"
HEIGHT	20.6"	20.6"	20.6"	20.6"
CUTTING EDGE PART#	715010014	715010027	715010040	715010053
CUTTING EDGE MATERIAL	65MN	65MN	65MN	65MN
CUTTING EDGE WEIGHT	26.5 LBS	29.3 LBS	32.4 LBS	35.3 LBS
BOLTS PART #	505011737	505011737	505011737	505011737
BOLTS SIZE	M10X35	M10X35	M10X35	M10X35
LOAD CAPACITY FT <sup>3</sup> LEVEL LOAD	0.26	0.29	0.31	0.34
LOAD CAPACITY FT <sup>3</sup> RATED LOAD	0.38	0.42	0.46	0.51

**4-IN-1  
CLAMSHELL  
TRACTOR  
LOADER  
BUCKET**

60", 66", 72"



SKID STEER MOUNT

**2**  
TRACTOR  
HYDRAULIC  
PORTS  
REQUIRED

• Pioneer Type couplers are included



PART #	BE-CFB060	BE-CFB066	BE-CFB072
MOUNT TYPE	SKID STEER	SKID STEER	SKID STEER
WEIGHT	452 LBS	476 LBS	498 LBS
WORKING WIDTH	60"	66"	72"
BUCKET CAPACITY	0.29 M <sup>3</sup> / 10.24 FT <sup>3</sup>	0.32 M <sup>3</sup> / 11.3 FT <sup>3</sup>	0.35 M <sup>3</sup> / 12.36 FT <sup>3</sup>
HYDRAULIC PORTS	2	2	2



**SKID STEER ATTACHMENTS**

**HEAVY DUTY  
ROCK BUCKET**

WITH TEETH  
60", 72"

**NEW!**

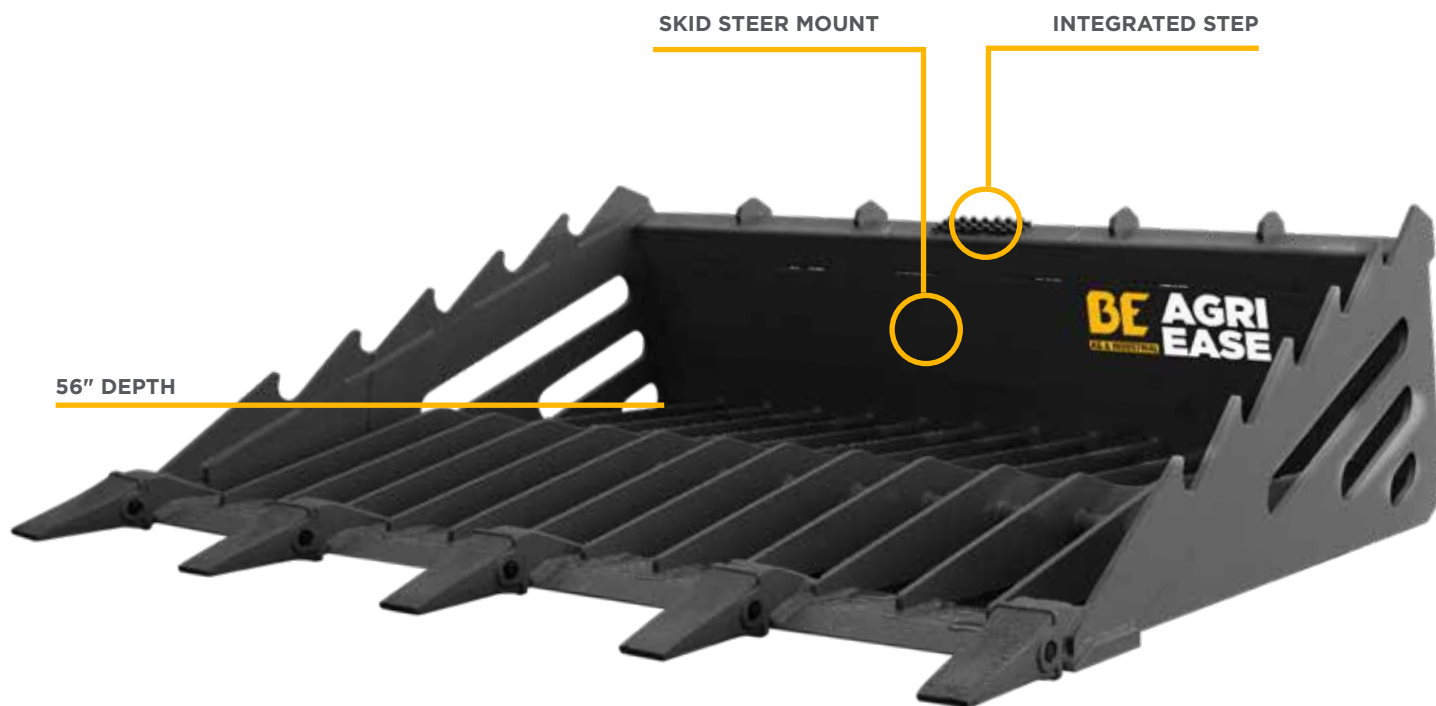

PART #	BE-DB060TA	BE-DB072TA
MOUNT TYPE	SKID STEER	SKID STEER
WEIGHT	604 LBS	706 LBS
WORKING WIDTH	60"	72"
DEPTH	56"	56"
HEIGHT	13-1/2"	13-1/2"
TEETH	5	6

# SKID STEER WELD-ON ADAPTER PLATE

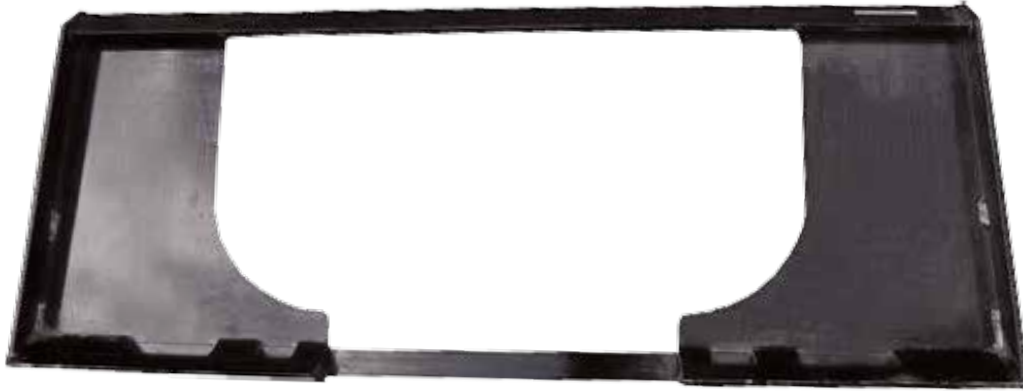

**BOXED**  
  
**EACH**

PART #	ABSS	ABSSTOR
HEIGHT	18-7/8"	10-1/4"
WIDTH	47-1/4"	24-1/4"
DEPTH	3-1/8"	3-1/8"

# WELD-ON MOUNT



**BOXED**  
  
**ONE PAIR  
PER BOX**

**WELD-ON EURO  
MOUNT SET**

**WELD-ON JOHN  
DEERE MOUNT SET**

PART #	WOKAO600 (PAIR)	JDBFSET (PAIR)
DESCRIPTION	ALO & EURO MOUNT	JD MOUNT
WEIGHT	36 LBS	33 LBS

# SKID STEER ATTACHMENTS

## COMPLETE SKID STEER POST HOLE DIGGER

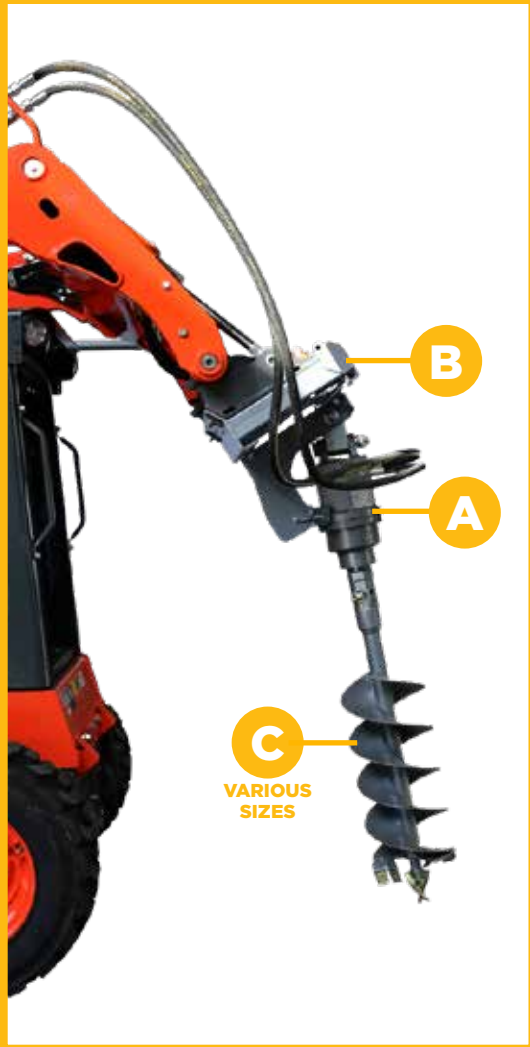

## A SKID STEER POST HOLE DIGGER

**2**  
HYDRAULIC PORTS REQUIRED



THE AUGER DRIVE UNIT LETS YOU DIG PLUMB HOLES WITH SPEED AND PRECISION. THE PLANETARY GEARED DRIVE POWERS THROUGH TOUGH SOIL

**WHEN DIGGING HOLES, TORQUE MEANS POWER!**



**DRIPLESS COUPLERS**

HEX SHAFT  
BE-SSPHD4500

PART #	BE-SSPHD3000	BE-SSPHD4500
TORQUE RANGE	708 - 2122' - LB	1107 - 3319' - LB
MAX PSI	3000 PSI	3000 PSI
OIL FLOW RANGE	7 - 20 GPM	13 - 30 GPM
SPEED RANGE	36 - 100 RPM	42 - 97 RPM
UNIT HEIGHT	26"	26"
UNIT WIDTH	10"	10"
UNIT WEIGHT	157 LBS	166 LBS
MOUNTING FRAME	FIXED CENTRE CRADLE/ SIDE SHIFT CRADLE	FIXED CENTRE CRADLE/ SIDE SHIFT CRADLE
HYDRAULIC PORTS	2	2

- Forged hood ears to cope with the heavy strain of daily use.
- Lockable hood pin makes it almost impossible to accidentally detach from your frame.
- Non-dislodgement shaft guarantees the shaft will never fall out, making for a safer work environment.
- Includes 2 hydraulic hoses

## B SKID STEER POST HOLE DIGGER MOUNT PLATE



PART #	BE-SSPHDMP
FRAME WEIGHT	145 LBS
SLIDE TRAVEL DISTANCE	40"

## C HEX SHAFT AUGERS



PART #	SSA6	SSA9	SSA12	SSA18	SSA24
SIZE	6"	9"	12"	18"	24"

**QUICK HITCHES**

**3 POINT QUICK HITCHES**

**MIX & MATCH & SAVE!**

**BOXED EACH OR CRATED MASTER QUANTITY**

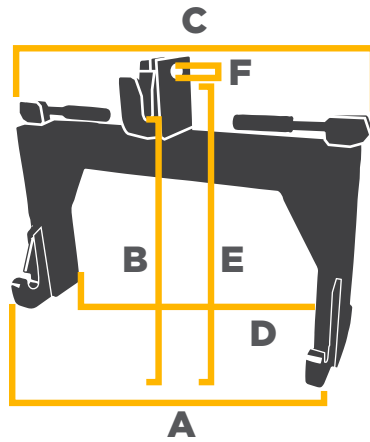

**NEW!**



**TRUE CAT 1 QUICK HITCH**  
**DOES NOT REQUIRE ADAPTER BUSHINGS**

QH1N



QH1G1



QH2G



QH2HDG



QH2-3G



QH3NG



QH3G

PART #	QH1N*	QH1G1**	QH2G	QH2HDG	QH2-3G	QH3NG	QH3G
WEIGHT	72 LBS	72 LBS	139 LBS	163 LBS	197 LBS	176 LBS	184 LBS
WIDTH	29"	29"	36"	36"	42"	37"	42"
MAX HP RATING	50 HP	50 HP	100 HP	130 HP	225 HP	225 HP	225 HP
HITCH	CAT 1	CAT 1	CAT 2	CAT 2	CAT 2-3	CAT 3 NARROW	CAT 3
A	27"	27"	32-3/4"	33"	38"	33-1/2"	38-1/2"
B	17"/20"	17"/20"	18"	17-1/2"	21-3/4"	21-1/4"	21-3/4"
C	30-1/4"	30-1/4"	37-1/2"	38-1/2"	43-1/2"	38"	43-1/2"
D	26-1/2"	26-1/2"	36-3/4"	37-1/2"	36-1/2" / 42-1/2"	37"	42-1/2"
E	20-1/4"	20-1/4"	21"	23-1/4"	26-3/4"	27-1/4"	27"
F	.75"	.75"	1"	1"	1-3/4"	1-3/4"	1-3/4"

\* QH1N INCLUDES TRUE CATEGORY 1 LIFT ARM HOOKS AND DOES NOT REQUIRE AN ADAPTER BUSHING KIT

\*\* QH1G1 INCLUDES REDUCER BUSHING KIT. REPLACEMENT KIT PART # QK1-B

**TOW HITCHES & ACCESSORIES**

**HEAVY DUTY TRAILER MOVER**

PART #	64.500.344
DESCRIPTION	HEAVY DUTY TRAILER MOVER
WEIGHT	72 LBS
CATEGORY	CAT 1 - 2



INCLUDES INTERCHANGEABLE 2-5/16" TRAILER BALL WITH 1" THREADS

**3 POINT TOW HOOK**

CAT 1, TOW HITCH LOWER CONNECTION  
64.500.340Q

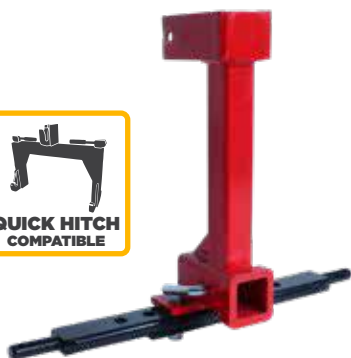

**3 POINT TOW HOOK**

CAT 1, TOW HITCH UPPER & LOWER CONNECTION  
64.500.341Q



**3 POINT TOW HOOK**

CAT 2, HD TOW HITCH UPPER & LOWER CONNECTION  
64.500.343Q



PART #	64.500.340Q	64.500.341Q	64.500.343Q
DESCRIPTION	LOWER CONNECTION TOW HITCH	UPPER & LOWER CONNECTION TOW HITCH	HD UPPER & LOWER CONNECTION TOW HITCH
CATEGORY	CAT 1	CAT 1	CAT 2
WEIGHT	26 LBS	35 LBS	44 LBS



**CONSUMER FRIENDLY RETAIL PACKAGING**



**VARIOUS TRAILER BALLS AVAILABLE**

SEE WEBSITE FOR MORE INFORMATION [BRABEREQ.COM](http://BRABEREQ.COM)





# BALL MOUNT TOW HOOK

CAT 1, TOW HITCH LOWER CONNECTION  
64.500.340B



INCLUDES TRIPLE BALL MOUNT!

# BALL MOUNT TOW HOOK

CAT 1, TOW HITCH UPPER & LOWER CONNECTION  
64.500.341B



INCLUDES TRIPLE BALL MOUNT!

# BALL MOUNT TOW HOOK

CAT 2, HD TOW HITCH UPPER & LOWER CONNECTION  
64.500.343B



INCLUDES TRIPLE BALL MOUNT!

PART #	64.500.340B	64.500.341B	64.500.343B
DESCRIPTION	LOWER CONNECTION TOW HITCH	UPPER & LOWER CONNECTION TOW HITCH	UPPER & LOWER CONNECTION TOW HITCH
CATEGORY	CAT 1	CAT 1	CAT 2



CONSUMER FRIENDLY  
RETAIL PACKAGING



# BUCKET MOUNT RECEIVER

64.500.342

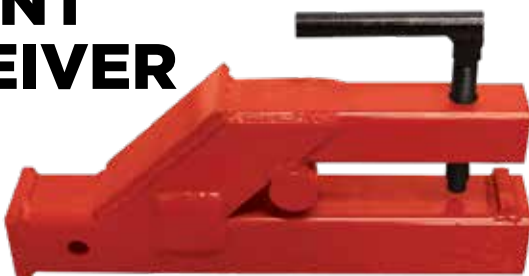

**POST HOLE DIGGERS**

**COMPACT  
TRACTOR  
POST HOLE  
DIGGER**

UP TO 30 HP

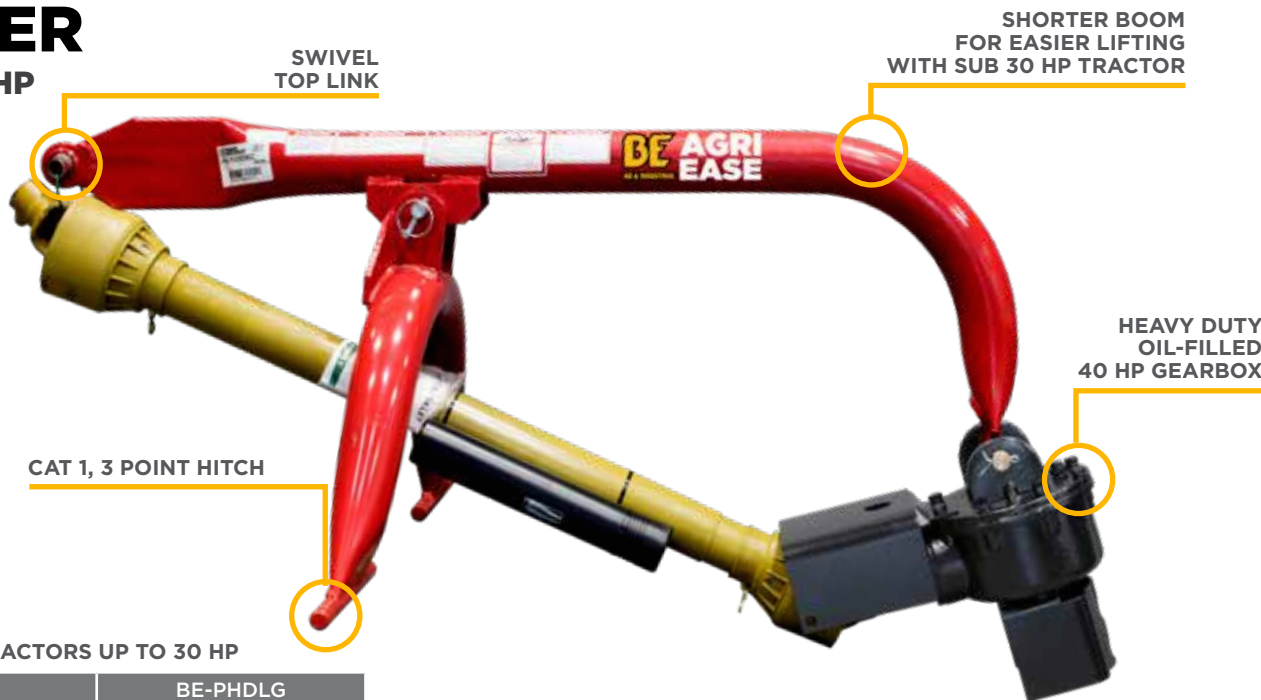

**BUY  
MULTIPLE  
& SAVE  
3%!**

\* IDEAL FOR TRACTORS UP TO 30 HP

PART #	BE-PHDLG
WEIGHT	135 LBS
DRILLING DEPTH	40"
HP RATING	UP TO 30 HP



**AUGERS**

**BOXED  
EACH**

**BOXED INDIVIDUALLY  
SOLD SEPARATELY**



AUGER OPENING



PART #	PHA6SG	PHA9SG	PHA12SG
SIZE	6"	9"	12"
WEIGHT	21 LBS	32 LBS	43 LBS
DRILLING DEPTH	24"	24"	24"

**REPLACEMENT WEAR PARTS**

OUTER CUTTING EDGE	PD-24567-E	PD-24577-E	PD-24587-E
INNER CUTTING EDGE	N/A	PD-24578-E	PD-24588-E

# POST HOLE DIGGER



PART #	BE-PHDG
WEIGHT	155 LBS
DRILLING DEPTH	40"
HP RATING	UP TO 60 HP

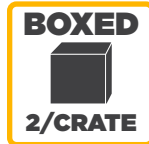

## AUGER

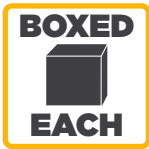

**BOXED INDIVIDUALLY  
SOLD SEPARATELY**



**AUGER OPENING**

PART #	PHA6G	PHA9G	PHA12G
SIZE	6"	9"	12"
WEIGHT	32 LBS	40 LBS	52 LBS
DRILLING DEPTH	40"	40"	40"



### REPLACEMENT WEAR PARTS

OUTER CUTTING EDGE	PD-24567-E	PD-24577-E	PD-24587-E
INNER CUTTING EDGE	N/A	PD-24578-E	PD-24588-E

# STANDARD PLOW

CAT 1, 3 POINT HITCH

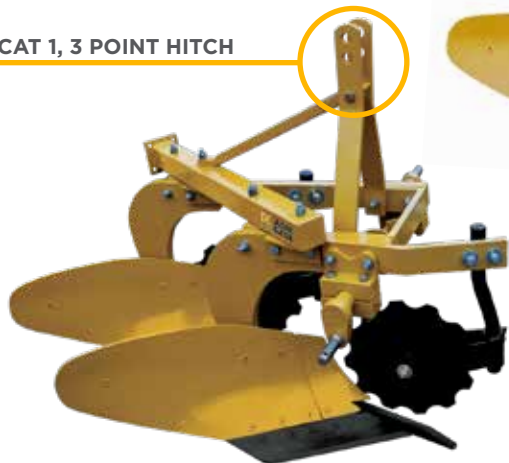

CAT 1, 3 POINT HITCH



CAT 2, 3 POINT HITCH



PART #	BE-P1BFK	BE-P2BFK	BE-P3FK
CATEGORY	1	1	2
WEIGHT	253 LBS	462 LBS	775 LBS
HP RATING	15 - 30 HP	30 - 40 HP	40 - 60 HP
COULTERS	1	2	3

## REPLACEMENT WEAR PARTS

POINT BAR	10320008	10320008	10320008
-----------	----------	----------	----------

# DISC BEDDER

BE-DB2N

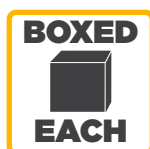

CAT 1, 3 POINT HITCH



HEIGHT  
ADJUSTABLE

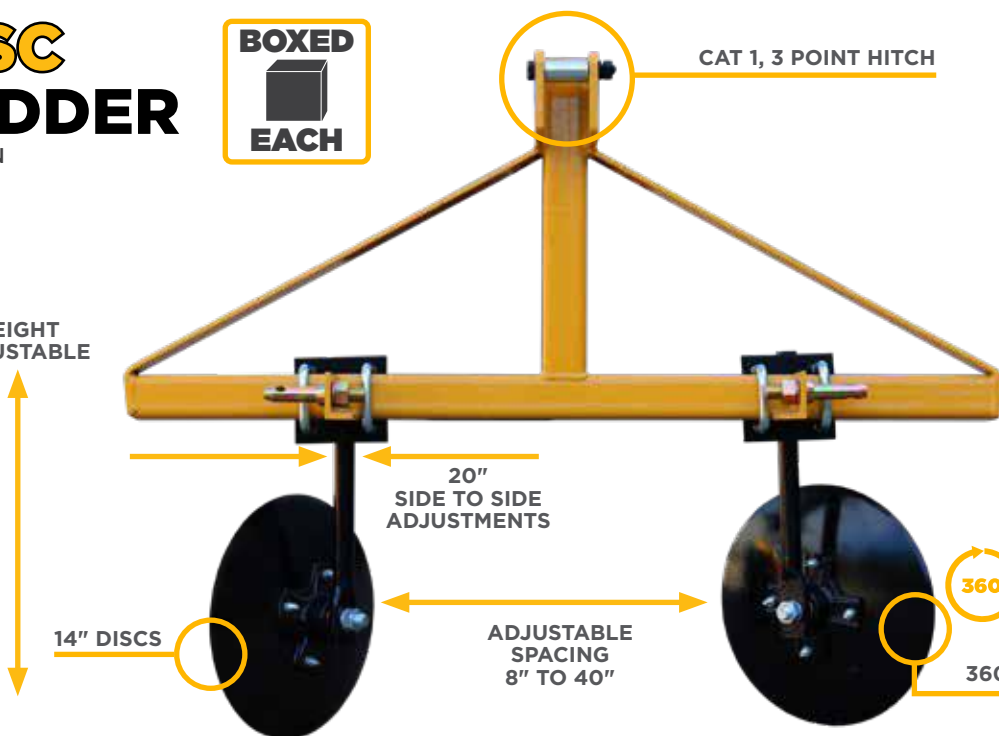

**COMPLETE  
DISC ASSEMBLY**  
106.101B.019



OPTIONAL

360° ROTATION



**STANDARD DUTY DISC HARROW**  
50", 59"

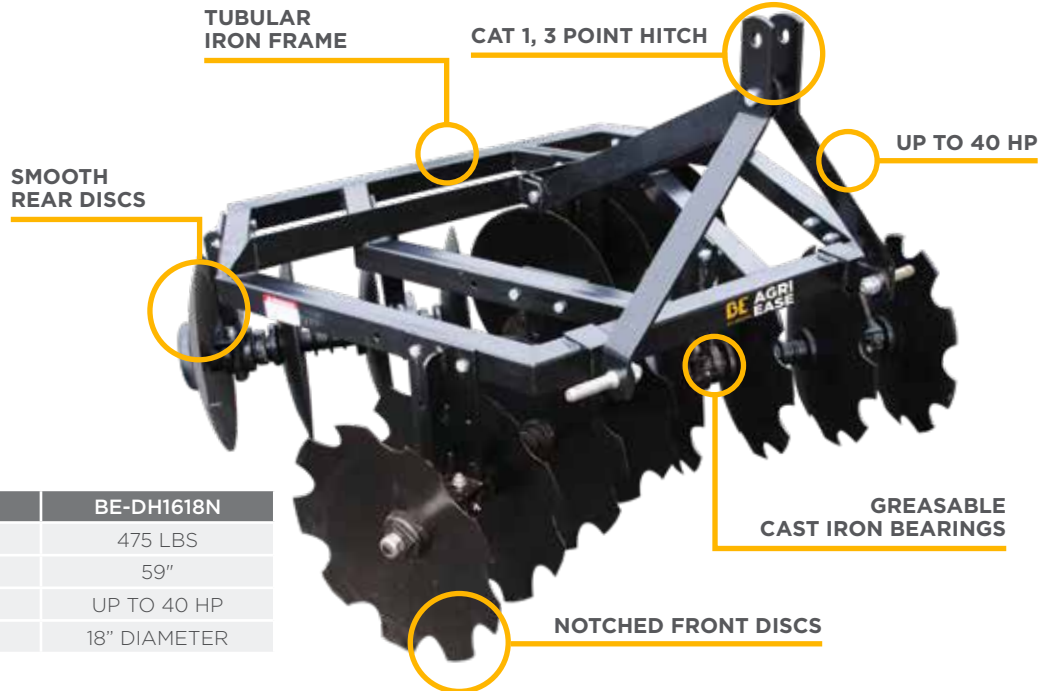

PART #	BE-DH1216N	BE-DH1618N
WEIGHT	410 LBS	475 LBS
CUTTING WIDTH	50"	59"
HP RATING	UP TO 40 HP	UP TO 40 HP
BLADE SIZE	16" DIAMETER	18" DIAMETER

**REPLACEMENT WEAR PARTS**

NOTCHED BLADES	DH5-3.16G	DH5-3.18G
SMOOTH BLADES	DH5-3.16SG	DH5-3.18SG

**HEAVY DUTY DISC HARROW**  
54", 72", 86"

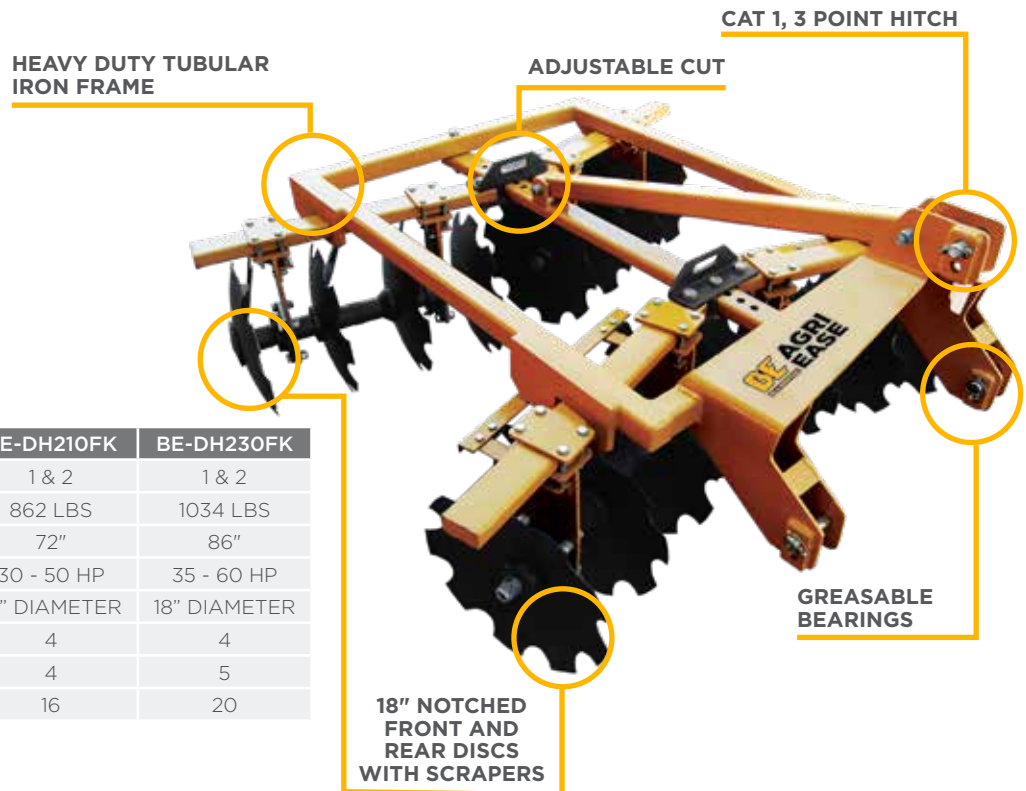

PART #	BE-DH185FK	BE-DH210FK	BE-DH230FK
CATEGORY	1	1 & 2	1 & 2
WEIGHT	590 LBS	862 LBS	1034 LBS
CUTTING WIDTH	54"	72"	86"
HP RATING	20 - 40 HP	30 - 50 HP	35 - 60 HP
BLADE SIZE	18" DIAMETER	18" DIAMETER	18" DIAMETER
GANGS	4	4	4
DISCS PER GANG	3	4	5
TOTAL DISCS	12	16	20

**REPLACEMENT WEAR PARTS**

NOTCHED BLADES	FKTDHL-016	FKTDHL-016	FKTDHL-016
----------------	------------	------------	------------



# 1 ROW CULTIVATOR

WITH SPRING SHANKS  
48"

PART #	BE-FC1RN
WEIGHT	118 LBS
WIDTH	48"
TINES	6

**REPLACEMENT WEAR PARTS**

C-TINE	FC2RG
REVERSIBLE POINT	ART-460

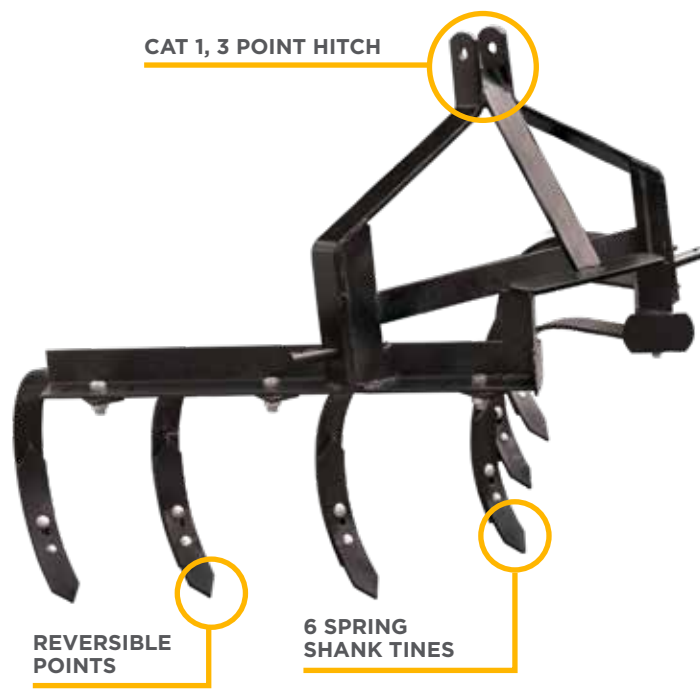

# S-TINE CULTIVATOR

60", 72", 84"

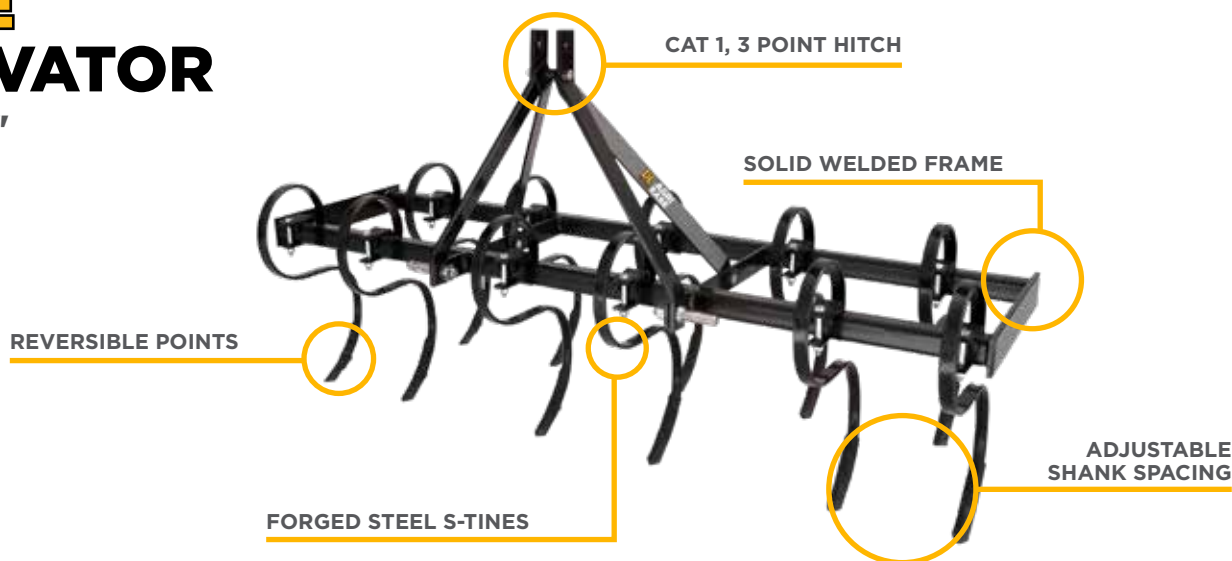

PART #	BE-FC05ST	BE-FC06ST	BE-FC07ST
WEIGHT	185 LBS	210 LBS	240 LBS
WIDTH	60"	72"	84"
S-TINES	9	11	13

**REPLACEMENT WEAR PARTS**

S-TINE	56.000.001	56.000.001	56.000.001
BOLT KIT	56.000.016	56.000.016	56.000.016
REVERSIBLE POINT	56.000.003	56.000.003	56.000.003
TINE CLAMP	56.000.005	56.000.005	56.000.005

# HEAVY DUTY CULTIVATOR

SPRING TINE LOADED  
42", 66", 84", 96"

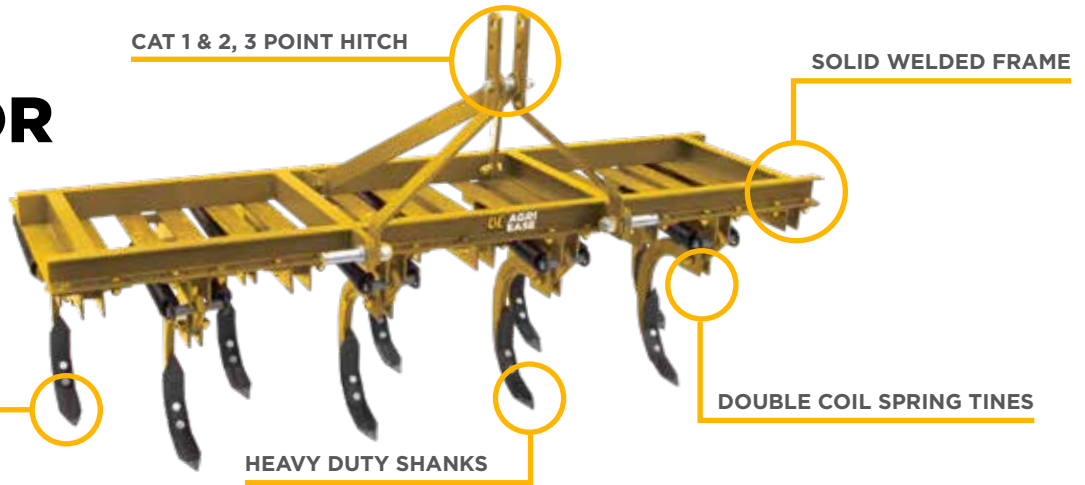

PART #	BE-FC5S	BE-FC7S	BE-FC9S	BE-FC11S
CATEGORY	1	2	2	2
WEIGHT	350 LBS	450 LBS	575 LBS	700 LBS
WIDTH	42"	66"	84"	96"
HP RATING	20 - 40 HP	20 - 40 HP	30 - 50 HP	30 - 50 HP
TINES	5	7	9	11

## REPLACEMENT WEAR PARTS

POINT	10320002	10320002	10320002	10320002
PLOW BOLT	10260137	10260137	10260137	10260137
PLOW NUT	10280033	10280033	10280033	10280033

# CULTIVATOR SOIL CONDITIONER

48", 60", 72"



PART #	BE-FCH04R	BE-FCH05R	BE-FCH06R
WEIGHT	451 LBS	564 LBS	677 LBS
WIDTH	48"	60"	72"
S-TINE	7	9	11

## REPLACEMENT WEAR PARTS

S-TINE	56.000.018	56.000.018	56.000.018
BOLT KIT	56.000.004	56.000.004	56.000.004
SWEEP	56.000.008	56.000.008	56.000.008

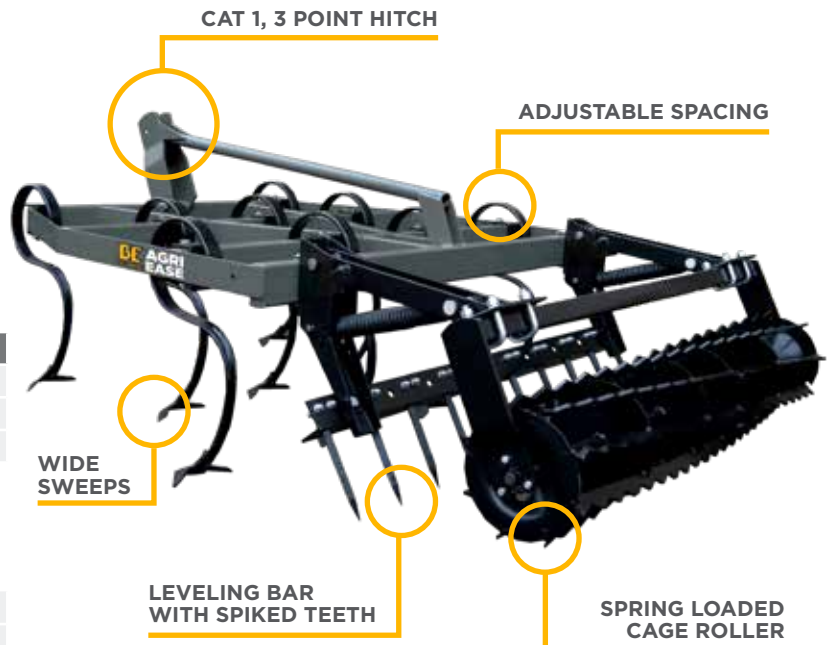

**SUBSOILERS & MIDDLEBUSTERS**

**3 POINT HITCH  
SUBSOILER**

IDEAL FOR DEEP TILLAGE



CAT 1, 3 POINT HITCH



PART #	SS1RN
WEIGHT	98 LBS
WORKING WIDTH	2"
DIGGING DEPTH	ADJUSTABLE: 12" - 22"
HP RATING	UP TO 40 HP

**REPLACEMENT WEAR PARTS**

POINT	SSPOINTG
-------	----------

**3 POINT HITCH  
MIDDLEBUSTER**

IDEAL FOR CREATING FURROWS



CAT 1, 3 POINT HITCH



PART #	MB15N
WEIGHT	110 LBS
WORKING WIDTH	15"
DIGGING DEPTH	ADJUSTABLE: 6" - 8"
HP RATING	UP TO 40 HP

**REPLACEMENT WEAR PARTS**

POINT	MB01G
-------	-------

**SUBSOILER**

2 SHANK REGULAR DUTY  
22"



CAT 2, 3 POINT HITCH

REPLACEABLE POINT

PART #	BE-SS2FK
CATEGORY	2
DEPTH	22"
HP RATING	60 - 75 HP
WEIGHT	450 LBS

**SUBSOILER**

3 SHANK REGULAR DUTY  
22"



CAT 2, 3 POINT HITCH

REPLACEABLE POINT

PART #	BE-SS3FK
CATEGORY	2
DEPTH	22"
HP RATING	80 - 95 HP
WEIGHT	790 LBS

**SUBSOILERS**

**SUBSOILER**

**1 SHANK HEAVY DUTY  
28"**



**SUBSOILER**

**2 SHANK HEAVY DUTY  
28"**



**SUBSOILER**

**3 SHANK HEAVY DUTY  
28"**

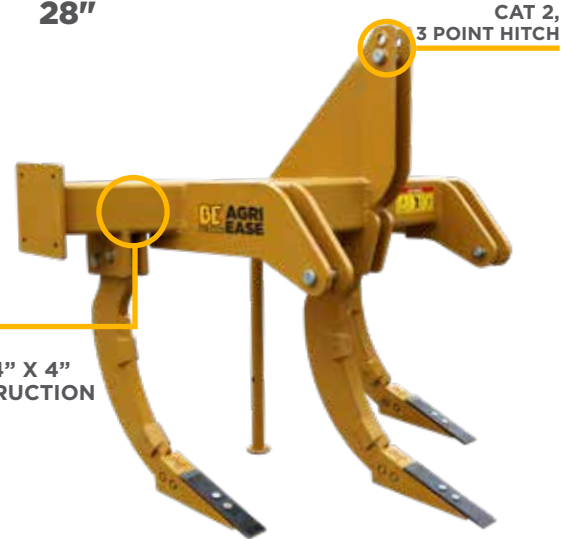

PART #	BE-SS1HDFK	BE-SS2HDFK	BE-SS3HDFK
CATEGORY	2	2	2
DEPTH	28"	28"	28"
WIDTH	31"	48"	60"
HEIGHT	48"	57"	57"
HP RATING	40 - 65 HP	60 - 75 HP	90 - 115 HP
WEIGHT	232 LBS	992 LBS	1147 LBS
TINE SPACING	N/A	27"	21"

**REVERSIBLE SCOOP**

**30"**



PART #	BE-RS30G
WEIGHT	203 LBS
WIDTH	30"
HP RATING	UP TO 40 HP
CAPACITY	10 FT <sup>3</sup> / 0.28M <sup>3</sup>

# MINI EXCAVATOR

**30"**

PART #	BE-EXC70
ENGINE	KOHLER 395 CC / 9.5 HP
WEIGHT	1808 LBS
WORKING WIDTH	30"
BUCKET VOLUME	18 L / 1098 IN <sup>3</sup>
TRAVEL SPEED	1 MPH
PACKING SIZE	83" X 30" X 88"

OPERATION RANGE	
A: MAX DIGGING HEIGHT	89"
B: MAX DUMPING HEIGHT	60"
C: MAX DIGGING DEPTH	51.5"
D: MAX VERTICAL DIGGING DEPTH	39.5"
E: MAX DIGGING DISTANCE	102"
F: MAX HORIZONTAL DISTANCE	98.5"
G: MIN TURNING RADIUS	50"
H: MAX HEIGHT AT MIN ROTATION RADIUS	71"
I: MAX LIFT OF DOZER	7"
J: MAX DEPTH OF DOZER	7.5"

## OPTIONAL ATTACHMENTS

PART #	BE-XFM47
DESCRIPTION	EXCAVATOR FLAIL MOWER HEAD
CUTTING WIDTH	47"
WEIGHT	672 LBS
HAMMERS	18
HYDRAULIC FLOW	60-80 L/MIN
PRESSURE	20MPA
ROTOR DIAMETER	4-1/4"
ROTOR DIRECTION	ONE WAY
DRIVE TYPE	BELT
COUPLING REQUIREMENTS	OIL-IN, OIL-OUT, DRAIN-PORT

## REPLACEMENT WEAR PARTS

BELT	104.104D.058
HAMMER	104.104D.034
BOLT	104.104D.036
LOCK NUT	104.104D.035
ADAPTER PLATE	104.104D.053
TENSION PLATE	104.104D.054

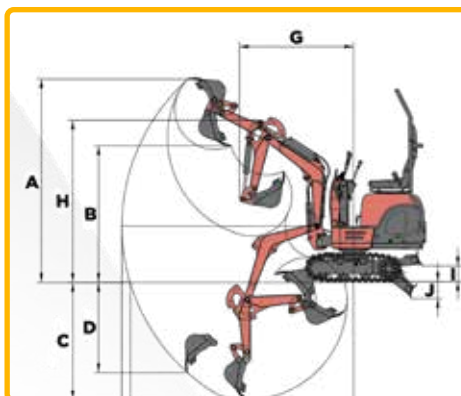

## KOHLER ENGINE

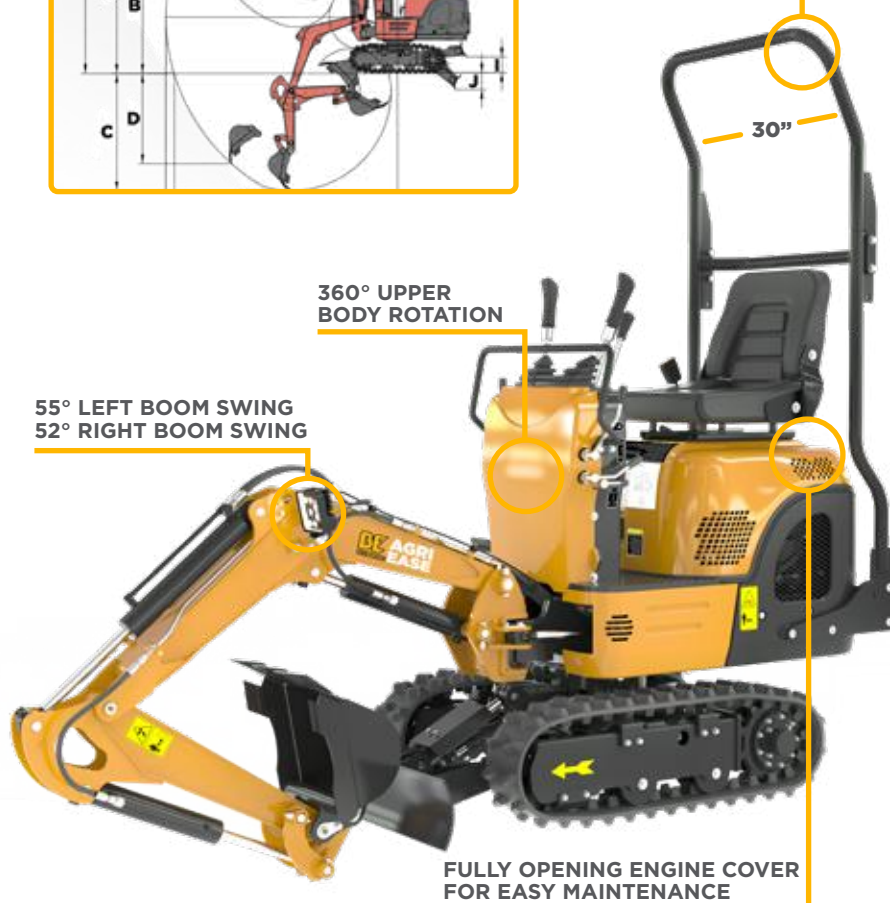
**30" COMPACT WIDTH**



**BACKHOE**

73", 90"



**2**  
HYDRAULIC  
PORTS  
REQUIRED



PIONEER  
TYPE  
COUPLERS



INCLUDES  
BK12 &  
BKPAD



CAT 1 & 2, 3 POINT HITCH

MODEL		BE-BK61	BE-BK71
DIGGING DEPTH (2' FLAT BOTTOM)	A	6'1"	7'6"
REACH FROM CENTER LINE OF SWING PIVOT	B	9'3"	10'9"
LOADING HEIGHT (BUCKET AT 60°)	C	5'3"	6'8"
MAXIMUM LEVELING ANGLE	D	10°	10°
SWING ARC	E	180°	180°
TRANSPORT HEIGHT (MAXIMUM)	F	6'2"	6'4"
TRANSPORT OVERHANG	G	3'8"	4'4"
BUCKET ROTATION	H	180°	180°
STABILIZER SPREAD (DOWN POSITION)	I	5'8"	5'8"
STABILIZER SPREAD (UP POSITION)	J	4'4"	4'4"
ANGLE OF DEPARTURE	K	21°	21°
SHIPPING WEIGHT		948 LBS	1020 LBS
BUCKET DIGGING FORCE		2315 LBS	2600 LBS
DIPPER STICK DIGGING FORCE		1543 LBS	1900 LBS
OPERATING PRESSURE		2300 PSI	2300 PSI
HP RATING		20 - 50 HP	40 - 100 HP
HYDRAULIC FLOW RATE		MIN 6	MIN 6

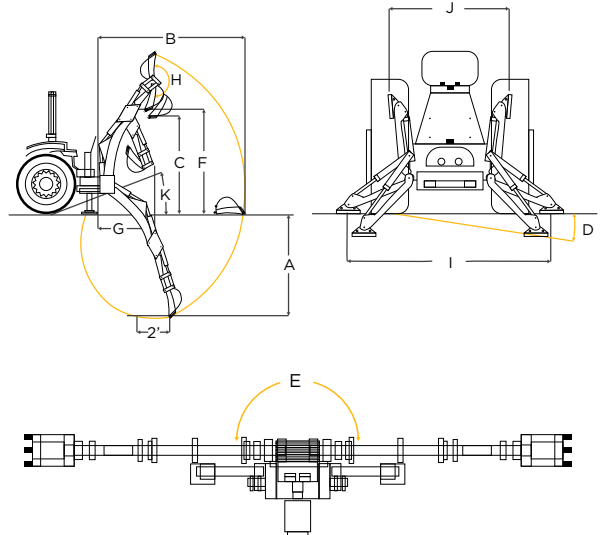

**OPTIONAL BUCKET ACCESSORIES**

PART #	DESCRIPTION
BKHYDKIT	TANK, PUMP & GEARBOX (DEALER INSTALLED OPTION ONLY)
BKPAD*	RUBBER PAD
BK8	8" BUCKET
BK12*	12" BUCKET
BK16	16" BUCKET
BKSTB	RIGID STABILIZER MOUNT
BKTHUMB	MECHANICAL THUMB

\*SWB FRAME KIT MAY BE REQUIRED FOR SOME MODELS

**BKSTB STABILIZER KIT**



\* INCLUDED

**CHAIN HARROWS**

**HARROW**

**WITH POLE**  
48", 72", 96", 120", 144"

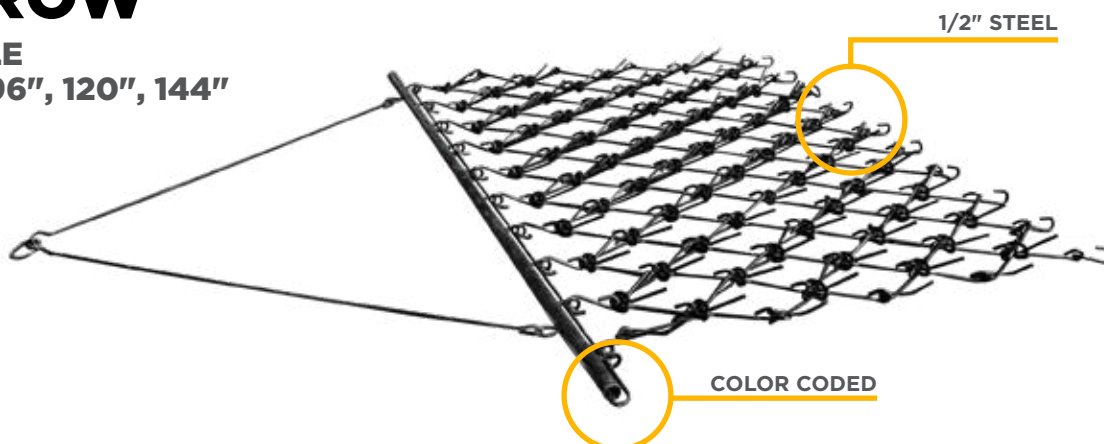

PART #	BE-CH4G	BE-CH6G	BE-CH8G	BE-CH10G	BE-CH12G
WEIGHT	100 LBS	166 LBS	287 LBS	375 LBS	375 LBS
SECTION WIDTH	48"	72"	96"	120"	144"
POLE COLOR CODE	WHITE	BLACK	GREY	RED	YELLOW
BED LENGTH	60"	60"	60"	60"	60"

**REPLACEMENT WEAR PARTS**

PART #	BE-CH4G	BE-CH6G	BE-CH8G	BE-CH10G	BE-CH12G
HOOK BAR	CH122	CH122	CH122	CH122	CH122
POLE ASSEMBLY	CH4G-PA	CH6G-PA	CH8G-PA	CH10G-PA	CH12G-PA
BLANKET HOOK	CH127	CH127	CH127	CH127	CH127

**SUPER  
HEAVY  
DUTY  
CHAIN  
HARROW**

84", 108", 132", 156", 180"

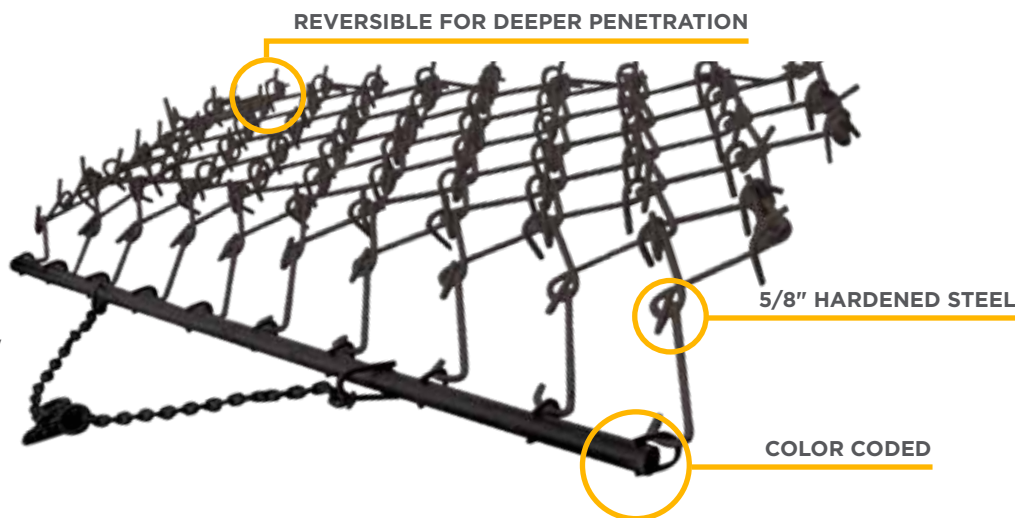

PART #	BE-CH7G	BE-CH9G	BE-CH11G	BE-CH13G	BE-CH15G
WEIGHT	210 LBS	276 LBS	347 LBS	415 LBS	479 LBS
TINES	5/8" (2 SIDED)	5/8" (2 SIDED)	5/8" (2 SIDED)	5/8" (2 SIDED)	5/8" (2 SIDED)
SECTION WIDTH	84"	108"	132"	156"	180"
POLE COLOR CODE	GREY	ORANGE	YELLOW	BLUE	GREEN
BED LENGTH	86"	86"	86"	86"	86"

**REPLACEMENT WEAR PARTS**

POLE ASSEMBLY	BE-PCH7G	BE-PCH9G	BE-PCH11G	CH13G-PA	CH15G-PA
---------------	----------	----------	-----------	----------	----------

# 3 POINT HARROW CARRIER

72"

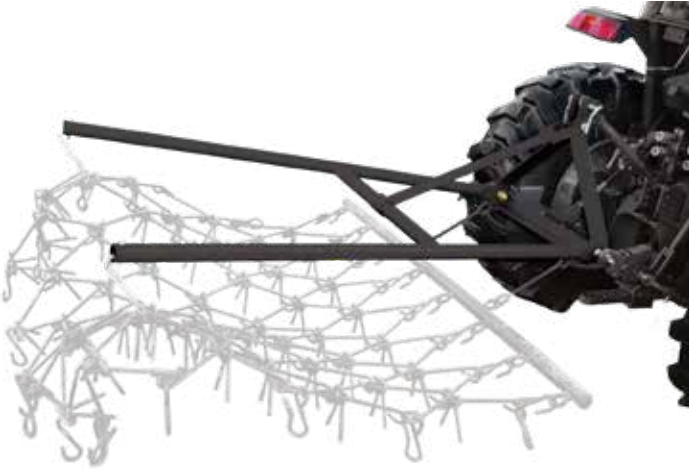

PART #	BE-6LHC
WEIGHT	115 LBS
DESCRIPTION	CARRY UP TO 10' CHAIN HARROWS
DEPTH	72"

\*DOES NOT INCLUDE CHAIN HARROW

# HEAVY DUTY DIAMOND HORSE ARENA HARROWS

40", 60"

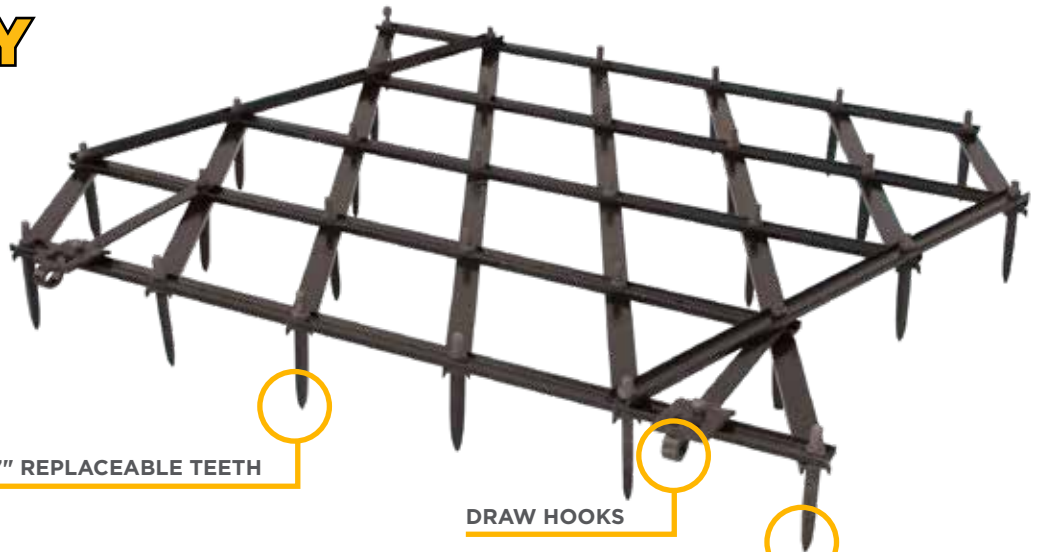

5/8" X 7" REPLACEABLE TEETH

DRAW HOOKS

DROP FORGED  
HEAVY DUTY  
5/8" X 7" SPIKES

PART #	HAR40S	HAR60S
WEIGHT	62 LBS	98 LBS
WORKING WIDTH	40"	60"
LENGTH	52"	52"

## REPLACEMENT WEAR PARTS

DRAW HOOK	61.200.010	61.200.010
TINES	61.200.002	61.200.002



**CONSUMER FRIENDLY  
RETAIL PACKAGING**



# PASTURE HARROW

**4 WAY DUTCH CAST HARROW**  
72", 96", 120", 144", 168", 192"

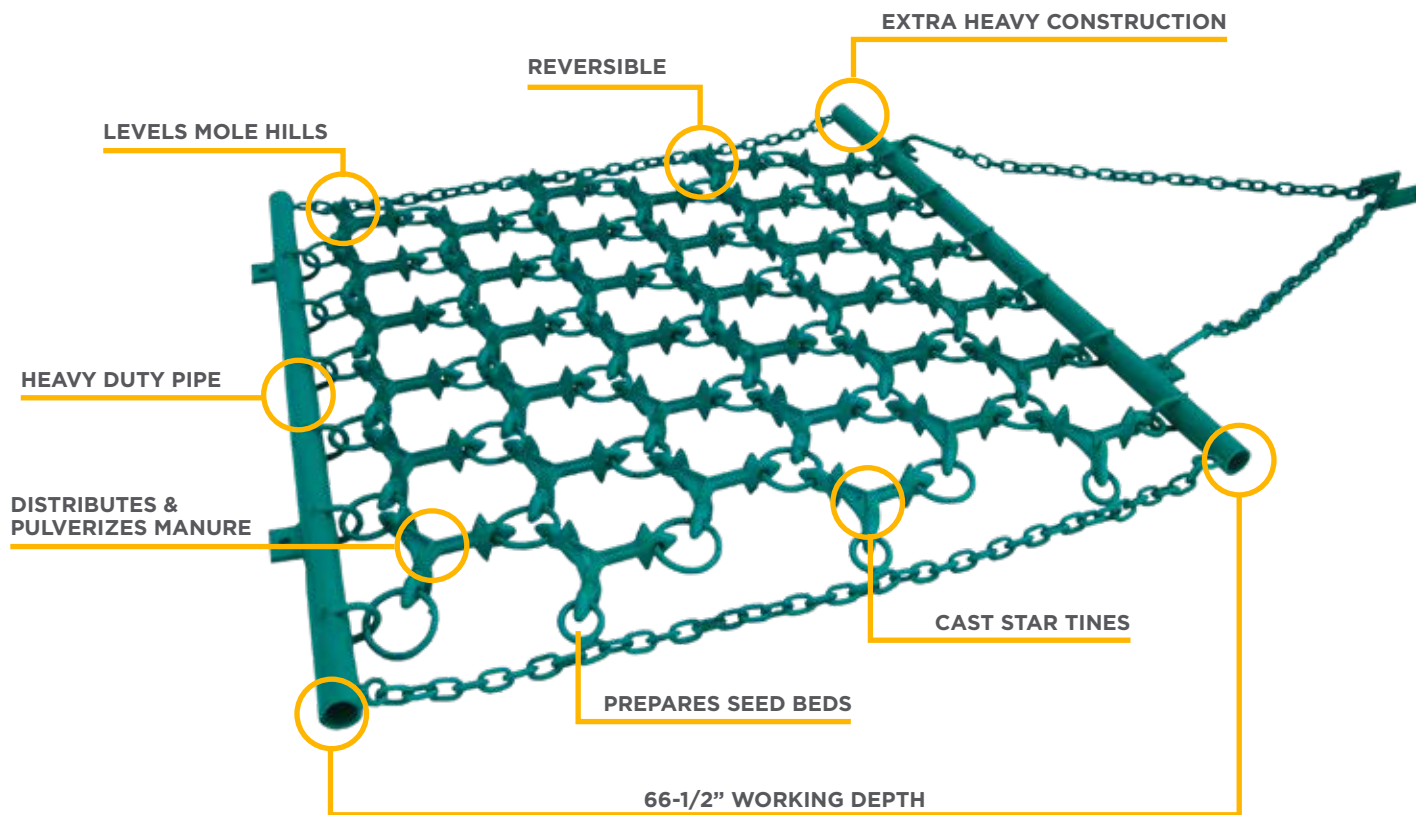

PART #	BE-PH06FT	BE-PH08FT	BE-PH10FT	BE-PH12FT	BE-PH14FT	BE-PH16FT
WEIGHT	297 LBS	396 LBS	495 LBS	594 LBS	643 LBS	693 LBS
WORK WIDTH	72"	96"	120"	144"	168"	192"
POLE COLOR CODE	BLACK	GREY	ORANGE	YELLOW	BLUE	GREEN

## REPLACEMENT WEAR PARTS

STAR TINE	61.000.001	61.000.001	61.000.001	61.000.001	61.000.001	61.000.001
4" MOUNT RING	61.000.002	61.000.002	61.000.002	61.000.002	61.000.002	61.000.002
2" MOUNT RING	61.000.003	61.000.003	61.000.003	61.000.003	61.000.003	61.000.003

**SPIN SPREADER**

550 LB - 1160 LB CAPACITY



BE-PFS250G



BE-PFS400G



NEW HEAVY DUTY POLY HOPPER

MANUAL CONTROLS

540 RPM GEARBOX

CAT 1, 3 POINT HITCH

STAINLESS STEEL DISC & VANES

BOTTOM DROP SPINNER

BE-PFS500G



PART #	BE-PFS250G	BE-PFS400G	BE-PFS500G
WEIGHT	120 LBS	124 LBS	140 LBS
CAPACITY*	550 LBS	750 LBS	1160 LBS

\*CAPACITY VARIES WITH MATERIAL

**OPTIONAL AGITATOR**  
BE-AGI





# MANURE SPREADER

400 LBS



GREASABLE WHEEL HUBS



ADJUSTABLE CHAIN TENSIONER



8 REPLACEABLE BEATER PADDLES



2 WHEEL GROUND DRIVEN



ADJUSTABLE HITCH



GOLD ZINC PLATE CHAIN

<b>PART #</b>	<b>BE-23MS</b>
WEIGHT WITH TIRES	400 LBS
LOAD CAPACITY	29 FT <sup>3</sup>
DIMENSIONS	77" X 28" X 16.7"

- 18" Steel beater with 8 replaceable paddles
- High density poly vinyl 3/4" apron bed
- Two wheel ground driven
- 5/16" T-Rod gold zinc plated apron chain
- Transport end gate
- Industrial powder coating
- 27-1/2" Loading height

# MANURE SPREADER

550 LBS

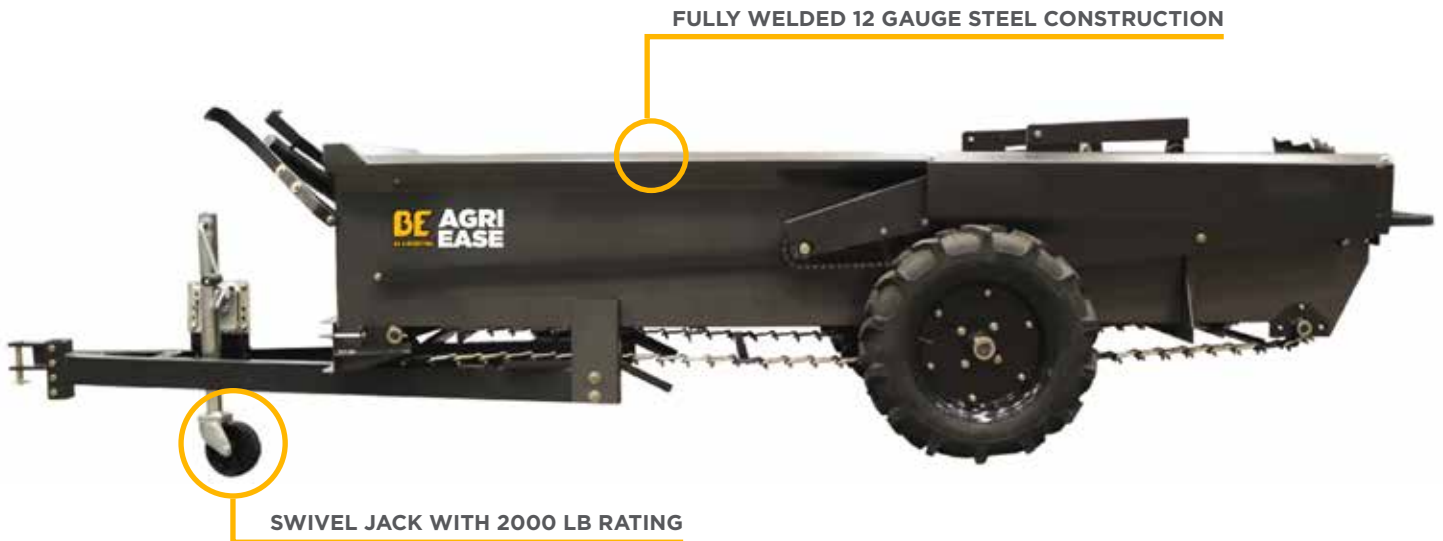

**GREASABLE WHEEL HUBS**



**ADJUSTABLE CHAIN TENSIONER**



**8 REPLACEABLE BEATER PADDLES**



**2 WHEEL GROUND DRIVEN**



**ADJUSTABLE HITCH**



**GOLD ZINC PLATE CHAIN**

PART #	BE-32MS
WEIGHT WITH TIRES	550 LBS
LOAD CAPACITY	40 FT <sup>3</sup>
DIMENSIONS	101" X 28" X 16.7"

- 18" Steel beater with 8 replaceable paddles
- High density poly vinyl 3/4" apron bed
- Two wheel ground driven
- 5/16" T-Rod gold zinc plated apron chain
- Transport end gate
- Industrial powder coating
- 27-1/2" Loading height

**PORTABLE SPRAYERS**

**34 LITER / 9 GALLON SPOT SPRAYER**

90.700.100



NOZZLE ADJUSTS FROM MIST TO SOLID STREAM

TRIGGER GUN WITH 20" CHROME LANCE

**34 LITER / 9 GALLON LITHIUM ION TURF SPRAYER**

90.709.014



EASY TO REACH LIGHTED POWER SWITCH

ADJUSTABLE HANDLE FOR PULL SPRAYING & EASY STORAGE

WIRE BRAIDED NYLON HOSE

SINGLE BROADCAST DEFLECTOR NOZZLE WITH 50' SWATH

12" NEVER FLAT, HEAVY DUTY WHEELS

14.4 VOLT LITHIUM ION BATTERY FOR LONG LASTING POWER



REMOVABLE BAR FOR TOWING BEHIND ATV OR RIDE ONS



1.0 GPM EVERFLO PUMP FOR CONTINUOUS FLOW



# 15 & 25 GALLON SPOT SPRAYERS

15' HOSE WITH U45050000 GUN,  
1.0 GPM 12 VOLT PUMP



**MIX & MATCH & SAVE!**

MOUNTING STRAP GROOVES

SPRAY GUN WITH 15' HOSE

MOLDED WAND CLIPS

## OPTIONAL ACCESSORIES



90.700.302



90.700.303



90.700.304

PART #	90.700.150	90.700.250
CAPACITY	15 GALLON	25 GALLON
PUMP	DELVAN 1.0 GPM, 12V	DELVAN 1.0 GPM, 12V

### REPLACEMENT WEAR PARTS

PUMP	90.220.201	90.220.201
------	------------	------------

### OPTIONAL ACCESSORIES

PART#	DESCRIPTION
90.700.302	7' COVERAGE BOOM, 2 NOZZLES. USE WITH A MINIMUM 1.8 GPM PUMP*
90.700.303	BRACKET KIT FOR ATV, SINGLE
90.700.304	10' COVERAGE FOLDING BOOM, 3 NOZZLES. USE WITH A MINIMUM 1.8 GPM PUMP*

# 15 GALLON REPLACEMENT TANK

90.700.155



**SPOT & ATV MOUNT SPRAYERS**

**25 GALLON  
ATV SPRAYER**

INCLUDES TANK, ATV MOUNT & BOOM



PART #	90.712.250	90.713.250
CAPACITY	25 GALLON	25 GALLON
BOOM	2 NOZZLE FIXED	3 NOZZLE FOLDING
BOOM SPRAY COVERAGE	7'	10'

- 5" Fill lid with tether
- Glyphosate compatible
- Adjustable flow control & pressure gauge
- Adjustable pressure with return to tank
- Adjustable brackets for perfect boom height
- Adjustable cone spray nozzle
- 1 year warranty on manufacturing defects on pump and components

**REPLACEMENT WEAR PARTS**

PUMP	90.241.220	90.241.220
------	------------	------------



**15 & 25  
GALLON  
TRAILER  
SPRAYER**



7' BOOM SPRAY COVERAGE

**MIX & MATCH & SAVE!**

**BUNA SEALS**

**7' BOOM SPRAY COVERAGE**

**OPTIONAL SPRAY BOOMS**



90.700.304

90.700.314

90.700.306

90.700.307

<b>PART #</b>	90.800.150	90.800.250
<b>CAPACITY</b>	15 GALLON	25 GALLON

**REPLACEMENT WEAR PARTS**

<b>PUMP</b>	90.780.230	90.241.220
-------------	------------	------------

**OPTIONAL SPRAY BOOMS**

<b>PART#</b>	<b>DESCRIPTION</b>
90.700.304	FOLDING BOOM KIT, 10' COVERAGE 3 NOZZLE
90.700.314	FOLDING BOOM, 4 NOZZLES, 14' COVERAGE USE WITH MINIMUM 3 GPM PUMP
90.700.306	BOOMLESS NOZZLE KIT, SINGLE
90.700.307	BOOMLESS NOZZLE KIT, DOUBLE



# 40 GALLON TRAILER SPRAYER



**ALL MODELS INCLUDE:**

**PUMP  
FLOW CONTROL VALVE  
SPOT GUN  
& BOOM**



PART #	90.800.400
CAPACITY	40 GALLON
BOOM SPRAY COVERAGE	10'

- On-Off boom control
- Adjustable pressure with return to tank
- Glyphosate compatible

**REPLACEMENT WEAR PARTS**

PUMP	90.241.220
REPLACEMENT TIP	90.140.025

# 40 GALLON 3 POINT SPRAYERS

**ALL MODELS INCLUDE:  
PUMP FLOW  
CONTROL VALVE  
SPOT GUN & BOOM**



PRESSURE  
CONTROL & GAUGE

HANDGUN  
WITH 15' HOSE

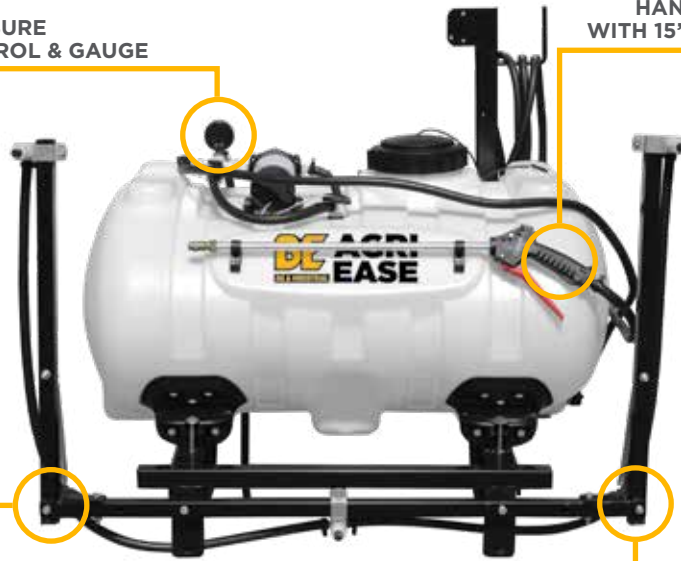

3 POINT FRAME

FOLDING BOOM SPRAYER  
WITH 10' SPRAY COVERAGE

PART #	BE-RMES40	BE-RMS40
CAPACITY	40 GALLON	40 GALLON
PUMP	12V PUMP	ROLLER PUMP

## REPLACEMENT PARTS

PUMP	90.240.220	6900C
------	------------	-------

# 60 GALLON 3 POINT SPRAYERS

**ALL MODELS INCLUDE:  
PUMP FLOW  
CONTROL VALVE  
SPOT GUN & BOOM**



PRESSURE CONTROL & GAUGE

HANDGUN  
WITH 15' HOSE



3 POINT FRAME

3 SECTION, 3 NOZZLE FOLDING  
BOOM WITH 10' SPRAY COVERAGE

PART #	BE-RMES60	BE-RMS60
CAPACITY	60 GALLON	60 GALLON
PUMP	12V PUMP	ROLLER PUMP

## REPLACEMENT WEAR PARTS

PUMP	90.240.220	6900C
------	------------	-------

# 40 & 60 GALLON RTV MOUNT SPRAYER

WITH BOOM AND SPOT WAND

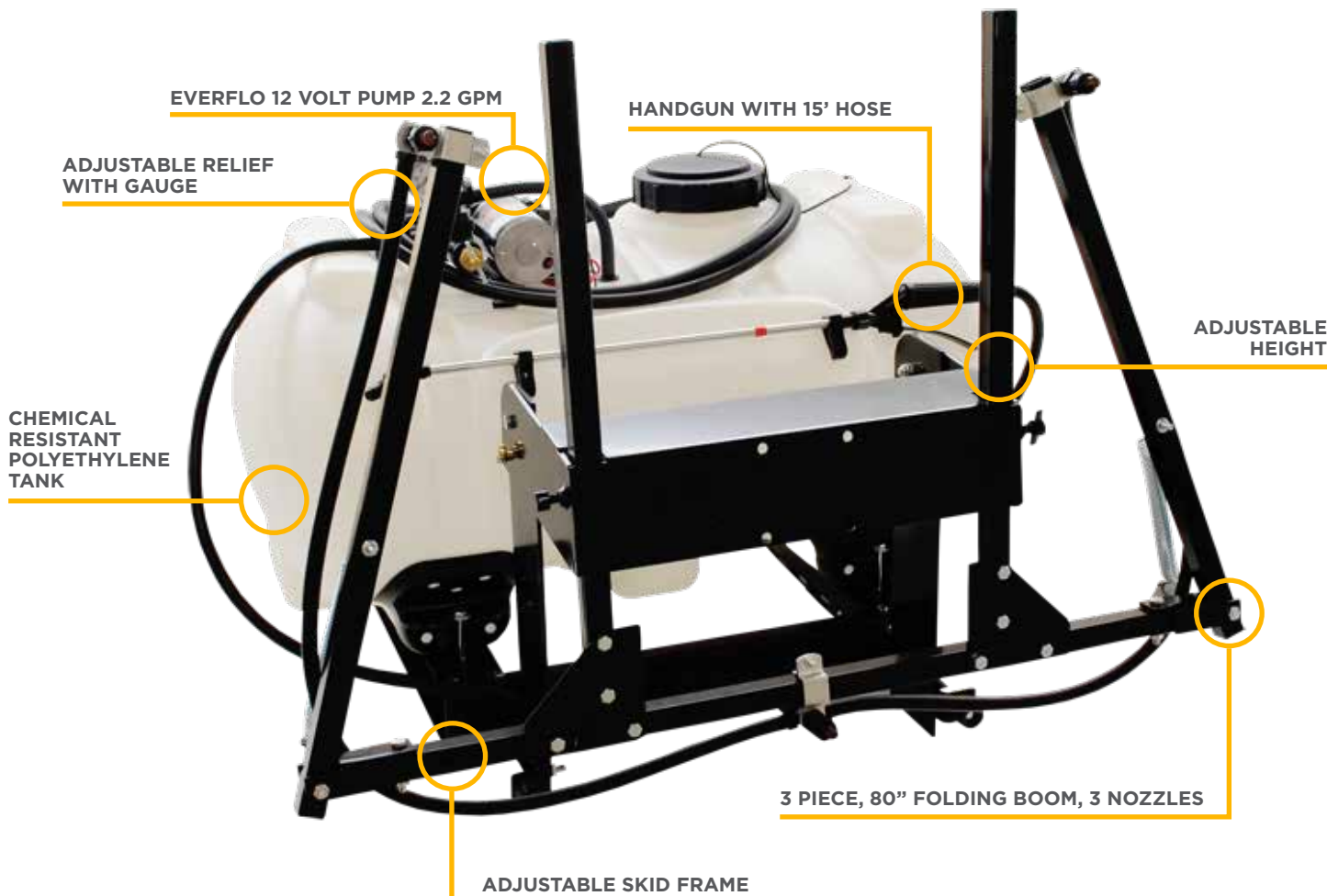



**BUNA  
SEALS**



**RTV  
MOUNT**



**MINOR  
ASSEMBLY**

PART #	BE-RTVMS40	BE-RTVMS60
CAPACITY	40 GALLON	60 GALLON
PUMP	EVERFLO 12V	EVERFLO 12V

**REPLACEMENT WEAR PARTS**

PUMP	90.240.220	90.240.220
------	------------	------------

- 2.2 GPM / 8.3 LPM, 70 PSI / 4.5 Bars
- Fits most RTV boxes
- Includes remote switch
- Rubber bumpers ensure a snug fit over the RTV tailgate to minimize sliding in box

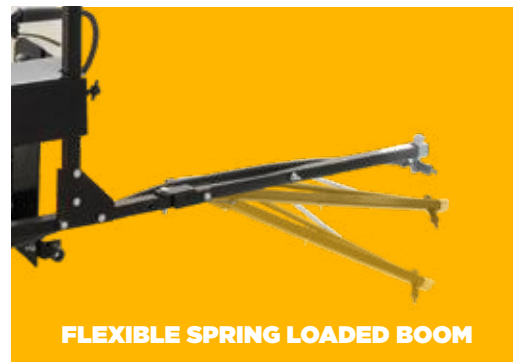

# 150 GALLON 3 POINT SPRAYER

INCLUDES 23' BOOM



PART #	BE-RMS150-23FB	BE-RMS200-23FB
WEIGHT	305 LBS	425 LBS
CAPACITY	150 GALLON	200 GALLON
BOOM	23'	23'
# OF NOZZLES	14	14
PUMP	6900C ROLLER PUMP INCLUDED COMPLETE WITH COUPLER AND TORQUE BAR	

- Cat 1, 2; 3 Point hitch
- 8 way selector valve
- In-line strainer
- Round Up ready
- No-drip fan nozzles
- Quick exchange nozzle bodies



**SKID MOUNT SPRAYERS**

**40 & 60 GALLON SKID MOUNT SPRAYER**



PART #	BE-SMSE40-10	BE-SMSE60-10
CAPACITY	40 GALLON	60 GALLON
PUMP	1.8 GPM 12V	2.0 GPM 12V

**REPLACEMENT WEAR PARTS**

PUMP	90.543.936	90.240.220
------	------------	------------

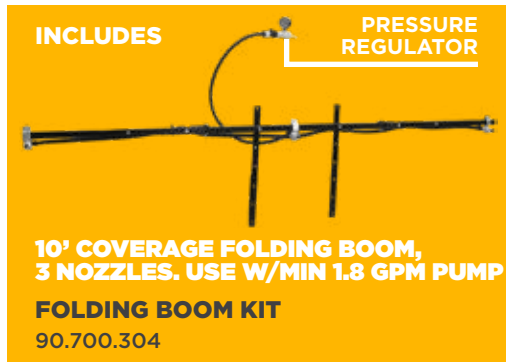

**SKID MOUNT SPRAYER TANKS**

100, 150, 200 GALLON



INCLUDES 40" X 18" ACCESSORY MOUNTING PLATE

SKID SIZE: 70" X 40" X 5"

PART #	BE-SMS100	BE-SMS150	BE-SMS200
CAPACITY	100 GALLON	150 GALLON	200 GALLON

**SKID MOUNT SPRAYERS**

150 & 200 GALLON

COMES ASSEMBLED!

AR30 PUMP

300', 3/8" HOSE



SKID SIZE: 70" X 40" X 5"



BlueFlex

INCLUDES 90.800.005 6.5 HP GX200 HONDA ENGINE & AR 30 PUMP



PART #	BE-SMS150AR30GX	BE-SMS200AR30GX
CAPACITY	150 GALLON	200 GALLON

- Includes filter, fittings, & agitator kit
- Includes 90.300.002 spray gun

POWERED by **HONDA**

**PORTABLE SPOT SPRAYERS**

**400 LITER /  
105 GALLON  
PORTABLE  
SPRAYER**

WITH TANK & 12V PUMP



<b>PART #</b>	<b>90.870.400</b>
CAPACITY	400 LITER / 105 GALLON
PUMP	12 V
MAX PSI	100 PSI @ 2.55 GPM
MAX GPM	7 GPM @ 10 PSI

**REPLACEMENT WEAR PARTS**

PUMP	90.787.111
SPRAY GUN	U45050006
GAUGE	85.300.100

**OPTIONS**

SEE OUR FULL RANGE OF RATCHET STRAPS AT [BRABEREQ.COM](http://BRABEREQ.COM)



**400 LITER /  
105 GALLON  
PORTABLE  
SPRAYER**

WITH TANK & AR PUMP

POWERED by  
**HONDA™**

HAND GUN WITH  
150' HOSE & HOSE REEL

AR30 PUMP  
WITH 196 CC HONDA  
GX200 ENGINE

TIE-DOWN INSERTS



**BE AGRI EASE**  
AG & INDUSTRIAL



**BlueFlex**

INCLUDES 90.800.005  
6.5 HP GX200 HONDA ENGINE & AR 30 PUMP



PALLET FORK INSERTS



PART #	90.830.400
CAPACITY	400 LITER / 105 GALLON
PUMP	AR30
ENGINE	HONDA GX200 196 CC / 6.5 HP

**REPLACEMENT WEAR PARTS**

PUMP	90.100.030
SPRAY GUN	90.300.002

**OPTIONS**

SEE OUR FULL RANGE OF  
RATCHET STRAPS AT  
**BRABEREQ.COM**





**PORTABLE SPOT SPRAYERS**

POWERED by **HONDA**™

**400 LITER / 105 GALLON PORTABLE FIRE SUPPRESSION TANK**

**NEW!**

196 CC HONDA GX200

50 FT HOSE

FAN OR JET SPRAY PATTERN

TIE-DOWN INSERTS



PALLET FORK INSERTS



PART #	90.895.400
CAPACITY	400 LITER / 105 GALLON
PUMP	HP-2065HR
ENGINE	HONDA GX200 196 CC / 6.5 HP
MAX GPM	126 GPM

**REPLACEMENT WEAR PARTS**

FIRE NOZZLE	50.015.002
PUMP SEAL KIT	85.571.143
PUMP PLUG KIT	85.571.144

**OPTIONS**

SEE OUR FULL RANGE OF RATCHET STRAPS AT

**BRABEREQ.COM**





### 3 POINT BOOM SPRAYERS

**MADE IN ITALY**  
**200 LITER /**  
**53 US GALLON**



SPECS	FLO-SS200NB
HP	30
CAPACITY	200 L / 53 US GAL
WEIGHT	187 LBS
PUMP	COMET BP75
OPERATING PSI	0 - 290
LOW PRESSURE CONTROL UNIT	4 VALVE AR1314
FILTER	YES
EXTERNAL TANK LEVEL GAUGE	YES
TANK EMPTY VALVE	YES
SPRAY GUN	YES
HOSE LENGTH	48'

**MADE IN ITALY**  
**400 LITER /**  
**105 US GALLON**



SPECS	FLO-SS400NB
HP	35
CAPACITY	400 L / 105 US GAL
WEIGHT	220 LBS
PUMP	COMET BP75
OPERATING PSI	0 - 290
LOW PRESSURE CONTROL UNIT	4 VALVE AR1314
FILTER	YES
EXTERNAL TANK LEVEL GAUGE	YES
TANK EMPTY VALVE	YES
SPRAY GUN	YES
HOSE LENGTH	48'

**MADE IN ITALY**  
**15' FOLDING BOOM**

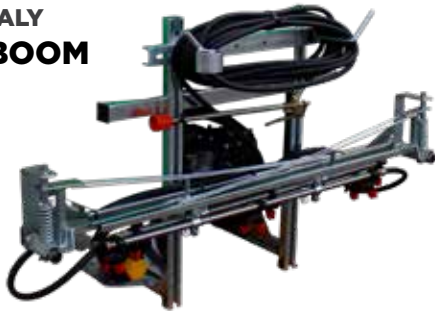

PART #	FLO-4.5MHKIT
NOZZLE TYPE	110° FLAT FAN
# OF NOZZLES	9
BOOM LENGTH	15'

**MADE IN ITALY**  
**20' FOLDING BOOM**



PART #	FLO-6MKIT
NOZZLE TYPE	110° FLAT FAN
# OF NOZZLES	12
BOOM LENGTH	20'



**ORDER THE SPRAYER SIZE AND BOOM LENGTH TO FIT YOUR APPLICATION**

**SPRAYERS AND BOOM KITS SOLD SEPARATELY.**  
PLEASE REFER TO THE CHART ON THE NEXT PAGE FOR POSSIBLE SPRAYER COMBINATIONS

### 3 POINT BOOM SPRAYERS

**MADE IN ITALY**  
**600 LITER /**  
**158 US GALLON**



SPECS	FLO-SS600NB
HP	40
CAPACITY	600 L / 158 US GAL
WEIGHT	309 LBS
PUMP	COMET BP75
OPERATING PSI	0 - 290
LOW PRESSURE CONTROL UNIT	4 VALVE AR1314
FILTER	YES
EXTERNAL TANK LEVEL GAUGE	YES
TANK EMPTY VALVE	YES
SPRAY GUN	YES
HOSE LENGTH	48'

**MADE IN ITALY**  
**800 LITER /**  
**211 US GALLON**



SPECS	FLO-SS800NB
HP	45
CAPACITY	800 L / 211 US GAL
WEIGHT	518 LBS
PUMP	COMET BP75
OPERATING PSI	0 - 290
LOW PRESSURE CONTROL UNIT	4 VALVE AR1314
FILTER	YES
EXTERNAL TANK LEVEL GAUGE	YES
TANK EMPTY VALVE	YES
SPRAY GUN	YES
HOSE LENGTH	48'

**MADE IN ITALY**  
**26' FOLDING BOOM**



PART #	FLO-8MKIT
NOZZLE TYPE	110° FLAT FAN
# OF NOZZLES	16
BOOM LENGTH	26'

**MADE IN ITALY**  
**33' FOLDING BOOM**



PART #	FLO-10MKIT
NOZZLE TYPE	110° FLAT FAN
# OF NOZZLES	20
BOOM LENGTH	33'

**MADE IN ITALY**  
**SIDE SPRAYING BOOMS**



PART #	FLO-SSB4+4
NOZZLE TYPE	ADJUSTABLE TURBO
# OF NOZZLES	8
NOZZLE SIZE	Ø 15 1.2 CERAMIC

#### BOOM KIT CONNECTION GUIDE

PART #	FLO-4.5MHKIT	FLO-6MKIT	FLO-8MKIT	FLO-10MKIT	FLO-SSB4+4
BOOM LENGTH	15'	20'	26'	33'	
SPRAYER	FLO-SS200NB	YES	YES	YES	NO
	FLO-SS400NB	YES	YES	YES	NO
	FLO-SS600NB	YES	YES	YES	NO
	FLO-SS800NB	YES	YES	YES	YES

**MADE IN ITALY**  
**ECONOMY MIST BLOWERS**

200 LITER / 53 GALLON  
300 LITER / 79 GALLON  
400 LITER / 105 GALLON



POLYETHYLENE TANK

NYLON FAN

CAT 1, 3 POINT HITCH

COMET APS 51 PUMP

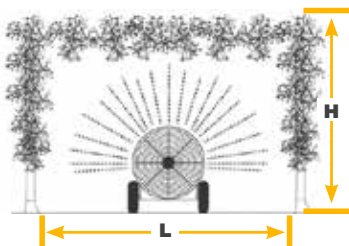

**MAX SPRAY DISTANCES (FT)**

INTER ROW	HEIGHT
11.5	8



**CONVEYOR ATTACHMENT**  
FLO-CONVEYOR



OPTIONAL

PART #	FLO-AEP200	FLO-AEP300	FLO-AEP400
WEIGHT	320 LBS	364 LBS	450 LBS
HP RATING	25 - 35 HP	25 - 50 HP	30 - 80 HP
MIN WORKING WIDTH	42"	48"	56"
CAPACITY	200 L / 53 US GAL	300 L / 79 US GAL	400 L / 105 US GAL
FAN SIZE	24"	24"	24"
DIMENSIONS	42" W X 48" D X 48" H	42" W X 50" D X 48" H	56" W X 52" D X 60" H

- 8 Single nozzles
- Maximum row spacing: 3-1/2 M
- 2-1/2 M spray height

**REPLACEMENT WEAR PARTS**

APS 51 PUMP	90.501.051	90.501.051	90.501.051
-------------	------------	------------	------------

\* ACTUAL MATERIAL VARIES BY CAPACITY

# TRAILED MIST BLOWERS

 **MADE IN ITALY**

## MIST BLOWER

600 LITER / 160 GALLON  
800 LITER / 200 GALLON  
1000 LITER / 260 GALLON

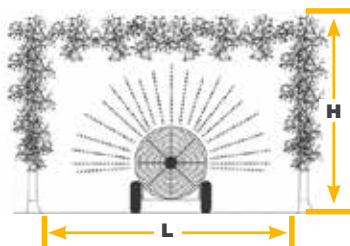
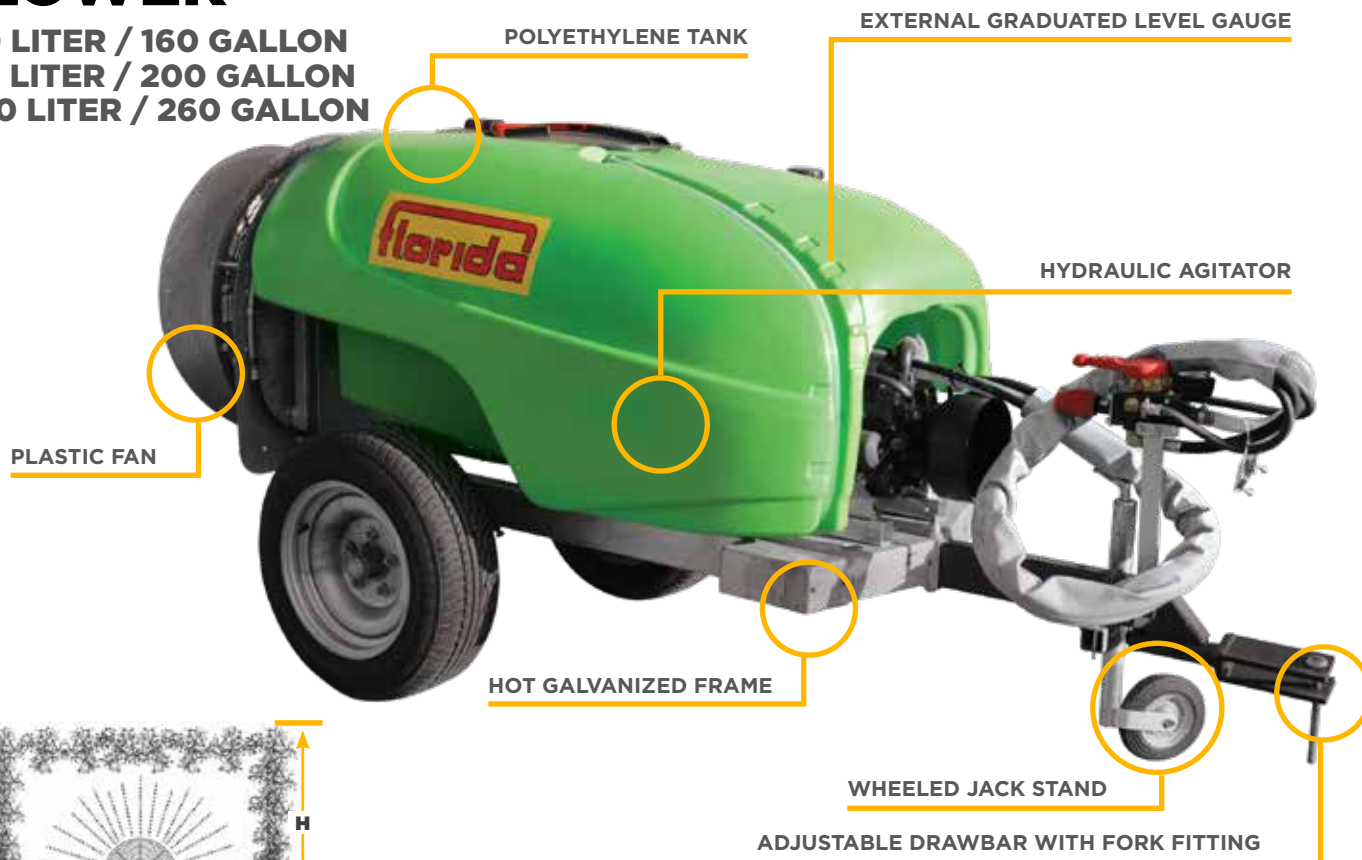

### MAX SPRAY DISTANCES (FT)

MODEL	INTER ROW	HEIGHT
FLO-PLN600EL	11.5	8
FLO-PLN800EL	11.5	8
FLO-PLN1000EL	14.75	11.5



PART #	FLO-PLN600EL	FLO-PLN800EL	FLO-PLN1000EL
WEIGHT	1,020 LBS	1,050 LBS	1,180 LBS
WIDTH	44"	48"	52"
CAPACITY	160 US GALLON	200 US GALLON	260 US GALLON
HP RATING	MIN 26 HP	MIN 30 HP	MIN 37 HP
AGITATOR	HYDRAULIC	HYDRAULIC	HYDRAULIC
PUMP	APS 96	APS 96	APS 96
FAN	28"	28"	28"

- Hand-washing tank
- APS series Comet pump
- Remote manual lever control & regulator, tractor mountable
- 2-speed gearbox with neutral
- Hydraulic agitation inside tank
- 10 brass double nozzles with spraying system D3-D5 tips
- Stainless nozzle support booms
- External suction filter with non-return valve

### REPLACEMENT WEAR PARTS

APS 96 PUMP	90.500.096	90.500.096	90.500.096
PTO	69.999.001	69.999.001	69.999.001



**MADE IN ITALY**  
**DELUXE TRAILER MIST BLOWER**

**PULL TYPE  
1000 LITER / 260 GALLON**

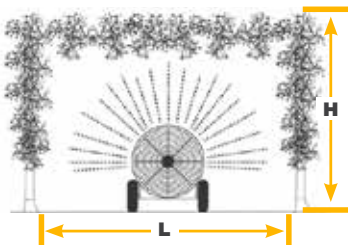
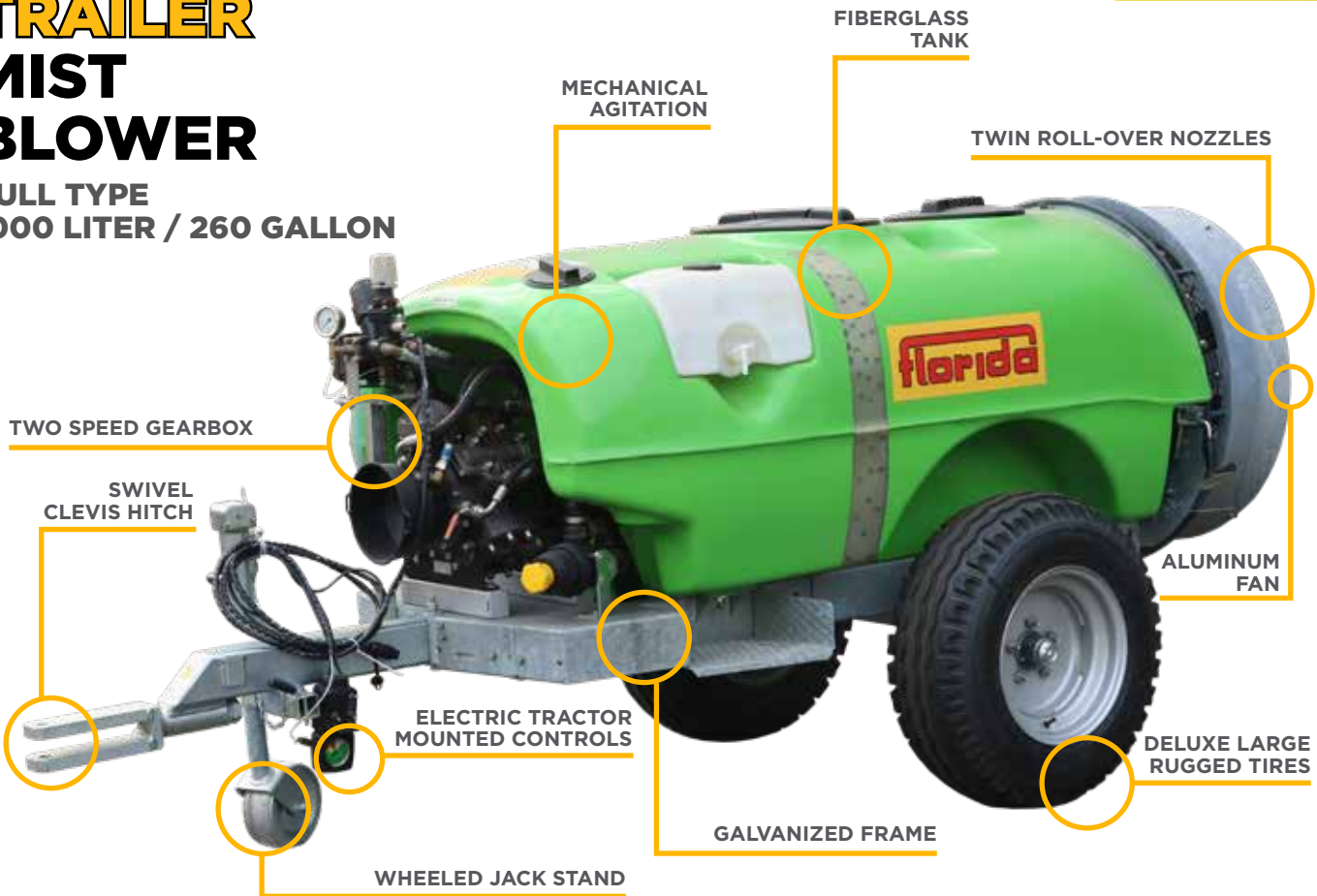

**MAX SPRAY DISTANCES (FT)**

INTER ROW	HEIGHT
14.75	11.5



**CONVEYOR ATTACHMENT  
FLO-CONVEYOR**



OPTIONAL

PART #	FLO-PLN1000MA
WEIGHT	1,200 LBS
CAPACITY	260 US GALLONS
HP RATING	MIN 37 HP
PUMP	APS 145

- Hand-washing tank
- APS series Comet pump
- 2-speed gearbox with neutral
- Hydraulic agitation inside tank
- 10 brass double nozzles with spraying system D3-D5 tips
- Stainless nozzle support booms
- External suction filter with non-return valve



**REPLACEMENT WEAR PARTS**

PTO	69.999.001
-----	------------



**CARBIDE  
TIPPED  
STUMP  
GRINDERS**

POWERED by  
**HONDA™**  
OPTIONAL  
POWER EASE ENGINE



**CARBIDE TIP**

INCLUDES  
**CARBIDE  
TIPPED**  
CUTTING  
EDGES

**15  
HP**  
POWEEASE  
ENGINE

**13  
HP**  
HONDA  
ENGINE

CUTS 9"  
BELOW  
GRADE

CUTS 10"  
ABOVE  
GRADE

PART#	BE-SGGR15	BE-SGGH13
WEIGHT	260 LBS	264 LBS
ENGINE	POWEEASE 420 CC / 15 HP	HONDA GX390 389 CC / 13 HP
CUTTING CAPACITY ABOVE GRADE	10"	10"
CUTTING CAPACITY BELOW GRADE	9"	9"
STUMP DIAMETER	NO LIMIT	NO LIMIT



**REPLACEMENT PARTS**

REPLACEMENT TEETH INCLUDES 1 EACH OF LEFT & RIGHT	101.102B.001	101.102B.001
REPLACEMENT BELTS 2 NEEDED	101.102B.002	101.102B.002

**HYDRAULIC  
3 POINT HITCH  
TRACTOR  
MOUNTED  
STUMP  
GRINDER**

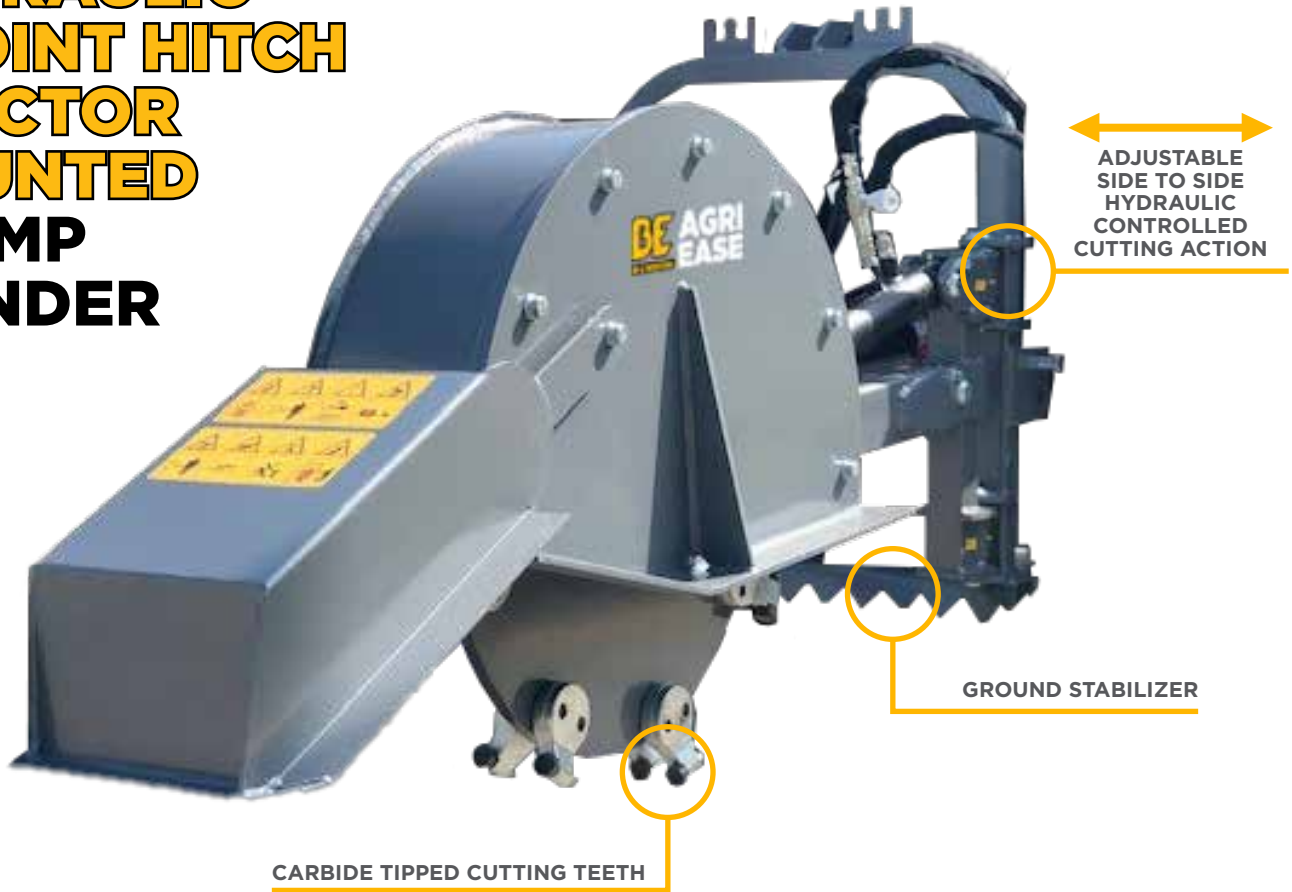

**4**  
TRACTOR  
HYDRAULIC  
PORTS  
REQUIRED

**540**  
RPM PTO

**SHEAR PIN  
PTO YOKE**

**HYDRAULIC  
POSITION  
CONTROL**

**CUTS 14"  
BELOW  
GRADE**

**CUTS 25"  
ABOVE  
GRADE**

<b>PART#</b>	BE-SGH24
<b>WEIGHT</b>	618 LBS
<b>HP RATING</b>	MIN 30 HP

**REPLACEMENT PARTS**

CUTTING TOOTH 16 NEEDED	104.101B.033
CUTTING TOOTH HOLDER 2 6 NEEDED	104.101B.034
CUTTING TOOTH HOLDER 3 6 NEEDED	104.101B.035
CUTTING TOOTH HOLDER 4 1 NEEDED	104.101B.036
CUTTING TOOTH HOLDER 5 1 NEEDED	104.101B.037
CUTTING TOOTH HOLDER 6 1 NEEDED	104.101B.038
CUTTING TOOTH HOLDER 1 1 NEEDED	104.101B.039



**3 POINT HITCH  
TRACTOR  
MOUNTED  
STUMP  
GRINDER**

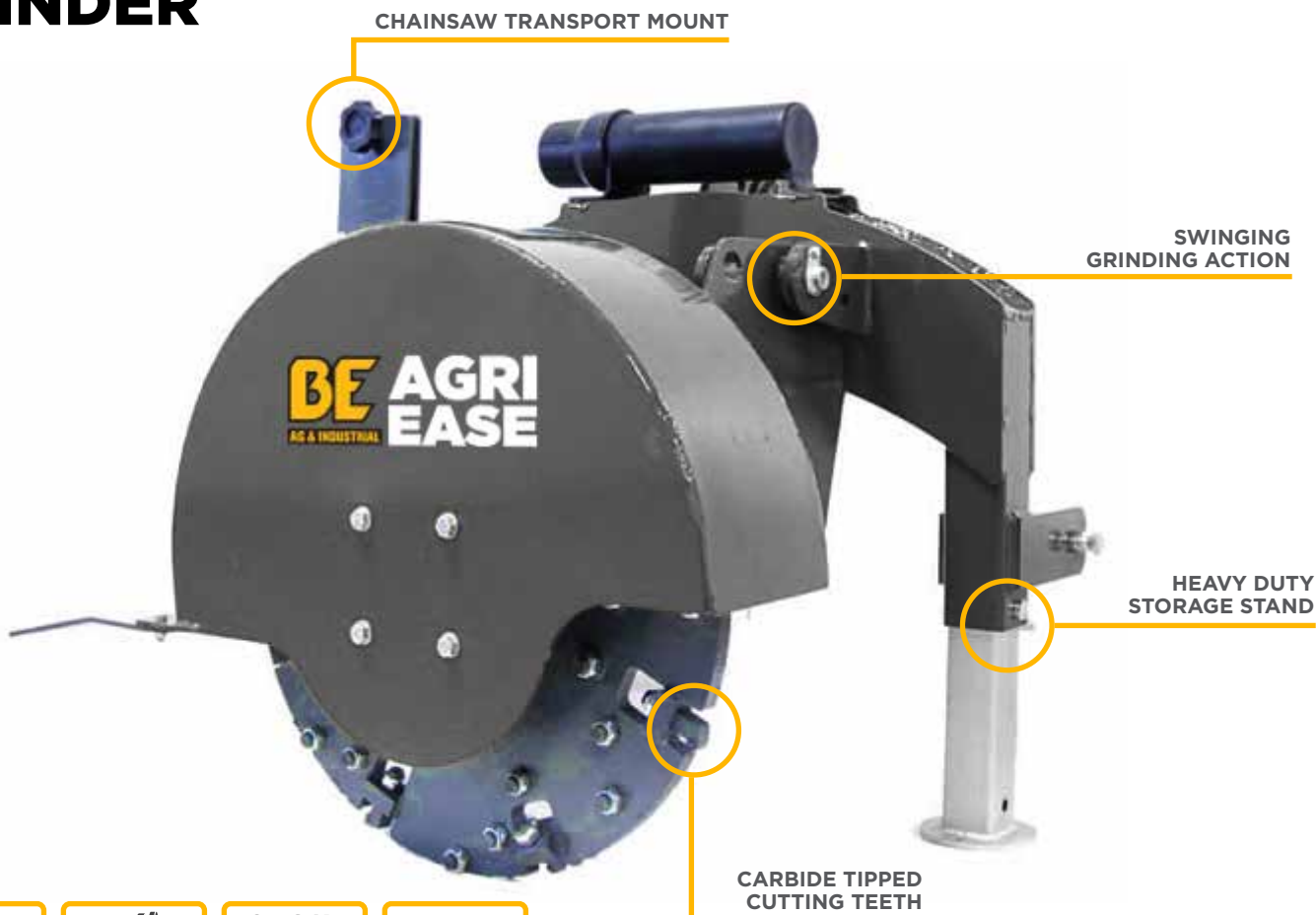

**540**  
RPM PTO

**SLIP CLUTCH**  
PTO YOKE

**CUTS 14"**  
**BELOW**  
**GRADE**

**CUTS**  
**ABOVE**  
**GRADE ARE**  
**DEPENDANT**  
**ON TRACTOR**

<b>PART#</b>	BE-SG24
<b>WEIGHT</b>	500 LBS
<b>HP RATING</b>	15-45 HP

**REPLACEMENT PARTS**

CUTTING TOOTH - 34 NEEDED	SGCUTTER
---------------------------	----------



**2-IN-1  
FLYWHEEL  
WOOD  
CHIPPER  
SHREDDER**



- 7  
HP**  
POWEREASE  
ENGINE
-   

**10" ROUGH  
TERRAIN TIRES**
- INCLUDES  
DISCHARGE  
COLLECTION  
BAG**
- 3"**  

- OPTIONAL  
VACUUM  
HOSE  
KIT**

PART #	BE-WCGF3R7
ENGINE	POWEREASE 212 CC / 7 HP
ROTOR BLADES	2
ROTOR HAMMERS	4
ROTOR DEPTH	8.5 MM
CHIPPER CAPACITY	3"
HOPPER CAPACITY	1/2"
WEIGHT	121 LBS

**REPLACEMENT PARTS**

Y HAMMER - 4 NEEDED	102.104B.052
KNIFE - 2 NEEDED	102.104B.058

**OPTIONS**

**VACUUM HOSE KIT**  
102.104B.700





**WOOD CHIPPERS**



**4" DRUM WOOD CHIPPERS**

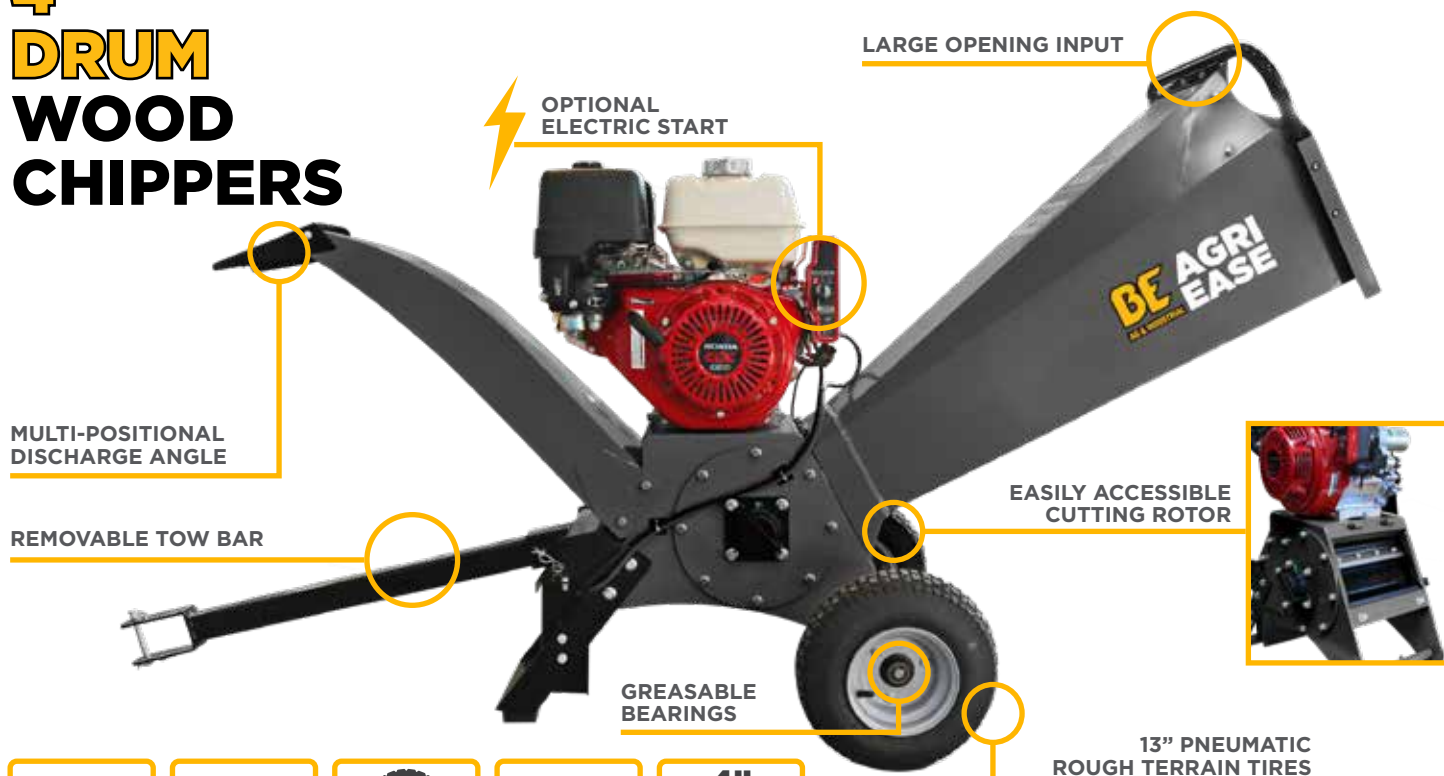

**13 HP HONDA ENGINE**

**15 HP POWEREASE ENGINE**

**13" ROUGH TERRAIN TIRES**

**INCLUDES DOCUMENT HOLDER**

**4"**

**POWERED by HONDA** **OPTIONAL POWEREASE ENGINE**

PART #	BE-WCGR4R13	BE-WCGR4R13E	BE-WCGR4H13	BE-WCGR4H13E
ENGINE	POWEREASE 420 CC / 15 HP	POWEREASE 420 CC / 15 HP	HONDA GX390 389 CC / 13 HP	HONDA GX390 389 CC / 13 HP
ROTOR BLADES	2	2	2	2
ROTOR DIAMETER	220 MM	220 MM	220 MM	220 MM
ROTOR LENGTH	240 MM	240 MM	240 MM	240 MM
STARTER TYPE	RECOIL	ELECTRIC	RECOIL	ELECTRIC
CHIPPER CAPACITY	4"	4"	4"	4"
WEIGHT	258 LBS	258 LBS	258 LBS	258 LBS

**REPLACEMENT PARTS**

FLYWHEEL KNIVES 2 NEEDED	102.106B.130	102.106B.130	102.106B.130	102.106B.130
BELT - 2 NEEDED	102.106B.107	102.106B.107	102.106B.107	102.106B.107



**WOOD CHIPPERS**

**4" FLYWHEEL WOOD CHIPPER SHREDDERS**



- 13 HP**  
HONDA ENGINE
- 15 HP**  
POWEREASE ENGINE
-   
16" ROAD READY TIRES
-   
INCLUDES DOCUMENT HOLDER
-   
2" BALL COUPLER
- 4"**  

POWERED by **HONDA**™ OPTIONAL POWEREASE ENGINE

PART #	BE-WCGF4R13	BE-WCGF4H13
ENGINE	POWEREASE 420 CC / 15 HP	HONDA GX390 389 CC / 13 HP
FLYWHEEL BLADES	2	2
STATIONARY BLADES	1	1
BELTS	2	2
STARTER TYPE	ELECTRIC	ELECTRIC
CHIPPER CAPACITY	4"	4"
WEIGHT	573 LBS	573 LBS



**REPLACEMENT KNIVES**

FLYWHEEL KNIVES - 2 NEEDED	101.101B.002	101.101B.002
STATIONARY KNIFE - 1 NEEDED	101.101B.001	101.101B.001
BELT - 2 NEEDED	101.101B.003	101.101B.003

**WOOD CHIPPER**

**4" 3 POINT HITCH TRACTOR MOUNTED FLYWHEEL WOOD CHIPPER**



<b>PART #</b>	BE-WC42G
HP RATING	18 - 45 HP
CHIPPER CAPACITY	4"
FEED	GRAVITY
ROTOR	25-1/2" DIAMETER
WEIGHT	432 LBS

**REPLACEMENT PARTS**

FLYWHEEL KNIVES - 4 NEEDED	WCKNIFE
STATIONARY KNIFE - 1 NEEDED	WC46G



**WOOD CHIPPER**



**5" 3 POINT HITCH  
TRACTOR  
MOUNTED  
FLYWHEEL  
WOOD  
CHIPPER**



PART #	BE-WCX5
HP RATING	18 - 45 HP
PTO RPM	540 - 1000 R/MIN
DIMENSIONS (LXWXH)	43" X 55" X 66"
ROTOR KNIVES	4
ROTOR SIZE	24-3/4"
ROTOR WEIGHT	125 LBS
CHIPPER CAPACITY	5"
CHIPPER HOUSING OPENING	5" X 10"
DISCHARGE HOOD ROTATION	270°
DISCHARGE HOOD HEIGHT	60"
WEIGHT	485 LBS



**REPLACEMENT PARTS**

FLYWHEEL KNIVES - 4 NEEDED	WCX5-0101
STATIONARY KNIFE - 1 NEEDED	WCX5-0102

**WOOD CHIPPER**

**6" 3 POINT  
HITCH  
TRACTOR  
MOUNTED  
FLYWHEEL  
WOOD  
CHIPPER**



<b>PART #</b>	BE-WC62G
HP RATING	30 - 100 HP
CHIPPER CAPACITY	6"
FEED	GRAVITY
ROTOR	30" DIAMETER
WEIGHT	1067 LBS

**REPLACEMENT PARTS**

FLYWHEEL KNIVES - 4 NEEDED	1012M203
STATIONARY KNIFE - 1 NEEDED	1012M204

**5" 3 POINT HITCH  
TRACTOR MOUNTED  
ROLLER-FEED  
FLYWHEEL  
WOOD  
CHIPPER**  
WITH HYDRAULIC FEED

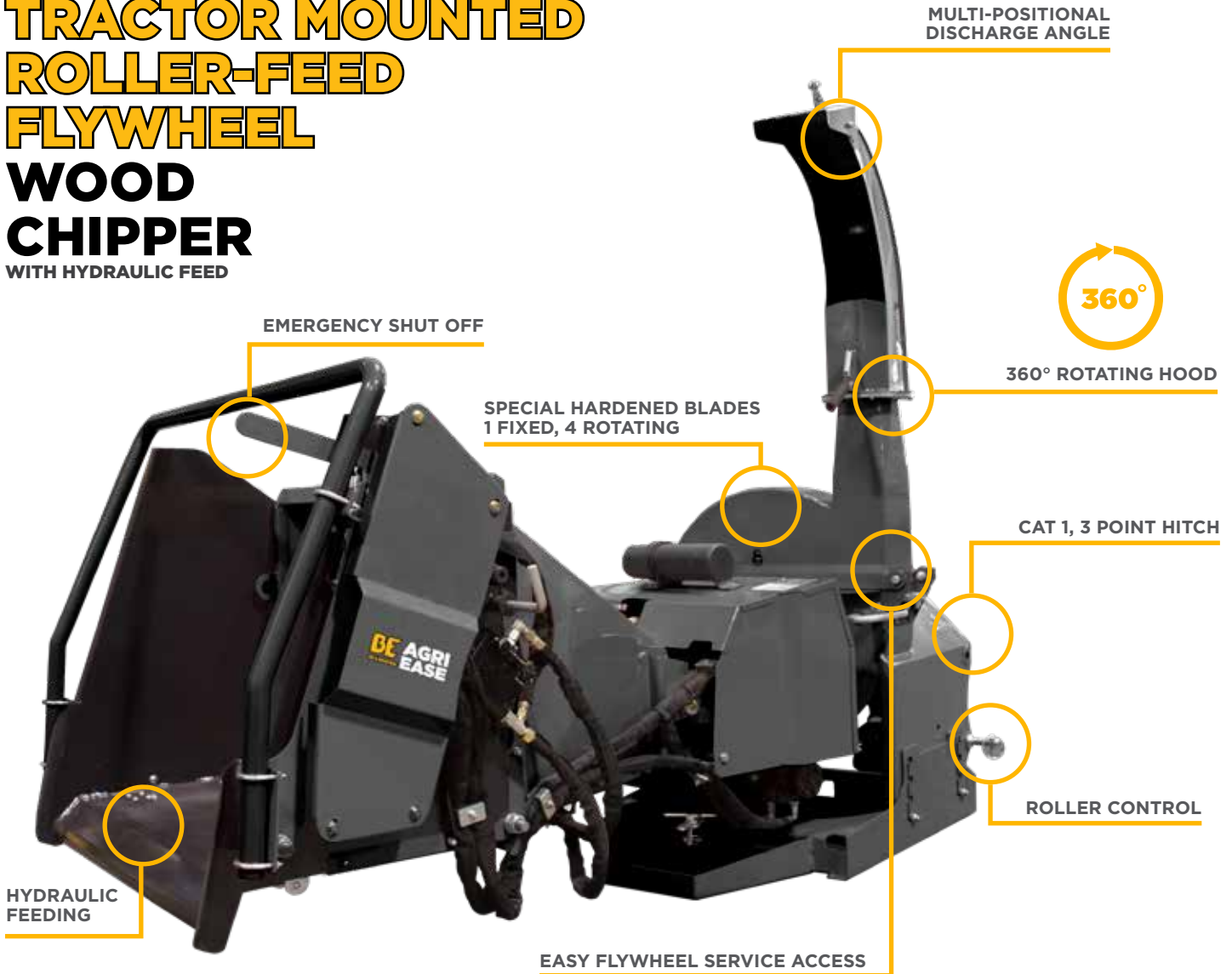

PART #	BE-WC522
HP RATING	30 - 100 HP
CHIPPER CAPACITY	5.2"
FEED	HYDRAULIC
ROTOR	25" DIAMETER
WEIGHT	860 LBS

**REPLACEMENT PARTS**

FLYWHEEL KNIVES - 4 NEEDED	704090048
STATIONARY KNIFE - 1 NEEDED	704090049



# 6 TON ELECTRIC LOG SPLITTER 110V, 60HZ



**OPTIONS**

**4 WAY CROSS WEDGE**  
LS4CWE



PART#	LS6TE
POWER OUTPUT	1300W
RATED CURRENT	12A
OIL CAPACITY	3.8 LITERS
CYCLE TIME	14 SECOND
MAX PRESSURE	2700 PSI
CYLINDER	2.2" X 17"
AUTO RETURN STANDARD VALVE TYPE	✓
*SPLITTING DIAMETER	10"
SPLITTING LENGTH	20-1/2"
SHIPPING WEIGHT	110 LBS

**REPLACEMENT WEAR PARTS**

WHEEL	330-436
HYDRAULIC VALVE	520-974
HYDRAULIC PUMP	550-203
LOG HOLDER	320-935

\* SPLITTING DIAMETER VARIES WITH TYPE OF WOOD AND ENVIRONMENTAL CONDITIONS

# 25 TON TRACTOR MOUNTED LOG SPLITTER

WITH HYDRAULIC HOSES & QD TIPS



**25 TON**  
SPLITTING  
FORCE

HORIZONTAL &  
VERTICAL  
POSITION

MINIMUM  
**6 GPM**  
REQUIRED

**2**  
TRACTOR  
HYDRAULIC  
PORTS  
REQUIRED



OPTIONS  
**4 WAY CROSS WEDGE**  
LS4CW

PART#	BE-LS25T3PT
SPLIT FORCE	25 TON
LOG LENGTH	25"
*SPLITTING DIAMETER	16"
WEDGE HEIGHT	8"
SHIPPING WEIGHT	375 LBS
OIL CAPACITY	3.25 L CYLINDER



\* SPLITTING DIAMETER VARIES WITH TYPE OF WOOD AND ENVIRONMENTAL CONDITIONS

# 25 TON LOG SPLITTERS

**HONDA™**  
GX200 6.5HP

POWERED by **HONDA™**  
OPTIONAL POWER EASE ENGINE

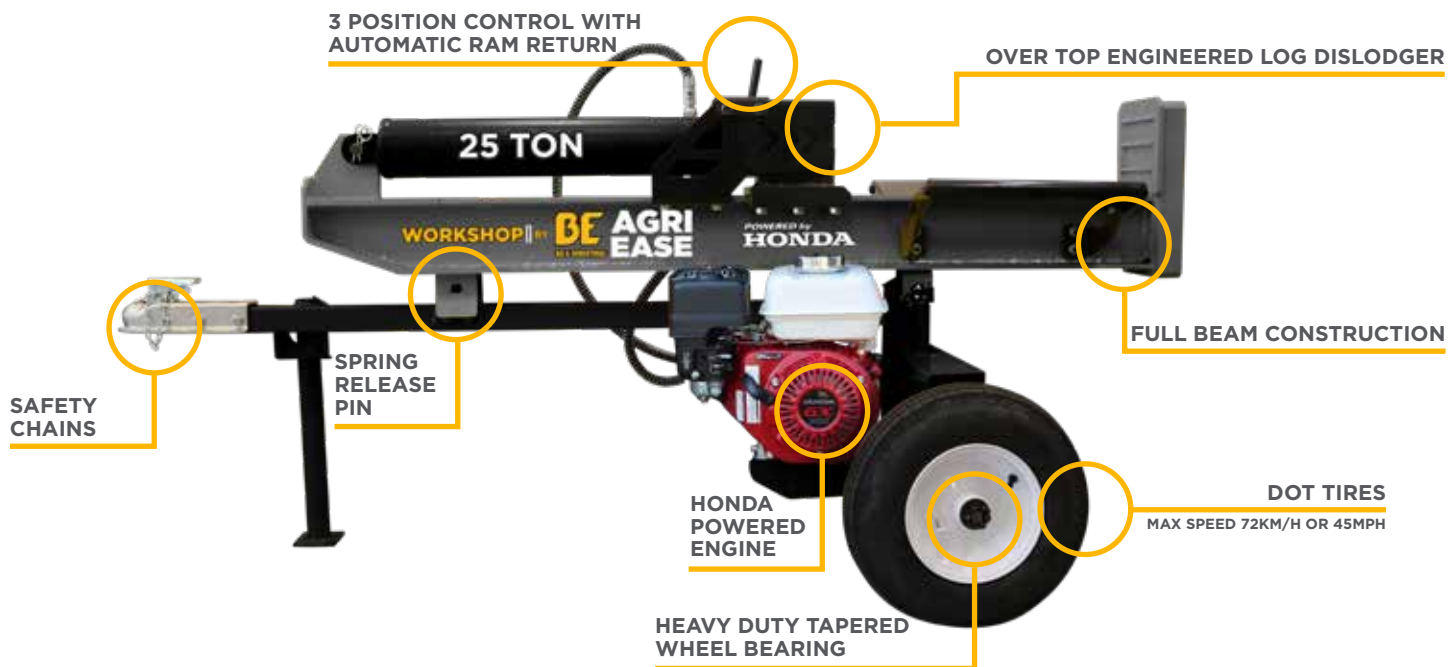

<b>25 TON</b> SPLITTING FORCE	<b>7 HP</b> POWER EASE ENGINE	<b>6.5 HP</b> HONDA ENGINE	MINOR ASSEMBLY	HORIZONTAL & VERTICAL POSITION	2" BALL COUPLER	<b>OPTIONS</b> 4 WAY CROSS WEDGE LS4CW
----------------------------------	----------------------------------	-------------------------------	----------------	--------------------------------	-----------------	---

PART #	BE-LS25ER	BE-LS25EH
SERIES	WORKSHOP	WORKSHOP
ENGINE	POWER EASE 212 CC / 7 HP	HONDA GX200 196 CC / 6.5 HP
SPLIT FORCE	25 TON	25 TON
LOG LENGTH	24"	24"
*SPLITTING DIAMETER	14"	14"
WEDGE HEIGHT	7"	7"
CYCLE TIME - FORWARD	7 SECONDS	7 SECONDS
CYCLE TIME - REVERSE	5 SECONDS	5 SECONDS
PUMP	9 GPM HI-LO	9 GPM HI-LO
MAX PRESSURE	3400 PSI	3400 PSI
CYLINDER	4" X 22"	4" X 22"
SHIPPING WEIGHT	532 LBS	532 LBS
RESERVOIR CAPACITY	12 L / 3.2 GAL	12 L / 3.2 GAL
CYLINDER CAPACITY	4.2 L / 1.1 GAL	4.2 L / 1.1 GAL

# 28 TON DELUXE LOG SPLITTERS

**HONDA™**  
GX200 6.5HP

**POWERED by HONDA™**  
OPTIONAL POWER EASE ENGINE

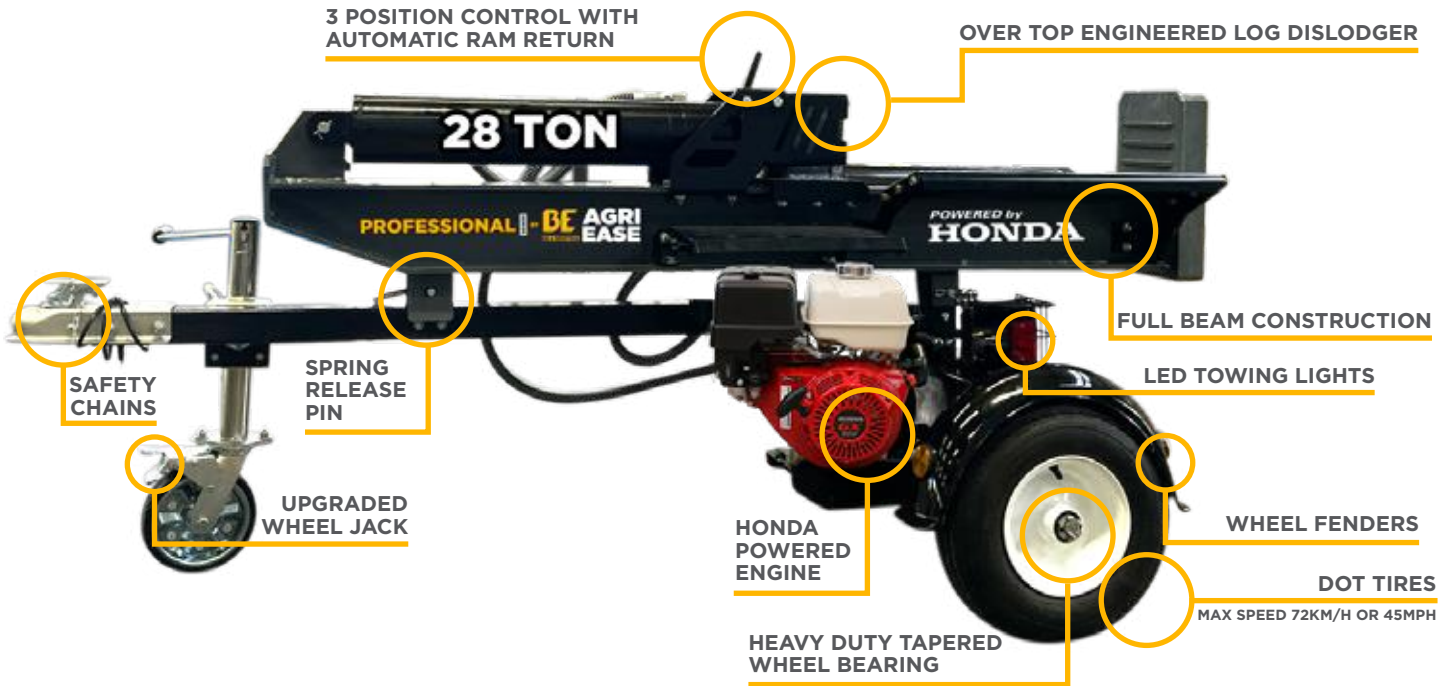

**28 TON**  
SPLITTING FORCE

**7 HP**  
POWER EASE ENGINE

**6.5 HP**  
HONDA ENGINE

MINOR ASSEMBLY

HORIZONTAL & VERTICAL POSITION

2" BALL COUPLER

**OPTIONS**  
4 WAY CROSS WEDGE LS4CW



PART #	BE-LS28DR	BE-LS28DH
SERIES	PROFESSIONAL	PROFESSIONAL
ENGINE	POWER EASE 212 CC / 7 HP	HONDA GX200 196 CC / 6.5 HP
SPLIT FORCE	28 TON	28 TON
LOG LENGTH	24"	24"
*SPLITTING DIAMETER	14"	14"
WEDGE HEIGHT	7"	7"
CYCLE TIME - FORWARD	11 SECONDS	11 SECONDS
CYCLE TIME - REVERSE	9.5 SECONDS	9.5 SECONDS
PUMP	13 GPM	13 GPM
MAX PRESSURE	3450 PSI	3450 PSI
CYLINDER	4.5" X 24"	4.5" X 24"
SHIPPING WEIGHT	624 LBS	624 LBS
RESERVOIR CAPACITY	18.9 L / 5 GAL	18.9 L / 5 GAL
CYLINDER CAPACITY	5.4 L / 1.4 GAL	5.4 L / 1.4 GAL

**LOG SPLITTERS**

**37 TON DELUXE LOG SPLITTERS**

**HONDA**  
GX270 9HP

POWERED by **HONDA**  
OPTIONAL POWEREASE ENGINE

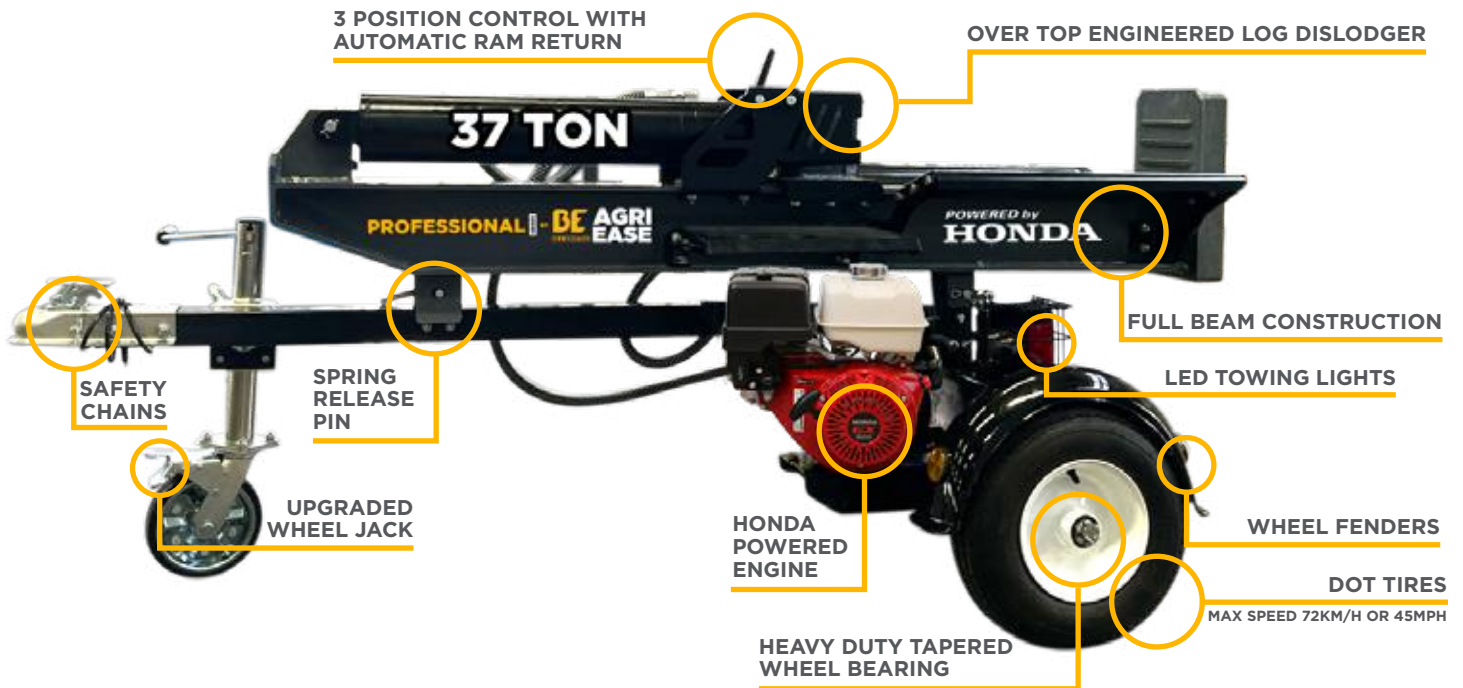

<b>37 TON</b> SPLITTING FORCE	<b>7 HP</b> POWEREASE ENGINE	<b>9 &amp; 13 HP</b> HONDA ENGINES	 MINOR ASSEMBLY	 HORIZONTAL & VERTICAL POSITION	 2" BALL COUPLER	<b>OPTIONS</b> <b>4 WAY CROSS WEDGE</b> LS4CW
----------------------------------	---------------------------------	---------------------------------------	--------------------	------------------------------------	---------------------	---

PART #	BE-LS37DR	BE-LS37DH9	BE-LS37DH
SERIES	PROFESSIONAL	PROFESSIONAL	PROFESSIONAL
ENGINE	POWEREASE 212 CC / 7 HP	HONDA GX270 270 CC / 9 HP	HONDA GX390 389 CC / 13 HP
SPLIT FORCE	37 TON	37 TON	37 TON
LOG LENGTH	24"	24"	24"
*SPLITTING DIAMETER	14"	14"	14"
WEDGE HEIGHT	7"	7"	7"
CYCLE TIME - FORWARD	11 SECONDS	11 SECONDS	11 SECONDS
CYCLE TIME - REVERSE	9.5 SECONDS	9.5 SECONDS	9.5 SECONDS
PUMP	16 GPM	16 GPM	16 GPM
MAX PRESSURE	3500 PSI	3500 PSI	3500 PSI
CYLINDER	5" X 24"	5" X 24"	5" X 24"
SHIPPING WEIGHT			
RESERVOIR CAPACITY	20.3 L / 5.4 GAL	20.3 L / 5.4 GAL	20.3 L / 5.4 GAL
CYLINDER CAPACITY	6.4 L / 1.7 GAL	6.4 L / 1.7 GAL	6.4 L / 1.7 GAL





**40 TON**  
**LOG SPLITTER**  
**HONDA™**  
GX390 13HP

POWERED by **HONDA™**

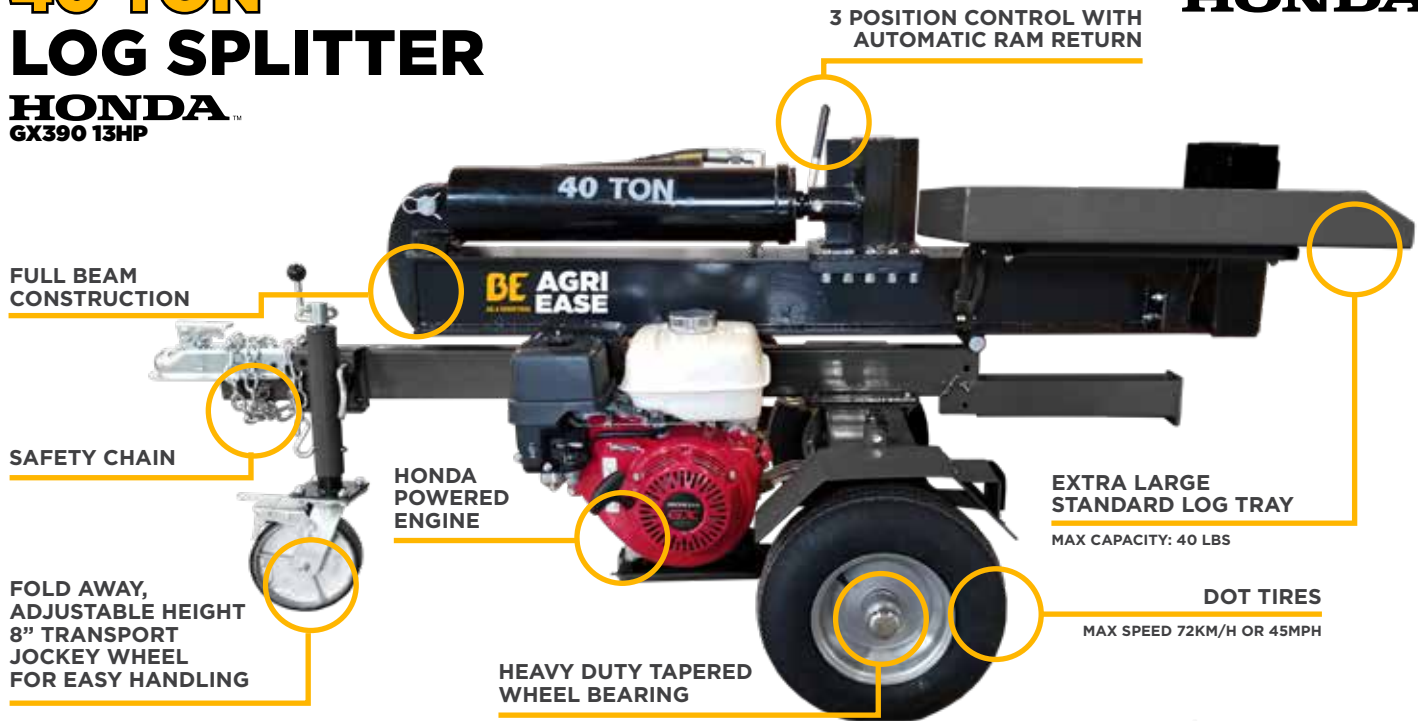

3 POSITION CONTROL WITH  
AUTOMATIC RAM RETURN

FULL BEAM  
CONSTRUCTION

SAFETY CHAIN

FOLD AWAY,  
ADJUSTABLE HEIGHT  
8" TRANSPORT  
JOCKEY WHEEL  
FOR EASY HANDLING

HONDA  
POWERED  
ENGINE

EXTRA LARGE  
STANDARD LOG TRAY  
MAX CAPACITY: 40 LBS

DOT TIRES  
MAX SPEED 72KM/H OR 45MPH

HEAVY DUTY TAPERED  
WHEEL BEARING

**40 TON**  
SPLITTING  
FORCE

**13 HP**  
HONDA  
ENGINE

INCLUDES  
OIL

HORIZONTAL  
& VERTICAL  
POSITION

2" BALL  
COUPLER

OPTIONS  
**40 TON**  
**4 WAY CROSS WEDGE**  
LS4W40

PART#	BE-LS40TS390
ENGINE	HONDA GX390 389 CC / 13 HP
SPLIT FORCE	40 TON
LOG LENGTH	21-1/2"
*SPLITTING DIAMETER	16"
WEDGE HEIGHT	8"
CYCLE TIME	18 SECONDS
PUMP	16 GPM HI-LO
MAX PRESSURE	3500 PSI
CYLINDER	5" X 20"
SHIPPING WEIGHT	664 LBS
OIL CAPACITY	16 L TANK / 6.5 L CYLINDER

\* SPLITTING DIAMETER VARIES WITH TYPE OF WOOD AND ENVIRONMENTAL CONDITIONS



# 40 TON HYDRAULIC LIFT LOG SPLITTER

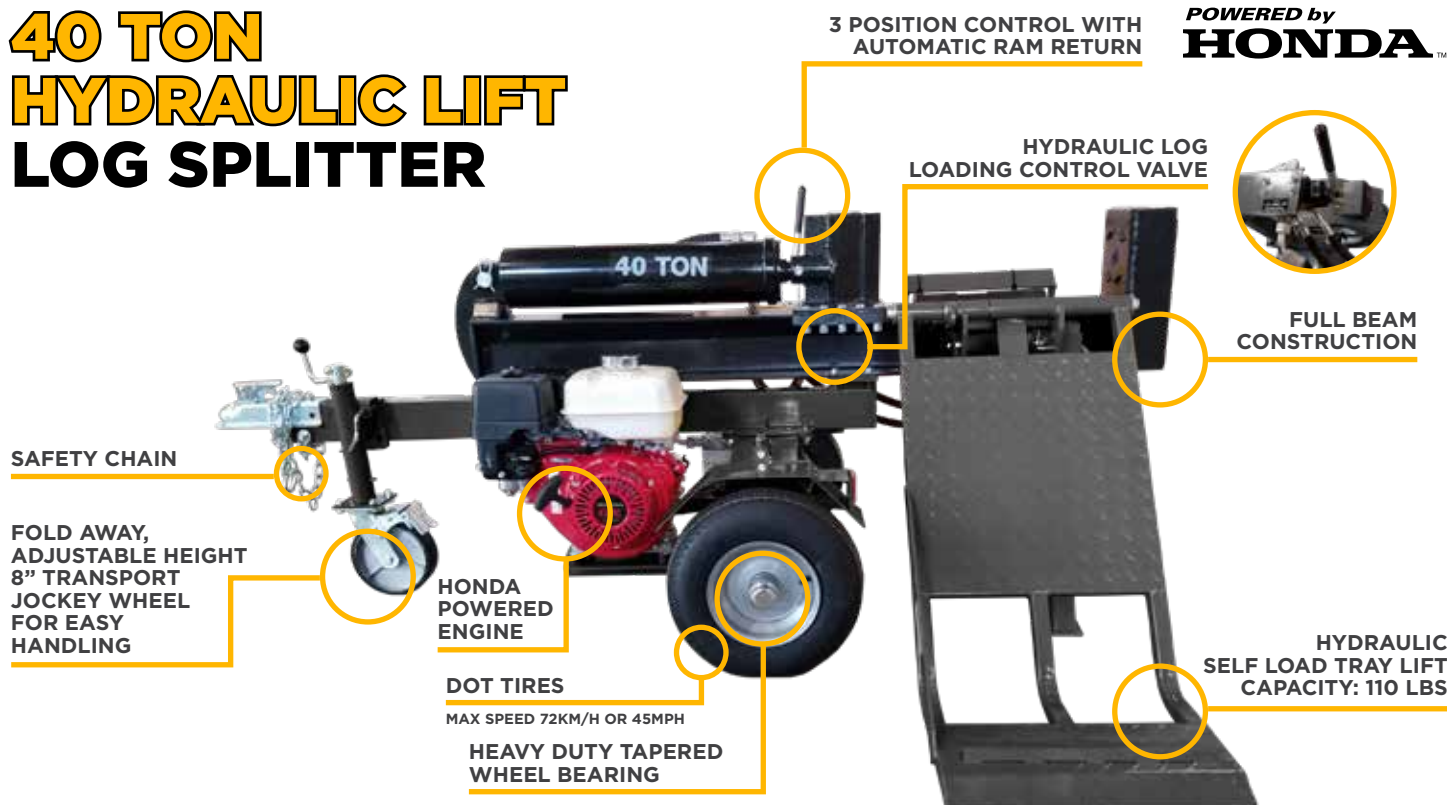

**40 TON SPLITTING FORCE**

**13 HP HONDA ENGINE**

**2" BALL COUPLER**

**SELF LOAD HYDRAULIC TRAY LIFT**

**OPTIONS**  
**40 TON 4 WAY CROSS WEDGE LS4W40**

PART#	BE-LS40TSF390
ENGINE	HONDA GX390 389 CC / 13 HP
SPLIT FORCE	40 TON
LOG LENGTH	21-1/2"
*SPLITTING DIAMETER	16"
WEDGE HEIGHT	8"
CYCLE TIME	18 SECONDS
PUMP	16 GPM HI-LO
MAX PRESSURE	3500 PSI
CYLINDER	5" X 20"
WEIGHT	700 LBS
OIL CAPACITY	16 L TANK / 6.5 L CYLINDER



\* SPLITTING DIAMETER VARIES WITH TYPE OF WOOD AND ENVIRONMENTAL CONDITIONS

# LOG SPLITTER ACCESSORIES

## LOG SPLITTER STAND



PART #	LS5TELLSTAND	
OPERATING HEIGHT	24"	
ATTACHES TO	LS5TELL	LS7TELL

## 4 WAY CROSS WEDGE

6 TON ELECTRIC



PART #	LS4CWE
ATTACHES TO	LS6TE

## 4 WAY CROSS WEDGE



PART #	LS4CW		
ATTACHES TO	BE-LS25T3PT	BE-LS25ER	BE-LS25EK
	BE-LS25EH	BE-LS28DR	BE-LS28DH
	BE-LS37DR	BE-LS37DH9	BE-LS37DH

## 4 WAY CROSS WEDGE



PART #	LS4LWEDGE-NS25T	
ATTACHES TO	BE-LS25TLE65070	BE-LS25TLEK
	BE-LS25TLE65GX	BE-LS35TLE270GX

## 4 WAY CROSS WEDGE



PART #	LS4LWEDGE-NS	
ATTACHES TO	BE-LS22TL65070	BE-LS22TLK
	BE-LS22TL65065GX	BE-LS28TEK
	BE-LS28TL65065GX	BE-LS34TL6509GX

## 4 WAY CROSS WEDGE



PART #	LS4W40	
ATTACHES TO	BE-LS40TS390	BE-LS40TSF390





# MINI CULTIVATOR TILLER

11-3/4"

SAFETY THROTTLE CONTROL

ERGONOMIC  
HANDLES

POWERFUL  
2 STROKE ENGINE

LARGE ADJUSTABLE  
TRANSPORTATION WHEELS

NARROW  
TILLING  
WIDTH

ECONOMICAL

4.25"  
MAX  
TILLING  
DEPTH

11-3/4" WIDTH



PART #	BE-MTR2
ENGINE	POWEREASE 3 HP / 52 CC
STARTER TYPE	RECOIL
FUEL CAPACITY (QTS/L)	0.85 QUARTS / 0.9 LITER
ENGINE CYCLE	2 STROKE
# OF BLADES	4
BLADE POSITION	FRONT
BLADE RPM	265
WORKING WIDTH	11-3/4"
TOTAL WIDTH	11-3/4"
TILLING DEPTH	4-1/4"
TIRE SIZE	7"
WEIGHT	32 LBS
TRANSMISSION	WORM GEAR
DRIVE SPEEDS	1 FWD

## REPLACEMENT WEAR PARTS

BLADE 1	102, 107B, 062
BLADE 2	102, 107B, 065
BLADE 3	102, 107B, 076
BLADE 4	102, 107B, 077



**FRONT  
TINE  
TILLER**

21-1/2"



UP TO  
**5.5"**  
MAX TILLING  
DEPTH

ADJUSTABLE  
TILLING  
WIDTH

21-1/2" WIDTH

PART #	BE-FTTR23
ENGINE	POWEREASE 6.5 HP / 99 CC
STARTER TYPE	RECOIL
FUEL CAPACITY (QTS/L)	1.69 QUARTS / 1.6 LITER
ENGINE CYCLE	4 STROKE
# OF BLADES	16
BLADE POSITION	FRONT
BLADE RPM	160
WORKING WIDTH	21-1/2"
TOTAL WIDTH	23-3/4"
TILLING DEPTH	5-1/2"
TIRE SIZE	8"
WEIGHT	90 LBS
TRANSMISSION	GEAR
DRIVE SPEEDS	1 FWD / 2 REV



# CENTER TINE TILLER

35-1/2"



LARGE RUGGED TERRAIN  
TRACTOR WHEELS FOR  
DITCHING EQUIPMENT



SAFETY CLUTCH CONTROL

HEIGHT ADJUSTABLE HANDLE

SIDE CONTAINMENT DISC

3 TILLING WIDTH  
CONFIGURATIONS  
35-1/2"

36" WIDTH

**UP TO  
7"  
MAX TILLING  
DEPTH**

**ADJUSTABLE  
TILLING  
WIDTH**

PART #	BE-FTTR7
ENGINE	POWEREASE 7 HP / 212 CC
STARTER TYPE	RECOIL
FUEL CAPACITY (QTS/L)	3.8 QUARTS / 3.6 LITER
ENGINE CYCLE	4 STROKE
# OF BLADES	24
BLADE POSITION	REAR
BLADE RPM	125
WORKING WIDTH	36"
TOTAL WIDTH	36"
TILLING DEPTH	7"
TIRE SIZE	15-3/4"
WEIGHT	136 LBS
TRANSMISSION	CHAIN & BELT
DRIVE SPEEDS	2 FWD / 1 REV

**OPTIONS**

**SIMPLE DITCHER**  
103.105B.700



**OPTIONS**

**ADJUSTABLE DITCHER**  
103.105B.750



**OPTIONS**

**PLOW**  
103.105B.800



**REPLACEMENT WEAR PARTS**

BLADE LH	103, 105B, 152
BLADE RH	103, 105B, 153

PART #	103.105B.700	103.105B.750	103.105B.800
--------	--------------	--------------	--------------

**REAR  
TINE  
TILLER**

26"

**★BEST  
SELLER**



ADJUSTABLE  
TILLING  
DEPTH

ROUGH  
TERRAIN  
TIRES

26" WIDTH

SAFETY  
CLUTCH  
CONTROL

5 FORWARD & 2 REVERSE  
DRIVE SPEEDS

\*PRODUCT MAY NOT BE EXACTLY AS SHOWN

PART #	BE-RTTR7
ENGINE	POWEREASE 7 HP / 212 CC
STARTER TYPE	RECOIL
FUEL CAPACITY (QTS/L)	3.4 QUARTS / 3.6 LITER
ENGINE CYCLE	4 STROKE
# OF BLADES	4
BLADE POSITION	REAR
BLADE RPM	3600
WORKING WIDTH	26"
TOTAL WIDTH	26"
TILLING DEPTH	13-3/4"
TIRE SIZE	12"
WEIGHT	155 LBS
TRANSMISSION	WORM GEAR
DRIVE SPEEDS	5 FWD / 2 REV

**REPLACEMENT WEAR PARTS**

BLADE LH	102.108C.095
BLADE RH	102.108
FORWARD BELT	102.108C.028
REVERSE BELT	102.108C.044

# BELT DRIVE REAR TINE TILLER

19"

POWERED by  
**HONDA™**  
OPTIONAL  
POWER EASE ENGINE

★**BEST  
SELLER**★

SAFETY  
CLUTCH CONTROL

2 FORWARD & 1 REVERSE  
DRIVE SPEEDS

ADJUSTABLE  
TILLING  
DEPTH

19" WIDTH



\*PRODUCT MAY NOT BE EXACTLY AS SHOWN

PART #	BE-BRTR7	BE-BRTH65
ENGINE	POWEEASE 7 HP / 212 CC	HONDA GX200 6.5 HP / 196 CC
STARTER TYPE	RECOIL	RECOIL
FUEL CAPACITY (QTS/L)	3.4 QUARTS / 3.6 LITER	3.4 QUARTS / 3.6 LITER
ENGINE CYCLE	4 STROKE	4 STROKE
# OF BLADES	4	4
BLADE POSITION	REAR	REAR
BLADE RPM	3600	3600
WORKING WIDTH	19"	19"
TOTAL WIDTH	19"	19"
MAX TILLING DEPTH	13-3/4"	13-3/4"
TIRE SIZE	12"	12"
WEIGHT	155 LBS	155 LBS
TRANSMISSION	BELT DRIVE	BELT DRIVE
DRIVE SPEEDS	2 FWD / 1 REV	2 FWD / 1 REV

## REPLACEMENT WEAR PARTS

BLADE LH	102.108C.095	102.108C.095
BLADE RH	102.108	102.108
FORWARD BELT	102.108C.028	102.108C.028
REVERSE BELT	102.108C.044	102.108C.044

# TRENCHER

18", 24"

**HONDA**  
GX200 6.5HP

POWERED by  
**HONDA**  
OPTIONAL  
POWER EASE ENGINE

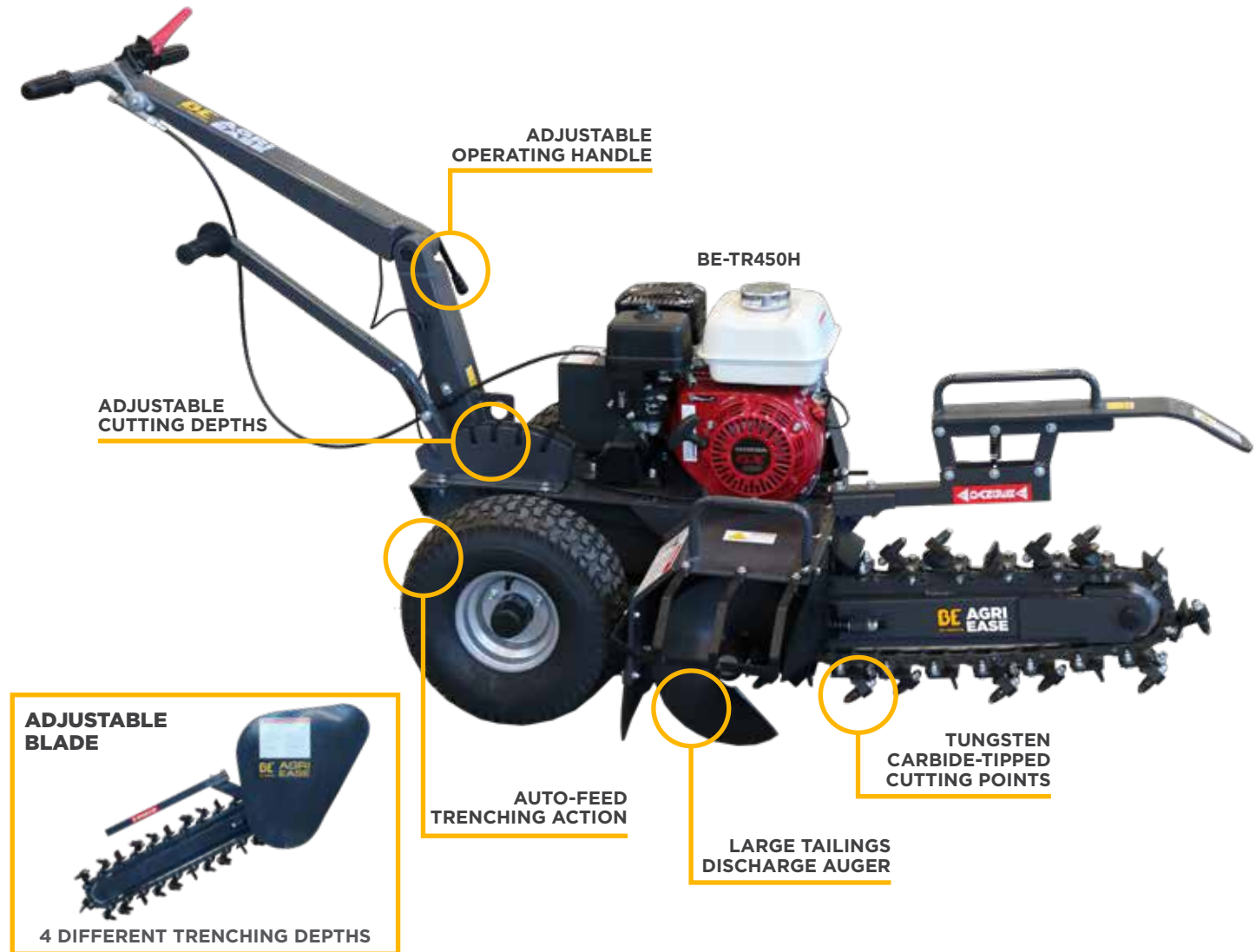

PART #	BE-TR450R	BE-TR450H	BE-TR600R	BE-TR600H
ENGINE	POWEREASE 7 HP / 212 CC	HONDA GX200 6.5 HP / 196 CC	POWEREASE 15 HP / 420 CC	HONDA GX200 13 HP / 389 CC
WEIGHT	364 LBS	364 LBS	408 LBS	408 LBS
CUTTING WIDTH	4"	4"	4"	4"
CUTTING DEPTH	6" / 10" / 14" / 18"	6" / 10" / 14" / 18"	8" / 16" / 24"	8" / 16" / 24"
TOTAL LENGTH	70"	70"	83"	83"
TOTAL WIDTH	28"	28"	29"	29"
TOTAL HEIGHT	36"	36"	44"	44"
TRENCHING SPEED	196 FT/HOUR	196 FT/HOUR	196 FT/HOUR	196 FT/HOUR
BLADES	21	21	27	27





# TRIMMER MOWER

20-1/2"

ERGONOMIC HANDLE

ADJUSTABLE HANDLE ANGLE

USES 1/8" 3 REAR SQUARE TRIMMER LINE

**IDEAL FOR HEAVY UNDERGROWTH, SLOPES, AND UNDER TREES**

LARGE RUGGED TERRAIN TIRES



**2-4"**  
CUTTING HEIGHT

**20.5"**  
WORKING WIDTH

20-1/2" WIDTH

PART #	BE-TMLR38
ENGINE	VERTICAL POWEREASE 3.3 HP / 143.5 CC
STARTER TYPE	RECOIL
FUEL CAPACITY (QTS/L)	0.76 QUARTS / 0.8 LITER
ENGINE CYCLE	4 STROKE
LINE RPM	3600
WORKING WIDTH	20-1/2"
TOTAL WIDTH	21-1/4"
CUTTING HEIGHT	2-4"
CUTTING LINE DIAMETER	1/8"
TIRE SIZE	14"
WEIGHT	82 LB

## OPTIONS

**19"**  
**TRIMMER LINE**  
20 PC PACK  
102.103B.222



**19" REPLACEMENT TRIMMER LINE**

USES 19" LONG 1/8"/3 MM SQUARE TRIMMER LINE





# HEAVY DUTY LEAF BLOWER

ERGONOMIC HANDLE DESIGN

COMPACT DESIGN FOR EASY  
MANEUVERABILITY



HIGH VOLUME 150 MPH,  
1270 CFM BLOWING FORCE

RUGGED MULTI-TERRAIN WHEELS

ADJUSTABLE FOR MAXIMUM COVERAGE



PART #	BE-LBR55
ENGINE	POWEREASE 212 CC / 7 HP
WEIGHT	112 LBS
ROTOR DEPTH	360 MM
ROTOR DEPTH	96-1/2 MM
AIR FLOW	150 MPH
AIR VOLUME	1270 CFM

**SOIL CONDITIONERS & AERATORS**

**AERATOR**

48", 60", 72"

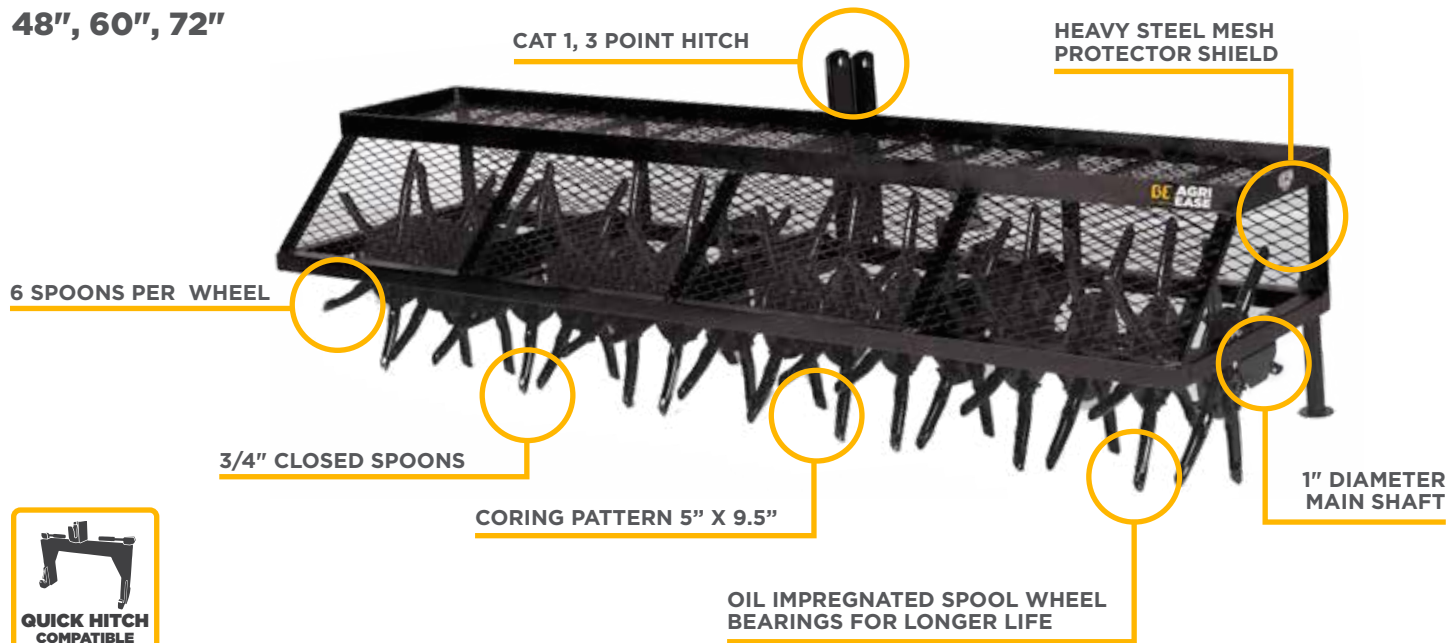

PART #	BE-AER4G	BE-AER5G	BE-AER6G
WEIGHT	370 LBS	410 LBS	450 LBS
CORING WIDTH	48"	60"	72"
HP RATING	20 HP	26 HP	34 HP
# OF SPOONS	60	72	84
# OF SPOON WHEELS	10	12	14

**FLAT  
BALLAST  
ROLLER**

59"



PART #	BE-FBR150
HP RATING	20 - 50 HP
WORKING WIDTH	59"
WEIGHT [EMPTY]	375 LBS
WEIGHT [FULL]	1411 LBS
WATER CAPACITY	105 GAL / 400 L

**OPTIONS**

ADDITIONAL SPIKE RING	BE-FBR01
-----------------------	----------

**MADE IN ITALY**  
**ORCHARD**  
**BRUSH**  
**RAKE**  
55", 67", 79"

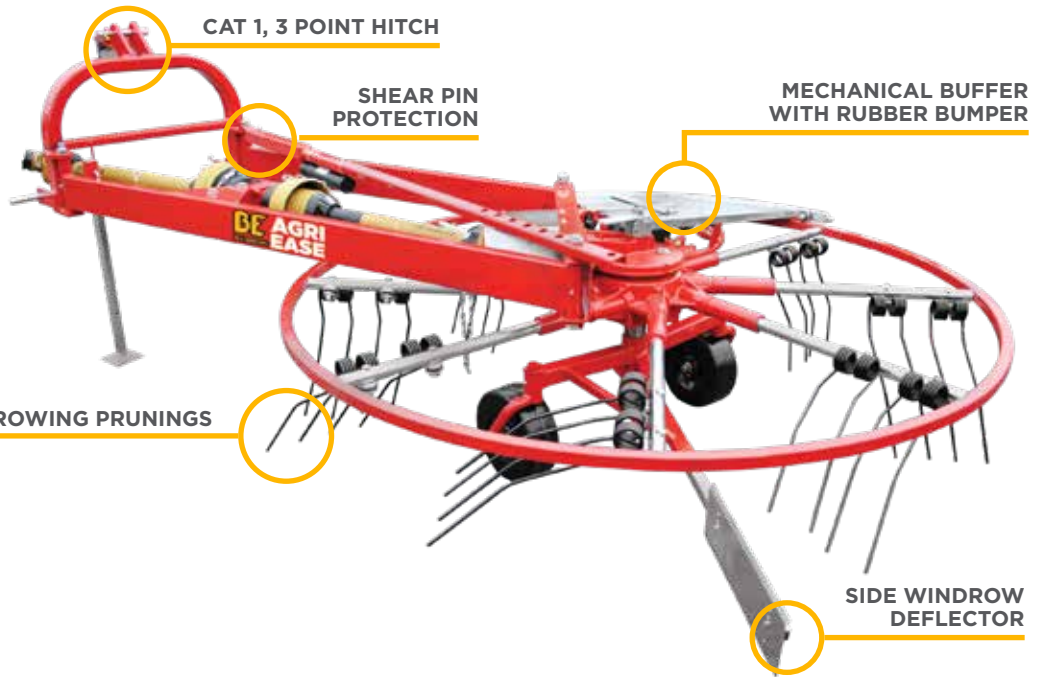

PART #	CES-RC140SP	CES-RC170SP	CES-RC200SP
WEIGHT	608 LBS	642 LBS	664 LBS
KW	21	21	21
HP RATING	28 HP	28 HP	28 HP
RAKE SWATH	55"	67"	79"

**MADE IN ITALY**  
**3 POINT**  
**HITCH**  
**POTATO**  
**LIFTER**



**OPTIONS**  
3PT OFFSET  
HITCH  
CONVERSION  
KIT  
CHM-500028

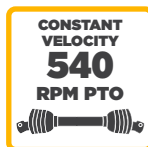

PART #	CHM-SP50
WEIGHT	353 LBS
DISCHARGE	REAR
HP RATING	18 HP
HITCH	CENTER
SIEVE BED OPENING	1.1"

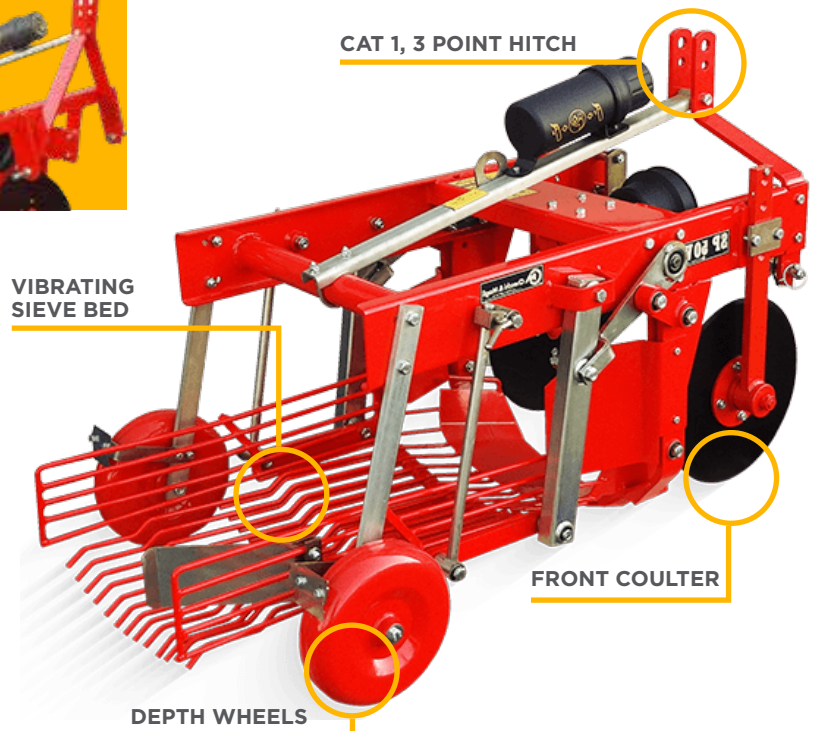



**WEIGHT BOXES, CEMENT MIXERS & BOOM POLES**

**REAR WEIGHT BOX**

3.67 FT<sup>3</sup> / 550 LB CAPACITY



**NEW!**

INCLUDES LIFT ARM PINS & TOP LINK PIN

CAT 1, QUICK HITCH COMPATIBLE



2 SLEEVES FOR HOLDING COMMON TOOLS

SLIDING DOOR FOR EASY ACCESS TO INTERIOR

2" SQUARE RECEIVER WITH 5/8" HOLE

INDUSTRIAL POWDER COATED FINISH

PART #	BE-RWB1
HITCH	CAT 1
BOX VOLUME	3.67 FT <sup>3</sup>
CAPACITY (WITH BOX)	575 LBS
CAPACITY (FILL ONLY)	550 LBS
QUICK HITCH COMPATIBLE	YES
SHIPPING WEIGHT	104 LBS
OVERALL DIMENSIONS	26-1/8" X 13-7/8" X 28-3/4"

FILL GUIDE	
FILL TYPE	WEIGHT PER FT <sup>3</sup>
CONCRETE	150 LBS
GRAVEL	110 LBS
SAND	100 LBS

**CEMENT MIXER**

5 FT<sup>3</sup> CAPACITY  
34"

17" OPENING



DOUBLE ACTING CYLINDER WITH HOSES

CAT 1, 3 POINT HITCH

PARKING SUPPORT STAND



PART #	BE-MX320G
WEIGHT	252 LBS
HP RATING	MIN 20 HP
CAPACITY	141 LITER / 37 GALLON / 0.14 M <sup>3</sup>
LENGTH	39"
WIDTH	34"
HEIGHT	39"

**BOOM POLE**

72"

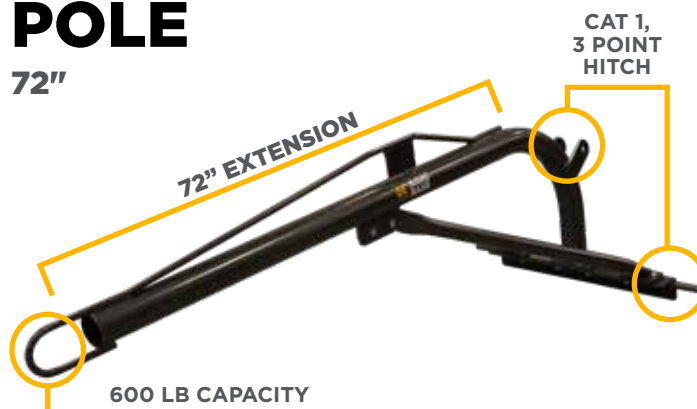

CAT 1, 3 POINT HITCH

72" EXTENSION

600 LB CAPACITY

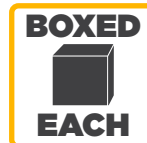

PART #	64.500.339
HITCH	CAT 1
WEIGHT	52 LBS
CAPACITY	600 LBS
LENGTH	75"
WIDTH	33"
HEIGHT	20"

# ELECTRIC POWER WHEELBARROW

5.4 FT<sup>3</sup> / 1100 LB CAPACITY

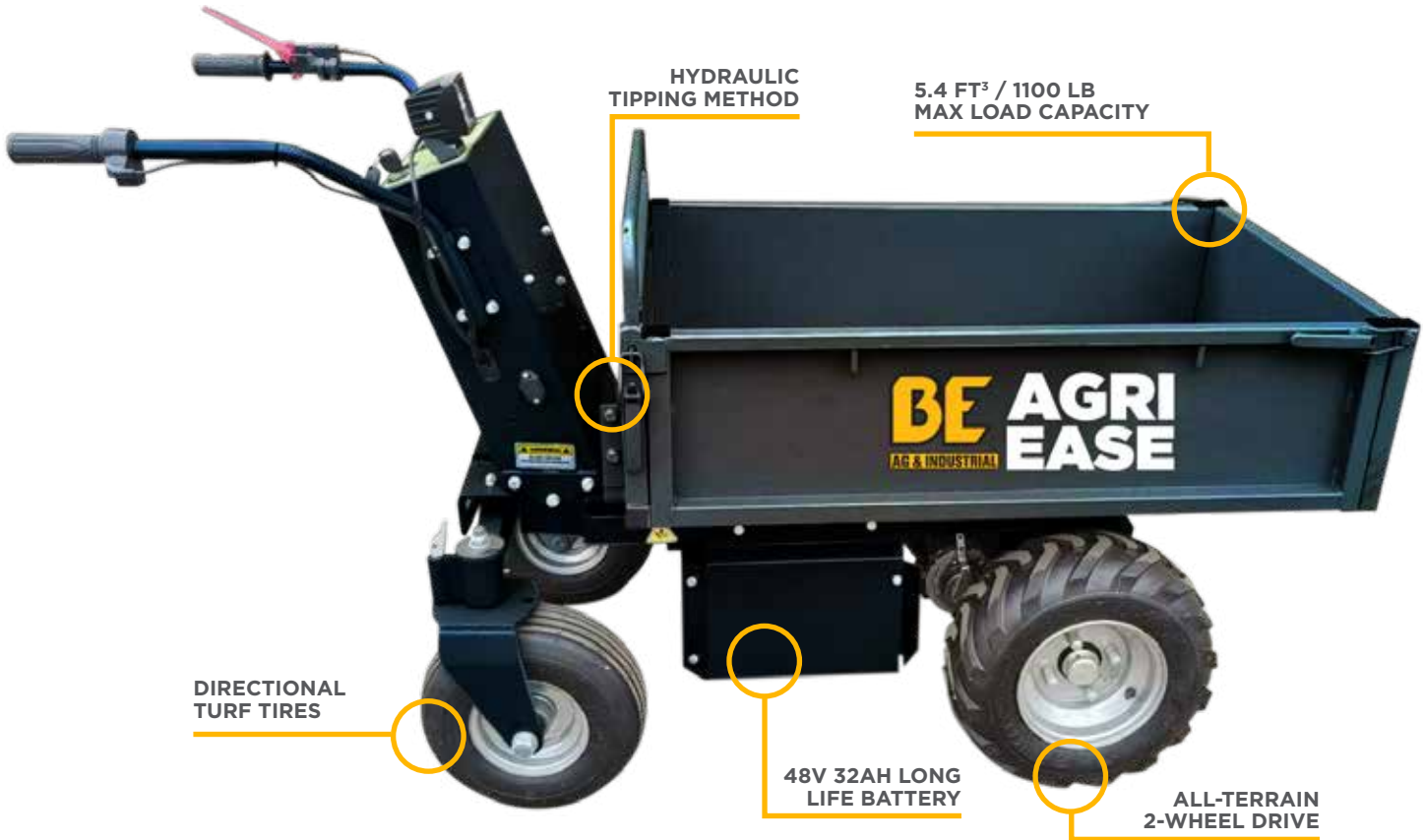

PART #	BE-MDE500
MOTOR	1000W 48V BRUSHLESS ELECTRIC
BRAKE SYSTEM	ELECTROMAGNETIC
BATTERY	48V 32AH LEAD-ACID
CHARGING CURRENT	4.5A
SPEEDS	3 FORWARD, 1 REVERSE
WORKING TIME	8 - 10 HOURS
CHARGING TIME	6 - 7 HOURS
TIRE SIZE	FRONT: 16" X 6-5/8" REAR: 13" X 5"
MAX TRAVEL SPEED	5 KM/H
TIPPING METHOD	HYDRAULIC
BUCKET DIMENSIONS	40" X 24" X 9.5"
OVERALL DIMENSIONS	69" X 29" X 42"
WEIGHT	352 LBS
SHIPPING WEIGHT	396 LBS



**POWER  
WHEELBARROW**

4.4 FT<sup>3</sup> / 660 LB CAPACITY

POWERED by  
**HONDA**<sup>™</sup>  
OPTIONAL  
POWER EASE ENGINE

**DRIVES  
LIKE A  
SKID  
STEER!**



EVENLY BALANCED  
TO MAXIMIZE CONTROL  
AND PREVENT TIPPING

4.4 FT<sup>3</sup> / 660 LB  
MAX LOAD CAPACITY

DIRECTIONAL  
AG TIRES

ALL-TERRAIN,  
ALL-WHEEL DRIVE

2-POSITION  
ENABLED CONTROLS  
WITH INSTANT STOP

**OPTIONS**

**TURF  
TREAD  
WHEEL**  
101.103C.200



PART #	BE-MD300R	BE-MD300H
ENGINE	POWEEASE 212 CC / 7 HP	HONDA GX200 196 CC / 6.5 HP
TORQUE	9.50 LB-FT	9.50 LB-FT
START TYPE	RECOIL	RECOIL
WEIGHT	350 LBS	350 LBS
SPEEDS	3 FORWARD, 1 REVERSE	3 FORWARD, 1 REVERSE
TIRE SIZE	16" X 4"	16" X 4"
ZERO TURN RADIUS	YES	YES
BELT	KEVLAR	KEVLAR
GRADE ABILITY	20°	20°
MAX TRAVEL SPEED	5 KM/H	5 KM/H
TIPPING METHOD	MANUAL	MANUAL
BUCKET DIMENSIONS	37.5" X 25.5" X 13.5"	37.5" X 25.5" X 13.5"
OVERALL DIMENSIONS	53" X 31" X 40"	53" X 31" X 40"

**METAL & POLY DUMP CARTS**



**METAL DUMP CARTS**

BLACK HAMMER TONE RUST RESISTANT FINISH

REMOVABLE TAILGATE FOR CONVENIENT LOADING & UNLOADING



**EASY ASSEMBLY**  
TAKES 15 MINUTES OR LESS.

ROUGH TERRAIN TIRES

FOOT PEDAL RELEASE SYSTEM WITH SAFETY LOCK PIN FOR EASY DUMPING

CLEVIS HITCH

STRONG AND DURABLE FRAME

**POLY DUMP CARTS**

POLY CONSTRUCTION

ROUGH TERRAIN TIRES WITH STEEL RIMS

QUICK RELEASE DUMP LATCH FOR CONVENIENT LOADING & UNLOADING

CLEVIS HITCH

TOW BAR SWIVEL, EASY TILT

ALL STEEL TUBULAR FRAME WITH POWDER COAT



**HITCH CONNECTION**  
WORKS GREAT WITH LAWN & GARDEN TRACTORS, ATVS & OTHER SMALL UTILITY VEHICLES

**POLY DUMP CARTS**

**600 LB  
CAPACITY  
POLY  
DUMP  
CART**

TCP600



**1000 LB  
CAPACITY  
POLY  
DUMP  
CART**

TCP1000



**1200 LB  
CAPACITY  
POLY  
DUMP  
CART**

TCP1200



**1200 LB  
CAPACITY  
POLY  
DUMP  
CART**

TCP12004W



**1500 LB  
CAPACITY  
POLY  
DUMP  
CART**

TCP1500



**1500 LB  
CAPACITY  
POLY  
DUMP  
CART**

TCP15004W



PART#	CAPACITY	TIRE SIZE	HEAPED LOAD SIZE	LEVEL LOAD SIZE	OVERALL DIMENSIONS	BODY DIMENSIONS
TCP600	600 LB	16"	10 FT <sup>3</sup>	7 FT <sup>3</sup>	65" X 36" X 26"	43.3" X 32.9" X 10.5"
TCP1000	1000 LB	16"	18 FT <sup>3</sup>	14 FT <sup>3</sup>	83" X 50" X 27"	58.9" X 38.0" X 15.0"
TCP1200	1200 LB	18"	19 FT <sup>3</sup>	15 FT <sup>3</sup>	85" X 47" X 31"	61.4" X 31.0" X 18.1"
TCP12004W	1200 LB	18"	19 FT <sup>3</sup>	15 FT <sup>3</sup>	85" X 50" X 31"	61.4" X 31.0" X 18.1"
TCP1500	1500 LB	18"	28 FT <sup>3</sup>	22 FT <sup>3</sup>	97" X 55" X 31"	69.1" X 39.8" X 17.9"
TCP15004W	1500 LB	18"	28 FT <sup>3</sup>	22 FT <sup>3</sup>	97" X 58" X 31"	69.1" X 39.8" X 17.9"

\* NOT DESIGNED FOR ROAD USE

**500 LB  
CAPACITY  
METAL  
DUMP  
CART**

TC5010



PART#	CAPACITY	TIRE SIZE	HEAPED LOAD SIZE	LEVEL LOAD SIZE	BODY DIMENSIONS	WEIGHT
TC5010	500 LB	16"	12 FT <sup>3</sup>	10 FT <sup>3</sup>	40.5" X 32.5" X 11.5"	83.7 LBS

\* NOT DESIGNED FOR ROAD USE

**ATV  
CLEVIS  
MOUNT  
GRADER  
BLADE**

BE-GBA5G

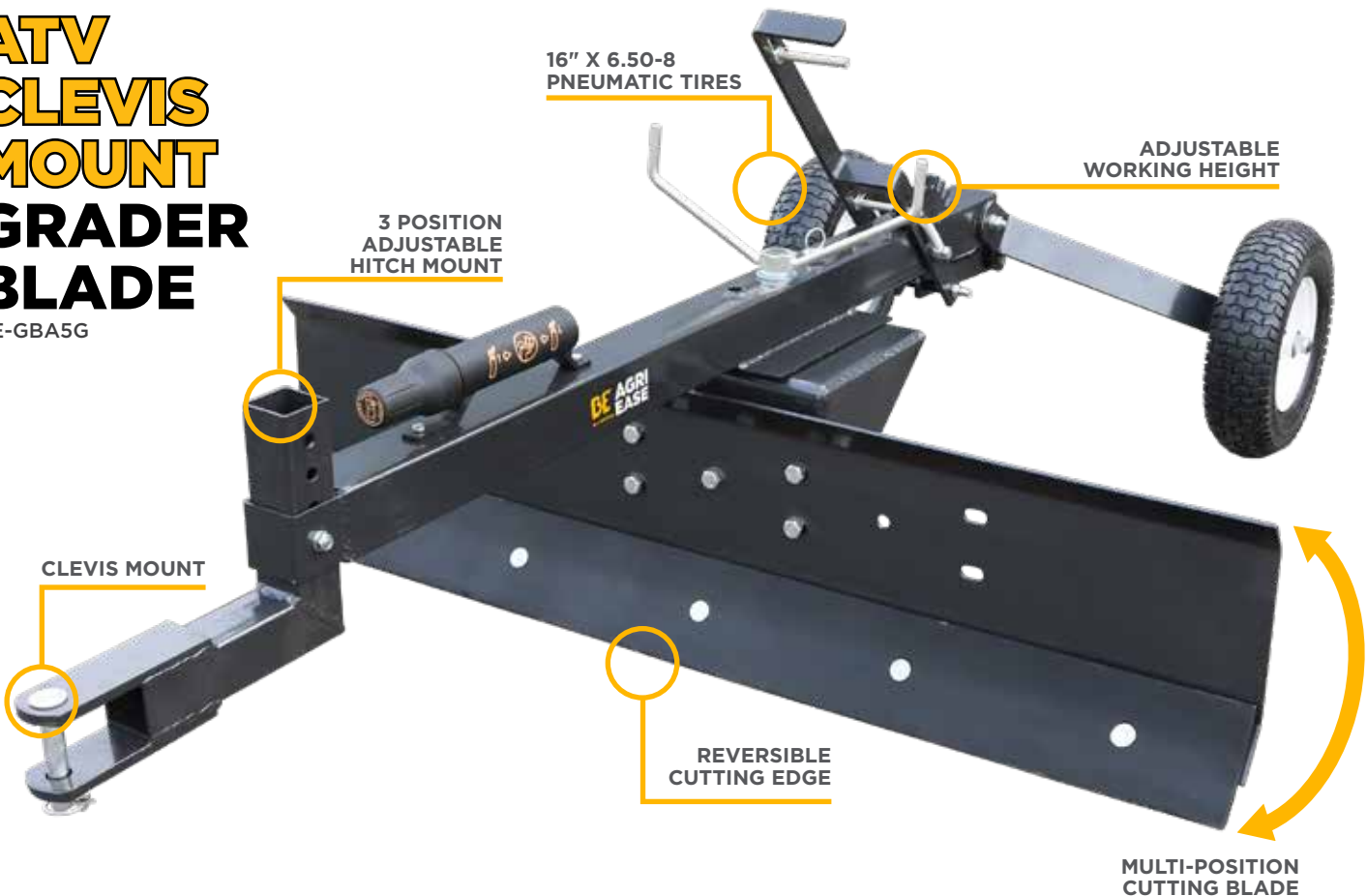



# 200 LB TRAILER DOLLY

81.200.600



# HAY BALE UTILITY DOLLY

81.000.001



**HEAVY  
DUTY  
LARGE  
CAPACITY**



# 42" LAWN CLIPPING SWEEPER

SW42T



# 40" TINE DETHATCHER

81.200.001

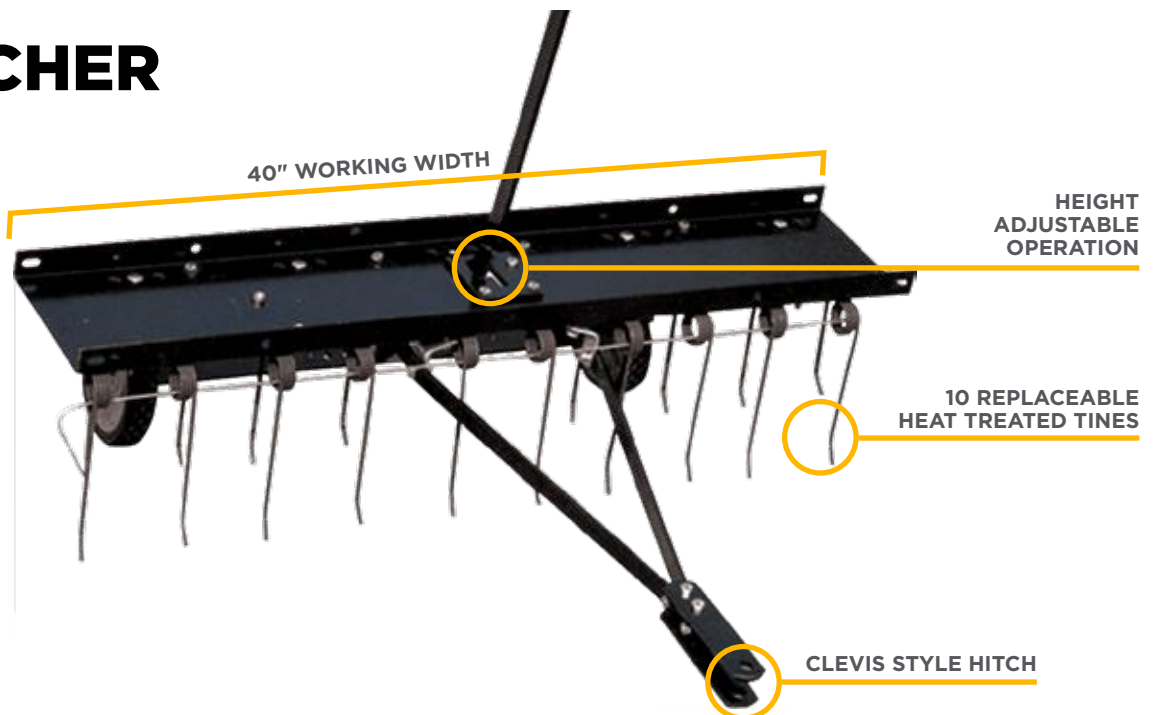

# 40" TRAILED AERATOR

81.200.004

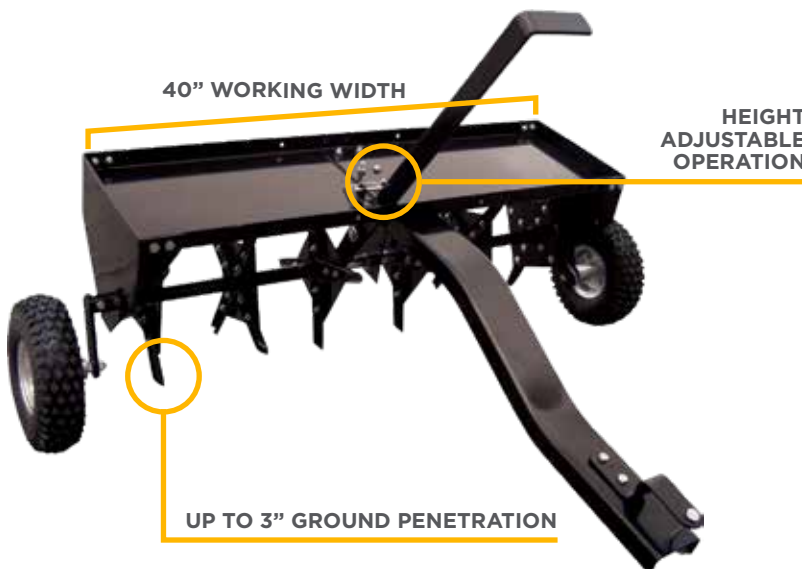

# SPIKE AERATOR DRUM

48", 60"



PART#	81.200.040	81.200.041
SIZE	48"	60"
CAPACITY	392 LB	489 LB

# FLAT BALLAST ROLLER

48", 60"



PART#	81.200.020	81.200.021
SIZE	48"	60"
CAPACITY	379 LB	467 LB

**350 LB  
ATV PULL  
FERTILIZER  
SPREADER**

MFS350T



IDEAL FOR USE WHEN A PTO IS NOT AVAILABLE  
SPREADS SEED, FERTILIZER, SAND & SALT

STEEL SQUARE HOPPER

ADJUSTABLE SPREADING COVERAGE

HEAVY DUTY CAST IRON, OIL BATH GEARBOX

ADJUSTABLE TOWBAR

14" LARGE PNEUMATIC TIRES



**250 LB  
TOWABLE  
SPREADER**

PFS105T



IDEAL FOR USE WHEN A PTO IS NOT AVAILABLE  
SPREADS SEED, FERTILIZER, SAND & SALT

14" LARGE PNEUMATIC TIRES

INCLUDES HOPPER COVER

CLEVIS HITCH



**125 LB  
WALK  
BEHIND  
SPREADER**

PFSS60P



INCLUDES SCREEN & RAIN HOPPER COVER KIT

ERGONOMIC HANDLES

INTERNAL STAINLESS STEEL FITTINGS

14" LARGE PNEUMATIC TIRES





LIMITED  
**1**  
YEAR  
WARRANTY  
★ ★ ★

**WARRANTY@BRABEREQ.COM**

**WARRANTY COVERAGE**

Braber Equipment warrants that each new product will be free of any manufacturer defects in workmanship for 1 year. This warranty applies to the original purchaser of the product and cannot be transferred. Proof of purchase must be presented when requesting warranty service.

Exceptions to this warranty include: Honda GX Engines – 3 years against manufacturer defects\*; Powerease Engines 2 years or 1000 hours, whichever comes first, against manufacturer defects; Delevan, Shurflo, and Everflo pumps to the extent of two years from date of manufacture or one year from date of invoice, whichever occurs first against manufacturer defects\*\*; Rotary Cutter Gearboxes to the extent of 6 years against manufacturer defects.

Exclusions to this warranty include, but are not limited to, misuse or negligent use of the product, expected and reasonable wear of consumable components and components included in regular maintenance. For all warranty claims please contact Braber Equipment before performing service or providing replacement components.

**FOR BRABER EQUIPMENT DEALERS**

Pre-approval for all warranty claims is required. Any warranty claim submitted without preapproval may be denied.

This warranty does not cover freight or labor charges associated with the inspection and testing of products which are found to not be a valid warranty claim.

All warranty returns require pre-approval by Braber Equipment before returning merchandise for a warranty inspection. Warranty claims without this pre-approval will not receive credit.

Freight claims or damages for products shipped by Braber Equipment must be reported within 48 hours of receipt. Orders received with missing parts need to be reported within two business days.

Hidden damage must be reported within 2 business days of first noticing and cannot be claimed on items received more than 90 days prior.

Please contact Braber Equipment for complete details.

\*Must contact local Honda Power Equipment for warranty

\*\*Delevan, Shurflo, and Everflo pumps should be on a dedicated (individual) circuit, protected by the fuse indicated on the motor label. The total current draw on the circuit must not exceed the recommended manufacturer's specifications. If the pump is used in conjunction with other components, overload current protection (fuse or circuit breaker) and wire size must be for the total amp requirement of all devices on the circuit. The pump should not be located in an area less than one cubic foot unless adequate ventilation is provided. Failure to adhere to the above will result in the unit being void of warranty.



# BE AGRI EASE

AG & INDUSTRIAL

## EQUIPMENT CATALOG

2024

### SKID STEER GRAPPLE BUCKET

BE-SSGB2242



PG. 93

### SKID STEER MOUNT SINGLE PRONG BALE SPEAR

BE-BSS39BO500G



PG. 91

### HEAVY DUTY DISC HARROW

BE-DH185FK



PG. 110

### ELECTRIC POWER WHEELBARROW

BE-MDE500



PG. 170

### CENTER TINE TILLER

BE-FTTR7



PG. 161

### 5" 3 POINT HITCH TRACTOR MOUNTED FLYWHEEL WOOD CHIPPER

BE-WCX5



PG.148

**BRABEREQ.COM**

PHONE: 604-850-7770

FAX: 604-850-7774

TOLL FREE PHONE: 1-877-588-3311

TOLL FREE FAX: 1-800-665-7334

WGSALES@BRABEREQ.COM